

CHAPTER II – *Decision making*

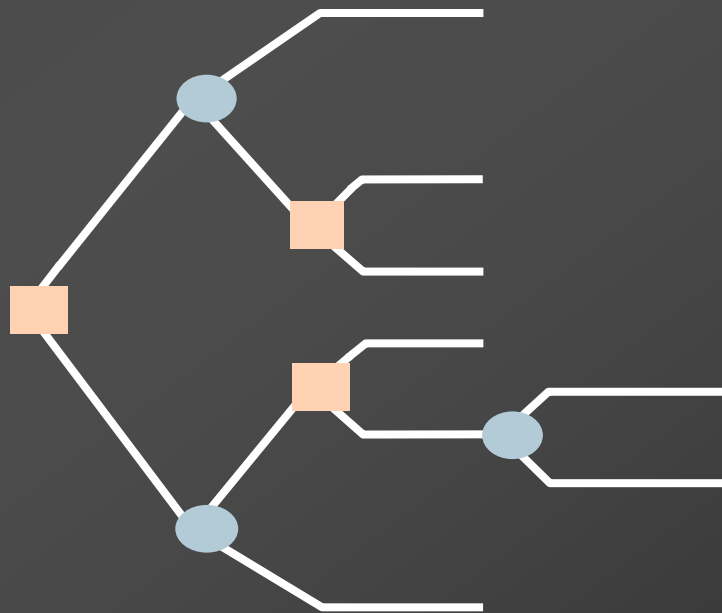

1-Break-even analysis

- *Evaluating services or products*
 - *Volume sufficient to break even*
 - *The portion of the total cost that varies directly*
 - *The variable cost per unit*

Example

FINDING THE BREAK-EVEN QUANTITY

A hospital is considering a new procedure to be offered at \$200 per patient. The fixed cost per year would be \$100,000, with total variable costs of \$100 per patient. What is the break-even quantity for this service? Use both algebraic and graphic approaches to get the answer.

Break-Even Analysis



Break-Even Analysis

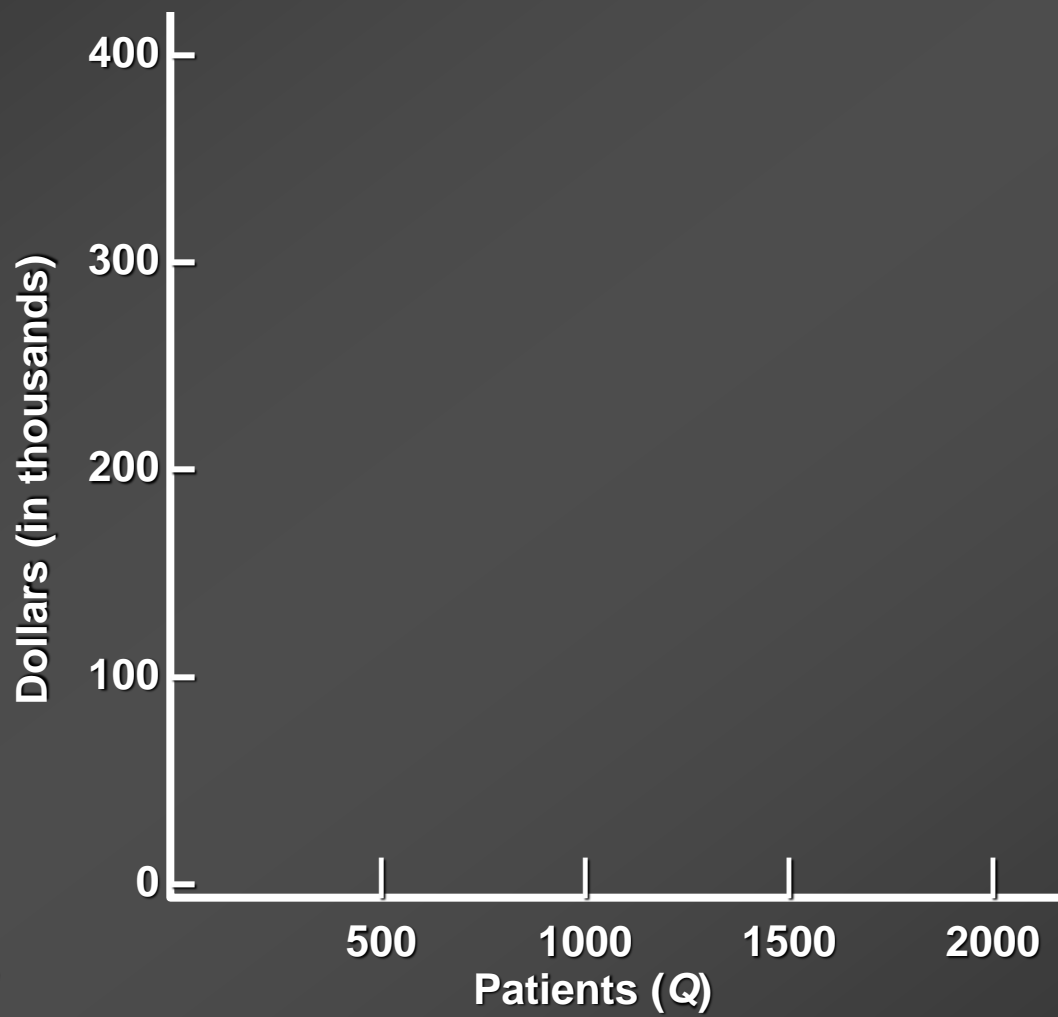

Example A.1

Break-Even Analysis



Quantity (patients) (Q)	Total Annual Cost (\$) ($100,000 + 100Q$)	Total Annual Revenue (\$) ($200Q$)
0	100,000	0
2000	300,000	400,000

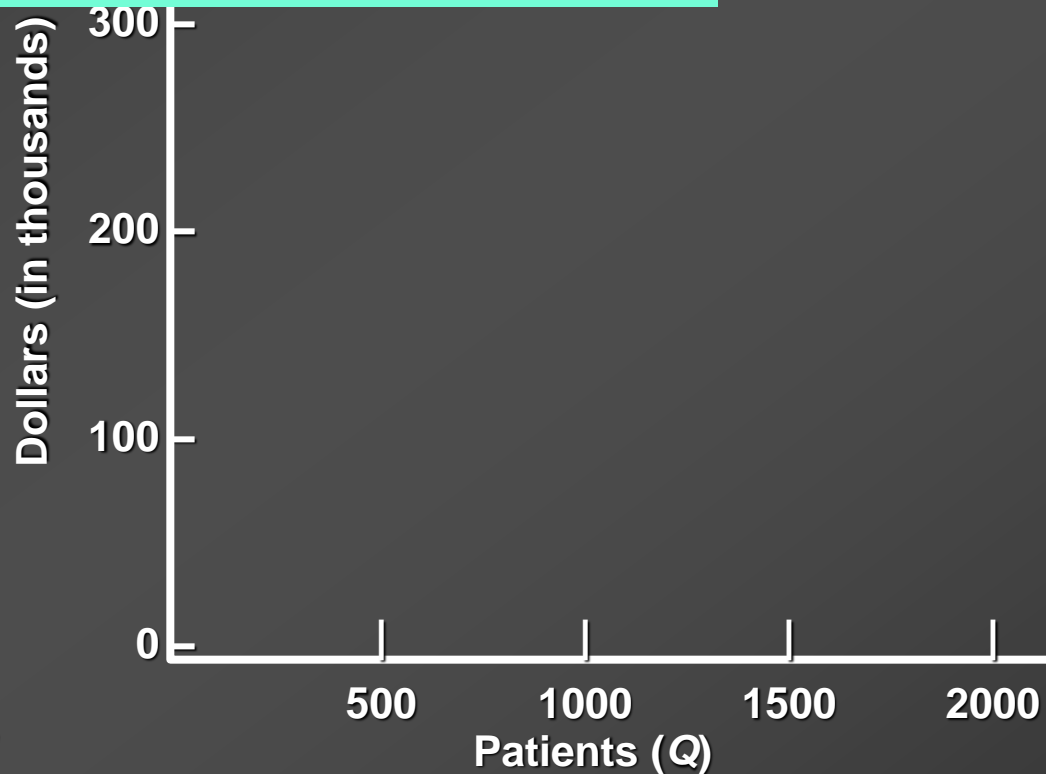

Example A.1

Break-Even Analysis



Quantity (patients) (Q)	Total Annual Cost (\$) (100,000 + 100Q)	Total Annual Revenue (\$) (200Q)
0	100,000	0
2000	300,000	400,000

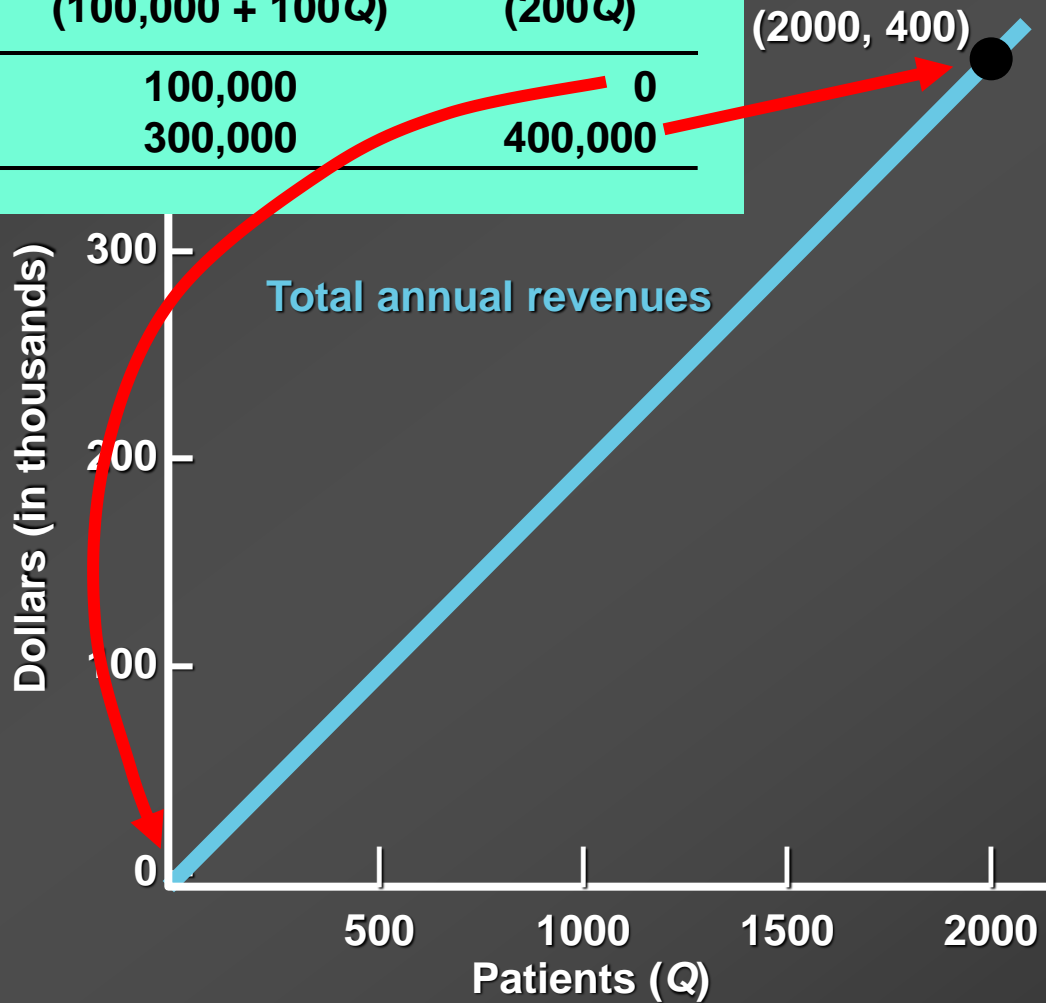

Example A.1

Break-Even Analysis



Quantity (patients) (Q)	Total Annual Cost (\$) (100,000 + 100Q)	Total Annual Revenue (\$) (200Q)
0	100,000	0
2000	300,000	400,000

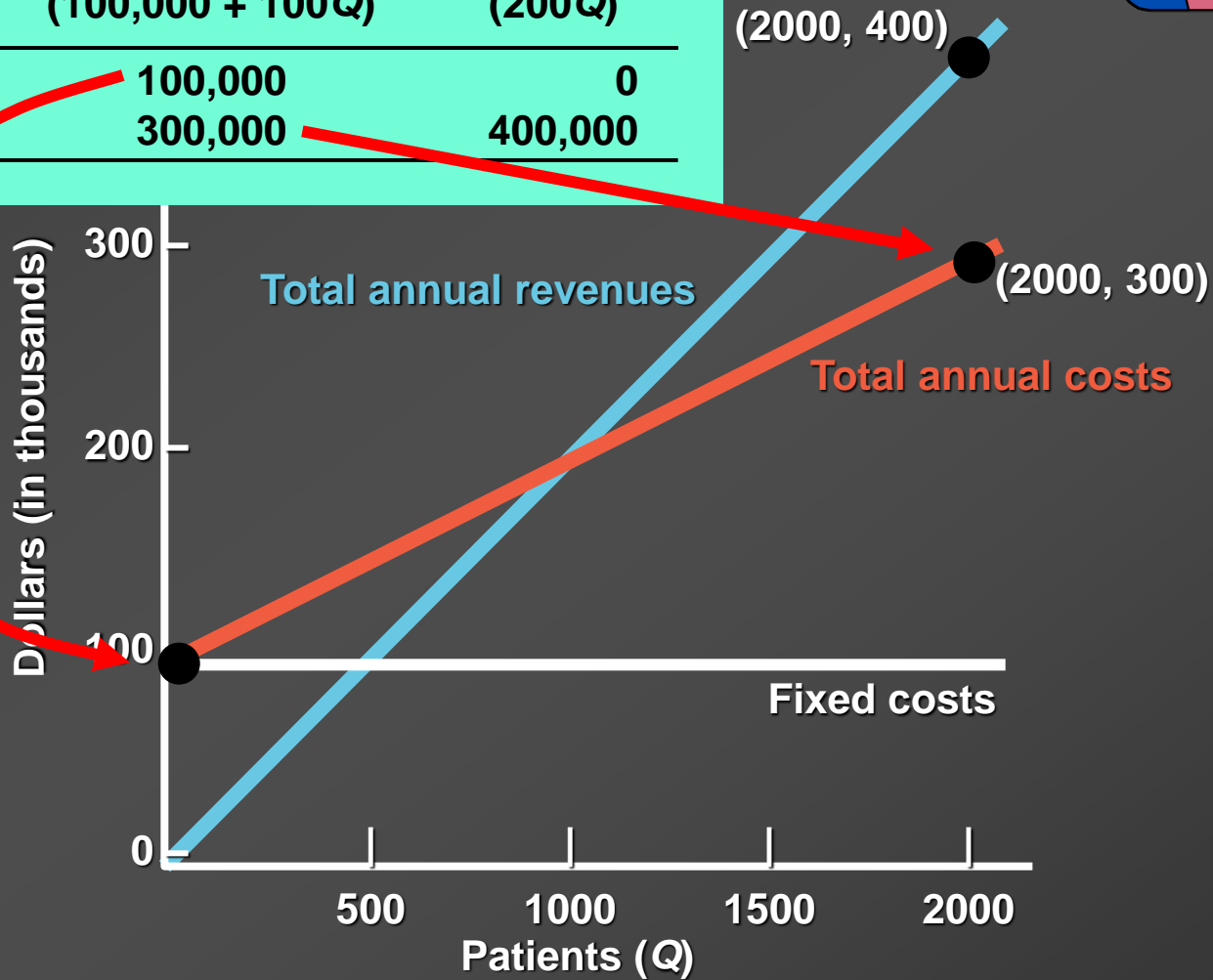

Example A.1

Break-Even Analysis



Quantity (patients) (Q)	Total Annual Cost (\$) (100,000 + 100Q)	Total Annual Revenue (\$) (200Q)
0	100,000	0
2000	300,000	400,000

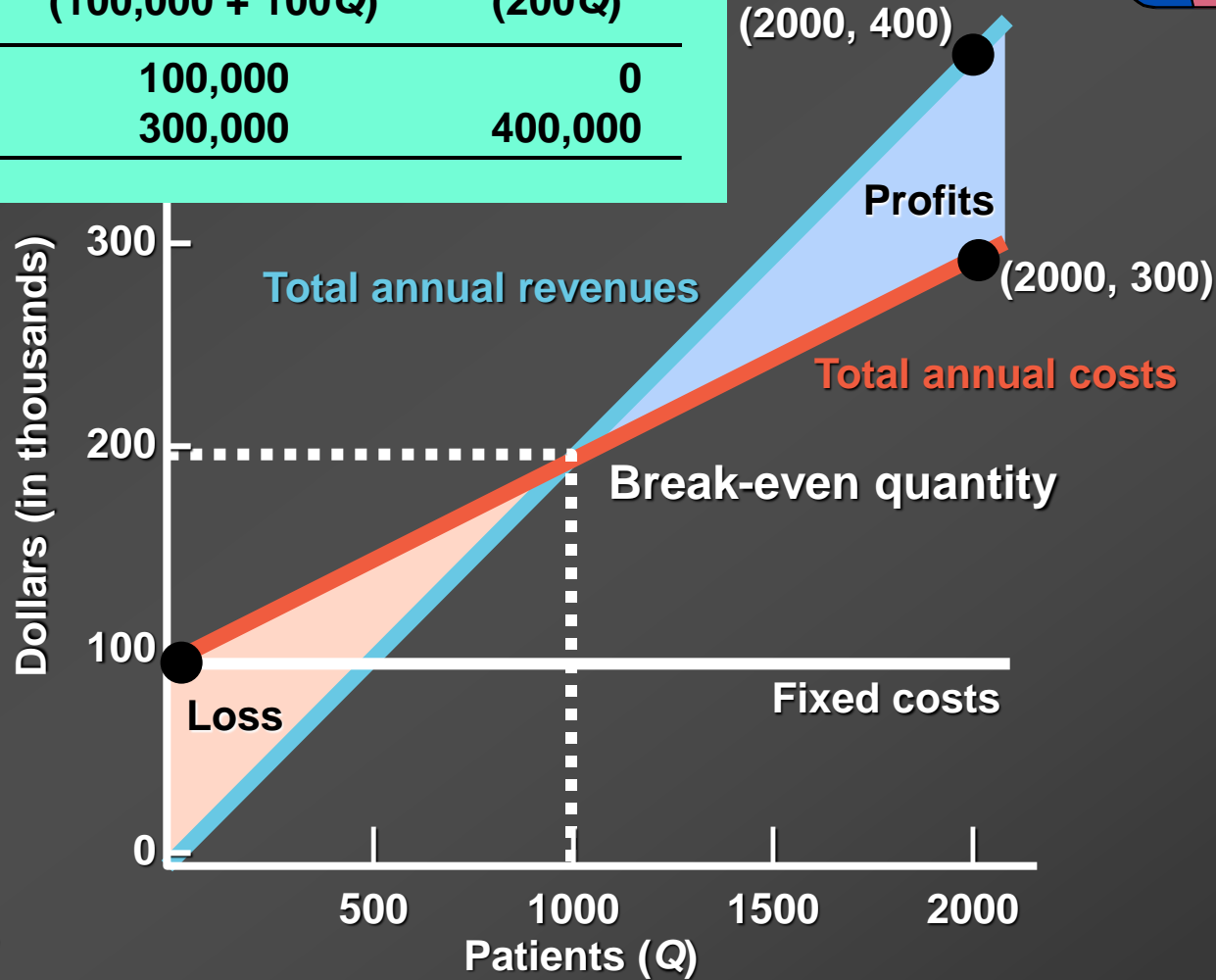

Example A.1

Break-Even Analysis

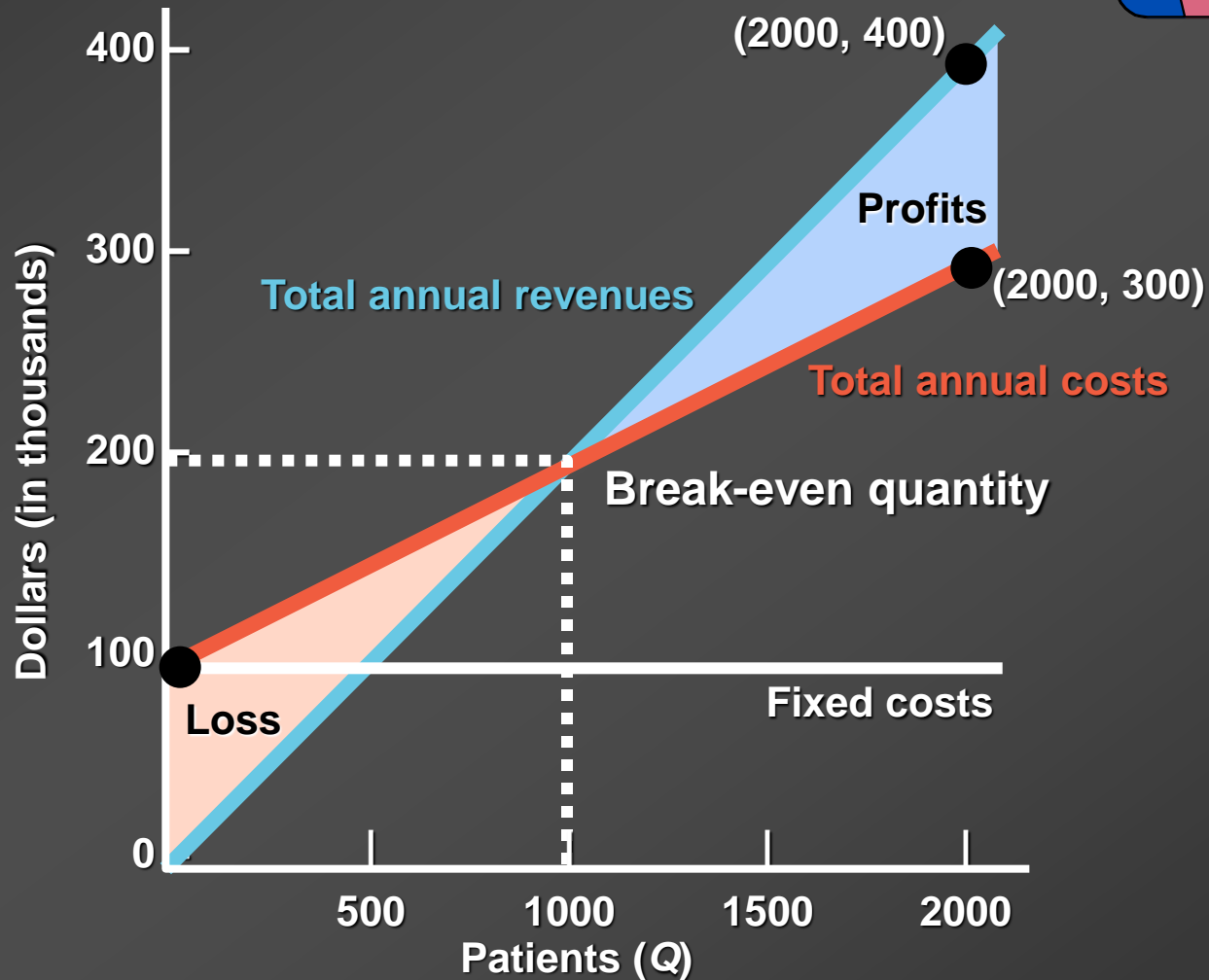
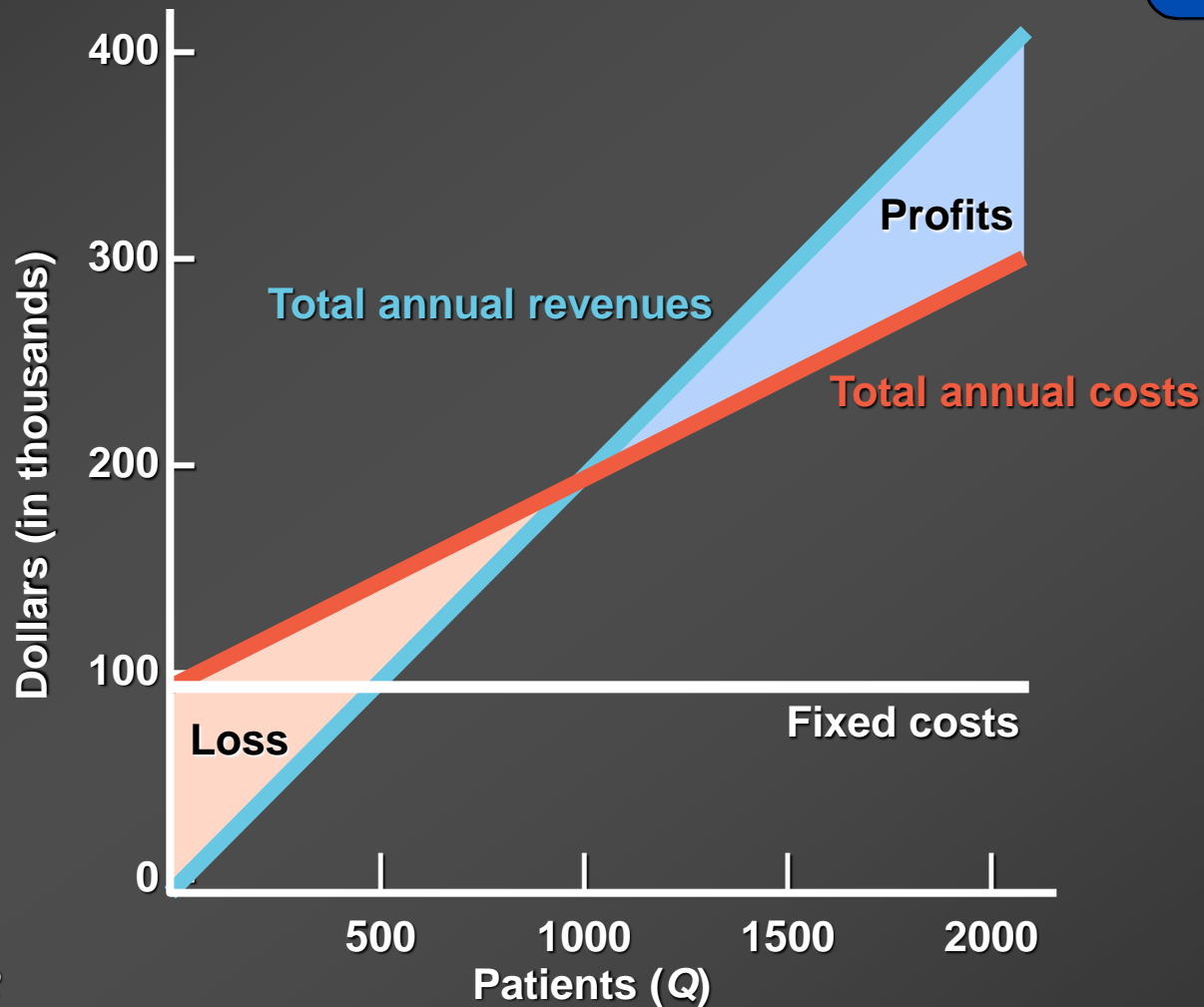

Figure A.1

Sensitivity analysis of sales forecasts

If the most pessimistic sales forecast for the proposed service in Figure A.I were 1,500 patients, what would be the procedure's total contribution to profit and overhead per year?

Sensitivity Analysis



Example A.2

Sensitivity Analysis

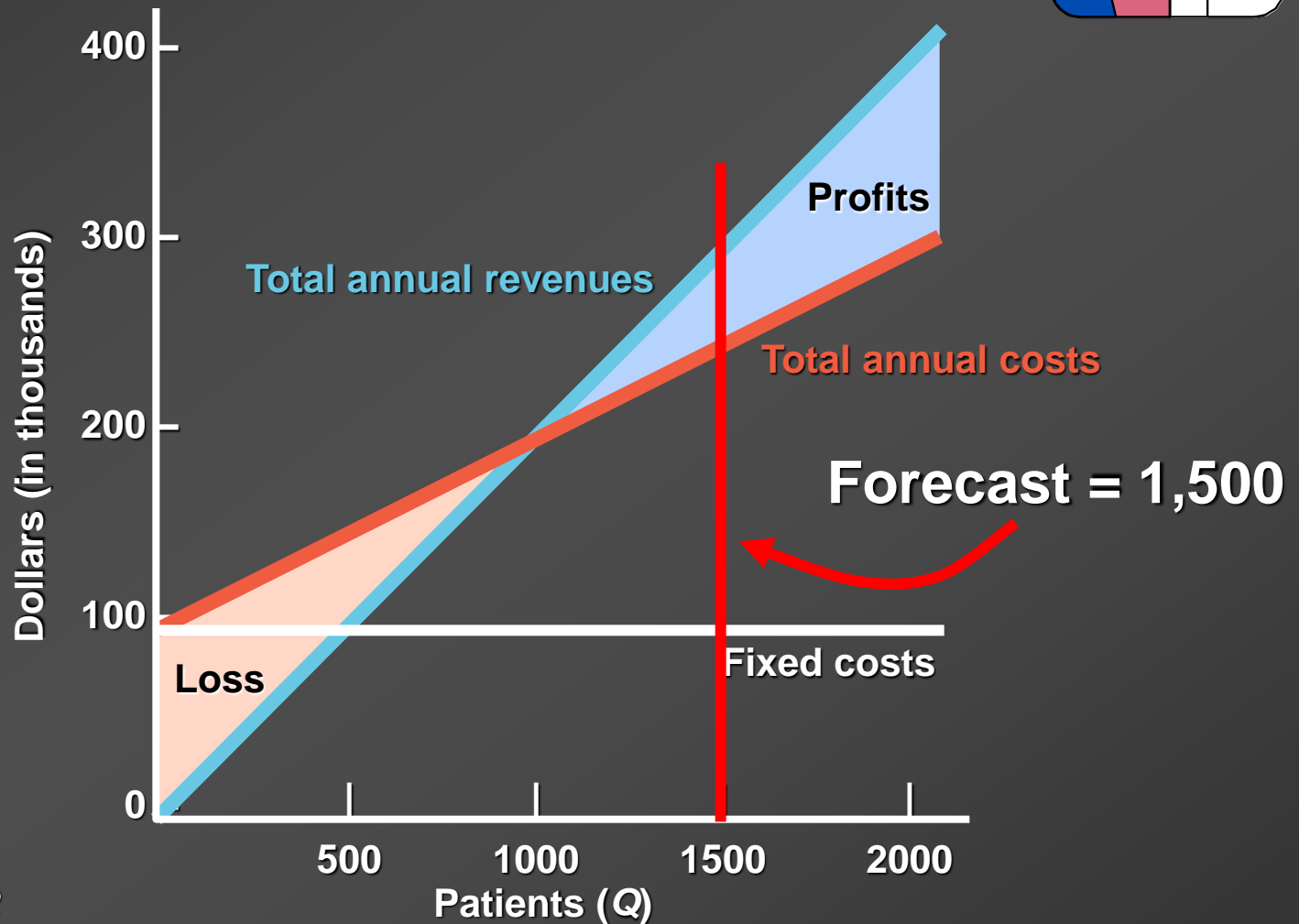

Example A.2

Sensitivity Analysis



$$pQ - (F + cQ)$$

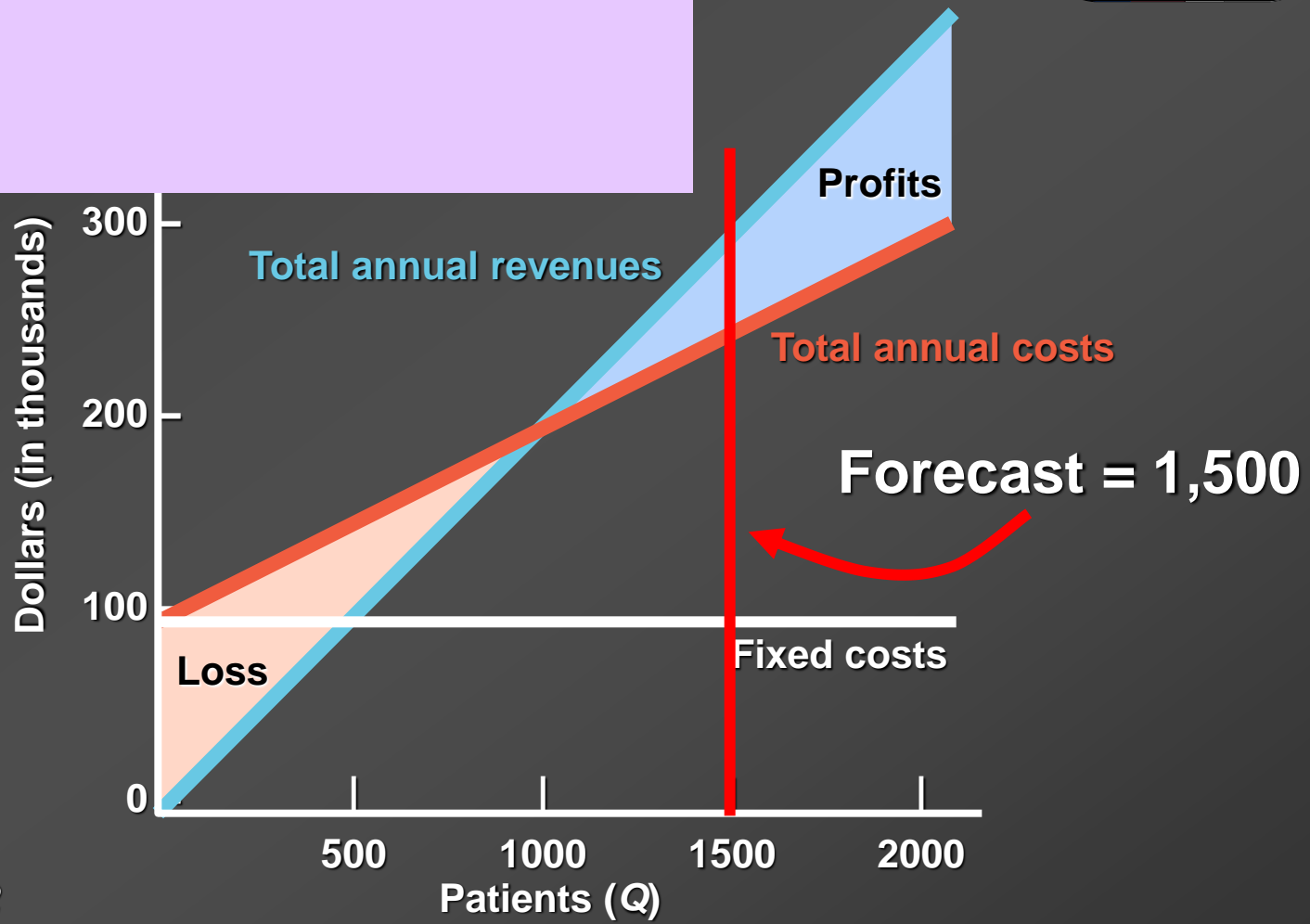

Example A.2

Sensitivity Analysis



$$pQ - (F + cQ)$$
$$200(1500) - [100,000 + 100(1500)]$$
$$\text{\$50,000}$$

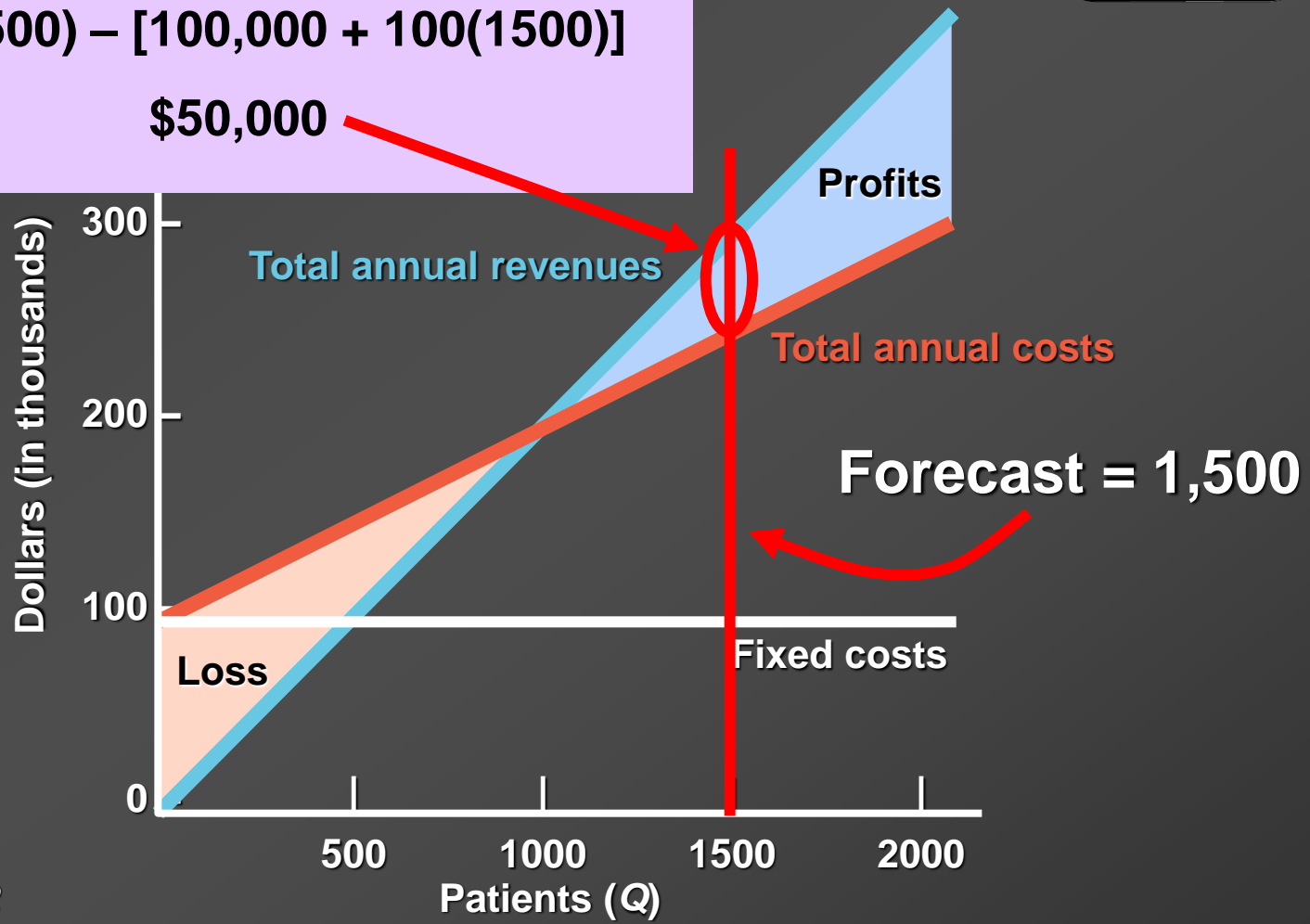

Example A.2

Make-or-Buy Decisions



Evaluating processes

The manager of a fast-food restaurant featuring hamburgers is adding salads to the menu.

There are two options, and the price to the customer will be the same for each. The make option is to install a salad bar stocked with vegetables, fruits, and toppings and let the customer assemble the salad. The salad bar would have to be leased and a part-time employee hired. The manager estimates the fixed costs at \$12,000 and variable costs totaling \$1.50 per salad. The buy option is to have preassembled salads available for sale. They would be purchased from a local supplier at \$2.00 per salad. Offering preassembled salads would require installation and operation of additional refrigeration, with an annual fixed cost of \$2,400. The manager expects to sell 25,000 salads per year.

What is the break-even quantity?

Make-or-Buy Decisions

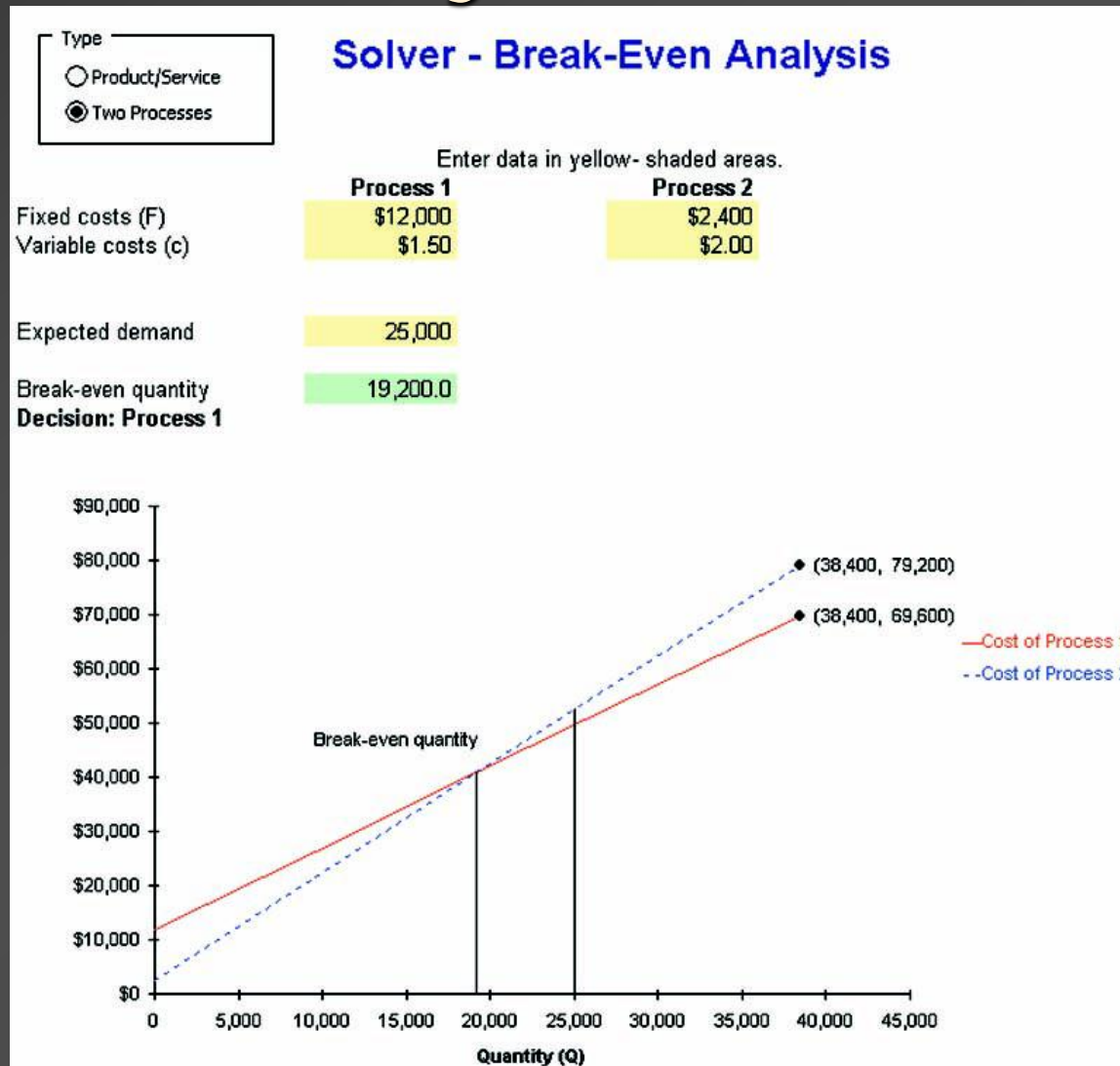
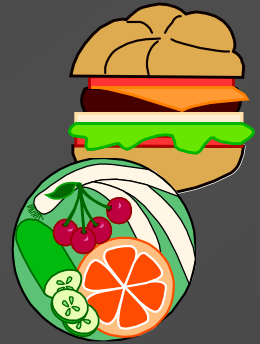
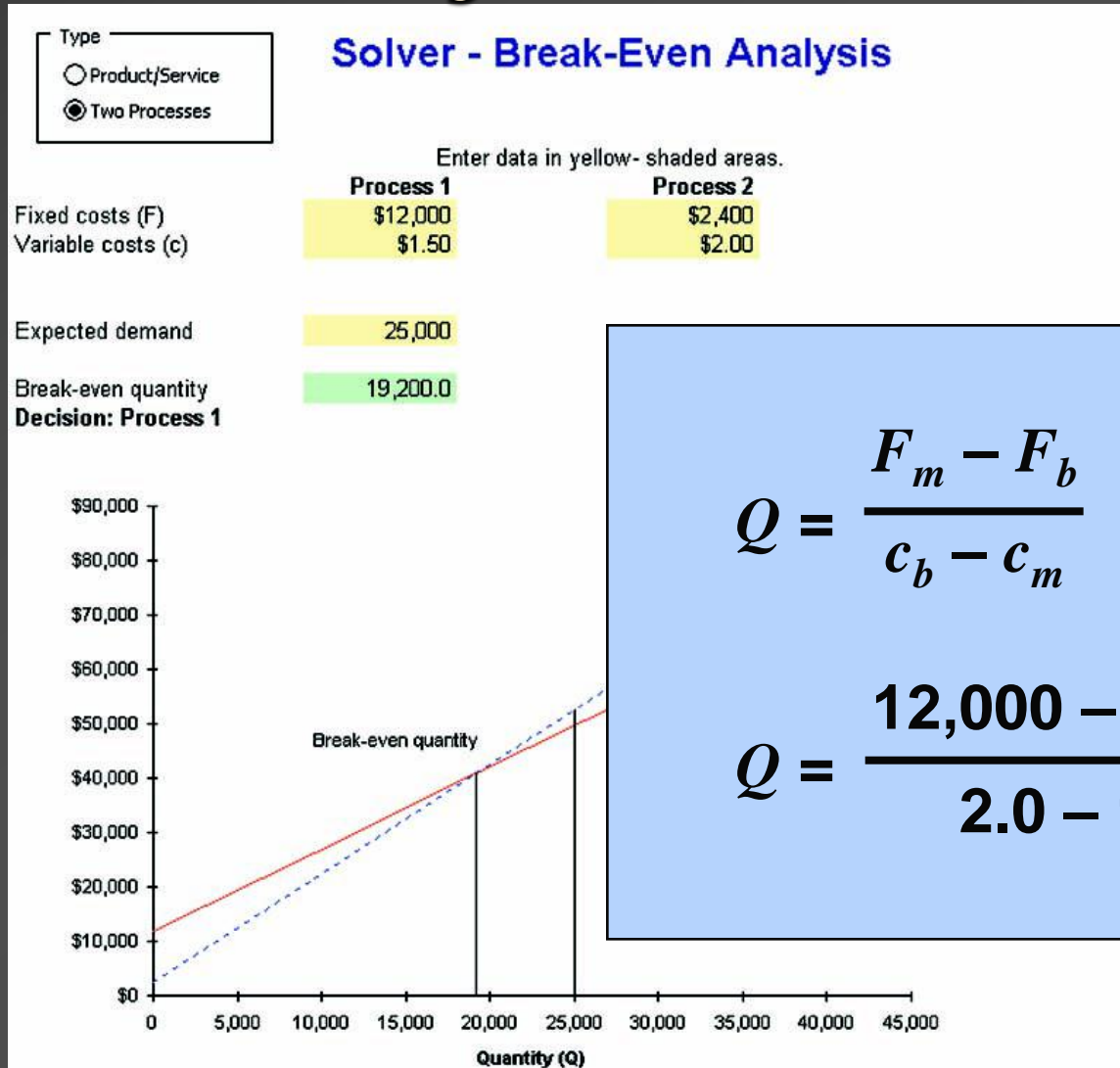
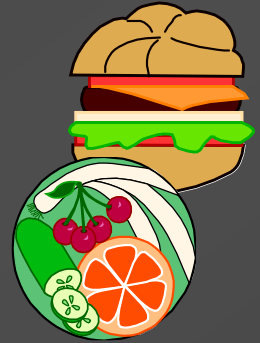

Figure A.2

Make-or-Buy Decisions



Example A.3

Make-or-Buy Decisions

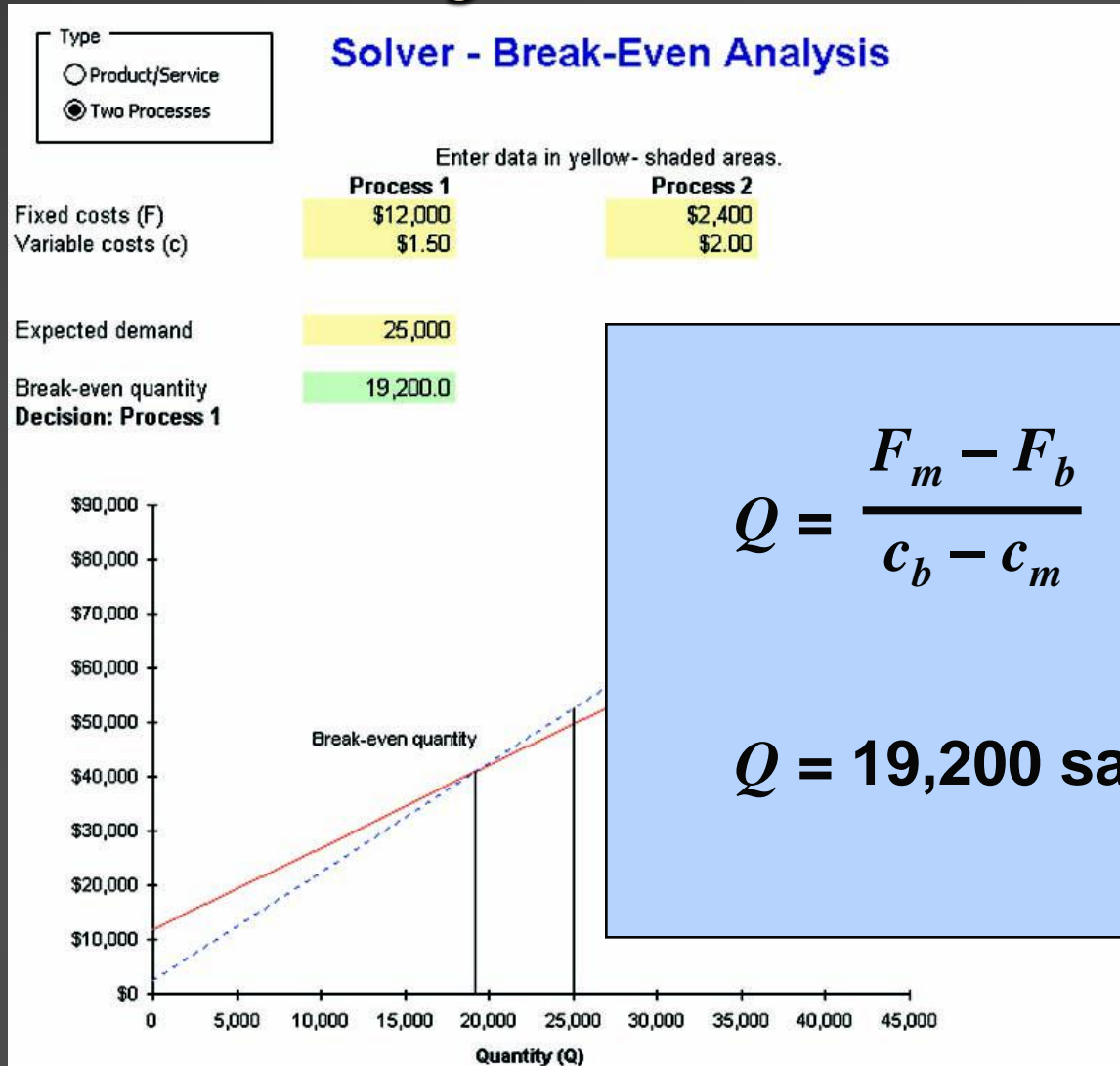
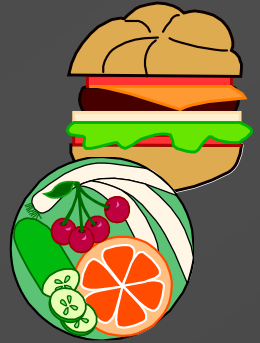

Example A.3

Preference Matrix

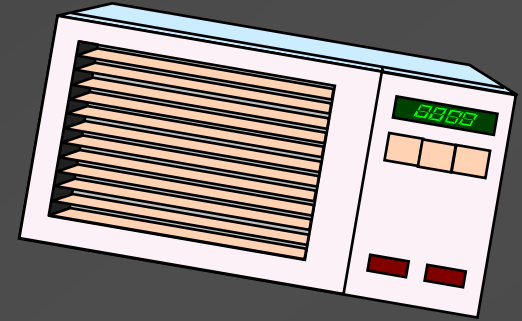

Preference Matrix

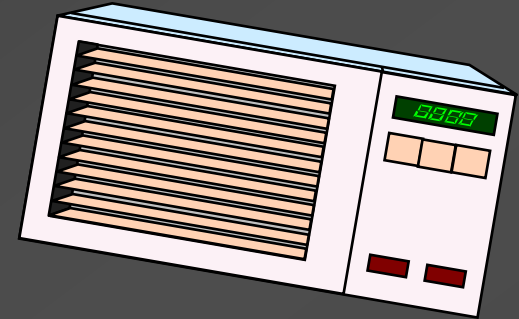

Threshold score = 800

Performance Criterion	Weight (A)	Score (B)	Weighted Score (A x B)
Market potential			
Unit profit margin			
Operations compatibility			
Competitive advantage			
Investment requirement			
Project risk			

Example A.4

Preference Matrix

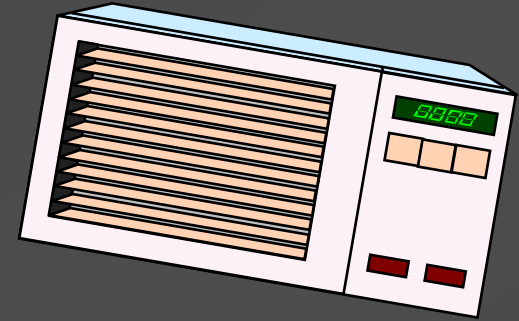

Threshold score = 800

Performance Criterion	Weight (A)	Score (B)	Weighted Score (A x B)
Market potential	30		
Unit profit margin	20		
Operations compatibility	20		
Competitive advantage	15		
Investment requirement	10		
Project risk	5		

Example A.4

Preference Matrix

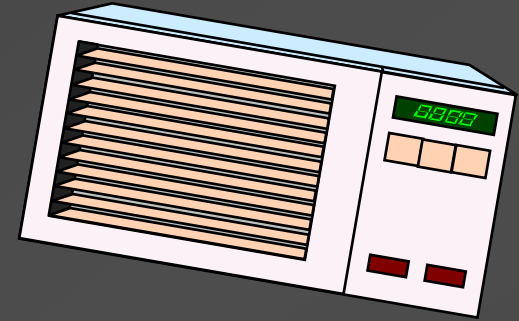

Threshold score = 800

Performance Criterion	Weight (A)	Score (B)	Weighted Score (A x B)
Market potential	30	8	
Unit profit margin	20	10	
Operations compatibility	20	6	
Competitive advantage	15	10	
Investment requirement	10	2	
Project risk	5	4	

Example A.4

Preference Matrix

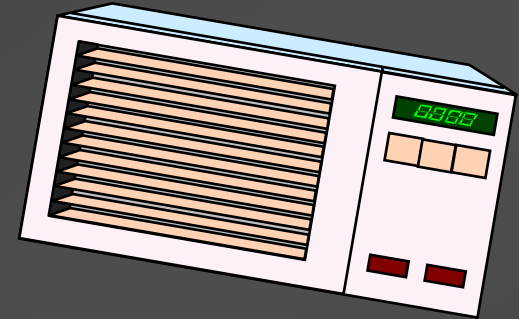

Threshold score = 800

Performance Criterion	Weight (A)	Score (B)	Weighted Score (A x B)
Market potential	30	8	240
Unit profit margin	20	10	200
Operations compatibility	20	6	120
Competitive advantage	15	10	150
Investment requirement	10	2	20
Project risk	5	4	20

Example A.4

Preference Matrix

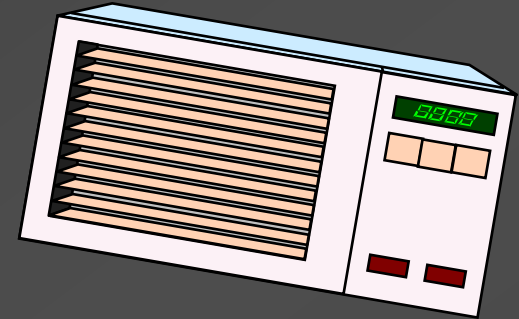

Threshold score = 800

Performance Criterion	Weight (A)	Score (B)	Weighted Score (A x B)
Market potential	30	8	240
Unit profit margin	20	10	200
Operations compatibility	20	6	120
Competitive advantage	15	10	150
Investment requirement	10	2	20
Project risk	5	4	20
			<u>750</u>
			<u><u>750</u></u>

Example A.4

Preference Matrix

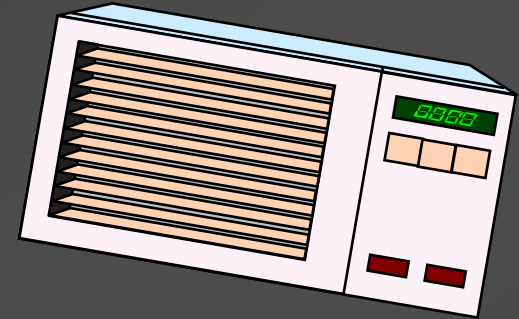

Threshold score = 800

Performance Criterion	Weight (A)	Score (B)	Weighted Score (A x B)
Market potential	30	8	240
Unit profit margin	20	10	200
Operations compatibility	20	6	120
Competitive advantage	15	10	150
Investment requirement	10	2	20
Project risk	5	4	20
			<u>750</u>

Weighted score = 750

< 800

Example A.4

Preference Matrix

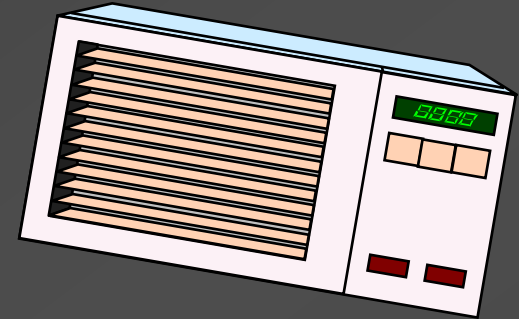

Threshold score = 800

Performance Criterion	Weight (A)	Score (B)	Weighted Score (A * B)
Market potential	30	8	240
Unit profit margin	20	10	200
Operations compatibility	20	6	120
Competitive advantage	15	10	150
Investment requirements	10	2	20
Project risk	5	4	20
			<u>750</u>

Weighted score = 750

Not At This Time

Example A.4

3- decision theory

- *List the feasible alternatives*
- *List the events*
- *Calculate the payoff*
- *Estimate the likelihood of each events*
- *Select a decision rule*

Under Certainty

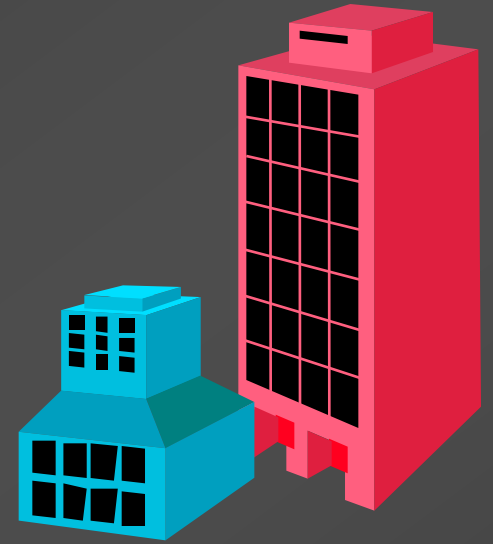

Under Certainty

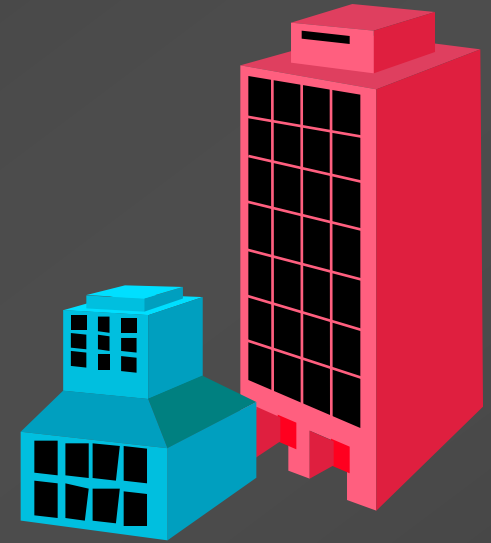

Alternative	Possible Future Demand	
	Low	High
Small facility	200	270
Large facility	160	800
Do nothing	0	0

Example A.5

Under Certainty

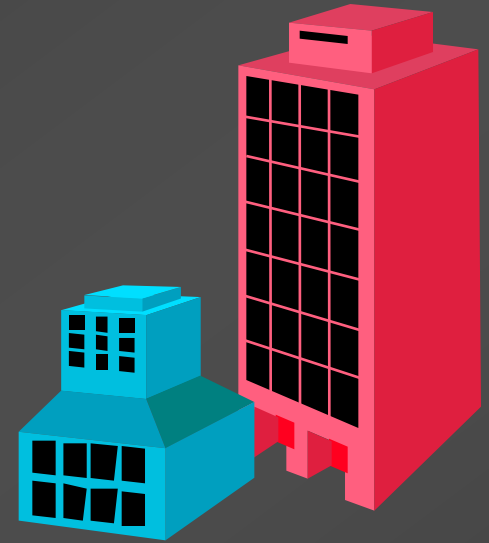

Alternative	Possible Future Demand	
	Low	High
Small facility	200	270
Large facility	160	800
Do nothing	0	0

If future demand will be low –

Example A.5

Under Certainty

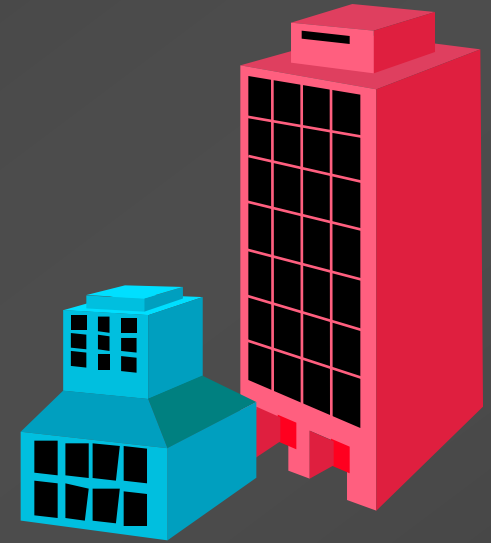

Possible Future Demand

<u>Alternative</u>	<u>Low</u>	<u>High</u>
Small facility	200	270
Large facility	160	800
Do nothing	0	0

If future demand will be low – Choose the small facility.

Example A.5

Under Certainty

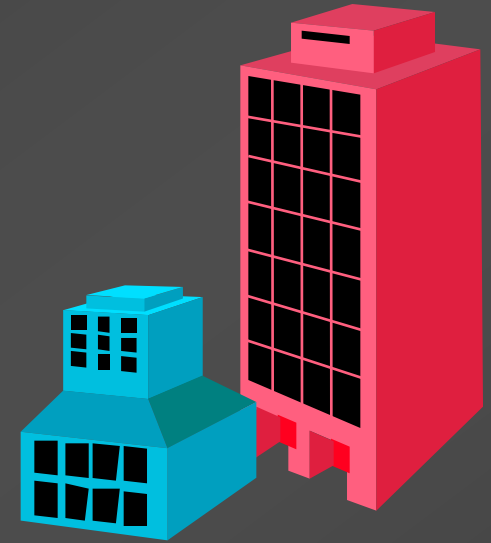

Possible Future Demand

Alternative	Low	High
Small facility	200	270
Large facility	160	800
Do nothing	0	0

If future demand will be low – Choose the small facility.

Example A.5

Under Uncertainty



Alternative	Possible Future Demand	
	Low	High
Small facility	200	270
Large facility	160	800
Do nothing	0	0

Example A.6

Under Uncertainty



Possible Future Demand

Alternative	Low	High
Small facility	200	270
Large facility	160	800
Do nothing	0	0

Maximin –

Under Uncertainty



Alternative	Possible Future Demand	
	Low	High
Small facility	200	270
Large facility	160	800
Do nothing	0	0

Maximin –

Best of the worst

Under Uncertainty



Alternative	Possible Future Demand	
	Low	High
Small facility	200	270
Large facility	160	800
Do nothing	0	0

Maximin – Small

Best of the worst

Under Uncertainty



Alternative	Possible Future Demand	
	Low	High
Small facility	200	270
Large facility	160	800
Do nothing	0	0

Maximin – Small
Maximax –

Under Uncertainty



Alternative	Possible Future Demand	
	Low	High
Small facility	200	270
Large facility	160	800
Do nothing	0	0

Maximin – Small
Maximax –

Best of the best

Under Uncertainty



Alternative	Possible Future Demand	
	Low	High
Small facility	200	270
Large facility	160	800
Do nothing	0	0

Maximin – Small
Maximax – Large

Best of the best

Under Uncertainty



Alternative	Possible Future Demand	
	Low	High
Small facility	200	270
Large facility	160	800
Do nothing	0	0

Maximin – Small
Maximax – Large
Laplace –

Under Uncertainty



Alternative	Possible Future Demand	
	Low	High
Small facility	200	270
Large facility	160	800
Do nothing	0	0

Maximin – Small
Maximax – Large
Laplace –

Small facility

$$0.5(200) + 0.5(270) = 235$$

**Best
weighted
payoff**

Under Uncertainty



Possible Future Demand

Alternative	Low	High
Small facility	200	270
Large facility	160	800
Do nothing	0	0

Maximin – Small
 Maximax – Large
 Laplace –

Small facility $0.5(200) + 0.5(270) = 235$
 Large facility $0.5(160) + 0.5(800) = 480$

**Best
 weighted
 payoff**

Under Uncertainty



Alternative	Possible Future Demand	
	Low	High
Small facility	200	270
Large facility	160	800
Do nothing	0	0

Maximin – Small
Maximax – Large
Laplace – Large

Small facility
Large facility

$$0.5(200) + 0.5(270) = 235$$
$$0.5(160) + 0.5(800) = 480$$

*Best
weighted
payoff*

Under Uncertainty



Alternative	Possible Future Demand	
	Low	High
Small facility	200	270
Large facility	160	800
Do nothing	0	0

Maximin – Small
Maximax – Large
Laplace – Large
Minimax Regret –

Under Uncertainty



Alternative	Possible Future Demand		
	Low	High	
Small facility	200	270	Maximin – Small
Large facility	160	800	Maximax – Large
Do nothing	0	0	Laplace – Large
			Minimax Regret –

	Regret	
	Low Demand	High Demand
Small facility	$200 - 200 = 0$	$800 - 270 = 530$

**Best
worst
regret**

Under Uncertainty



Possible Future Demand

Alternative	Low	High
Small facility	200	270
Large facility	160	800
Do nothing	0	0

Maximin – Small
 Maximax – Large
 Laplace – Large
 Minimax Regret –

Regret

	Low Demand	High Demand
Small facility	$200 - 200 = 0$	$800 - 270 = 530$
Large facility	$200 - 160 = 40$	$800 - 800 = 0$

Best
worst
regret

Example A.6

Under Uncertainty



Possible Future Demand

Alternative	Low	High
Small facility	200	270
Large facility	160	800
Do nothing	0	0

- Maximin – Small
- Maximax – Large
- Laplace – Large
- Minimax Regret – Large

Regret

	Low Demand	High Demand
Small facility	$200 - 200 = 0$	$800 - 270 = 530$
Large facility	$200 - 160 = 40$	$800 - 800 = 0$

**Best
worst
regret**

Example A.6

Under Uncertainty



Alternative	Possible Future Demand	
	Low	High
Small facility	200	270
Large facility	160	800
Do nothing	0	0

Maximin – Small
Maximax – Large
Laplace – Large
Minimax Regret – Large

Under Risk

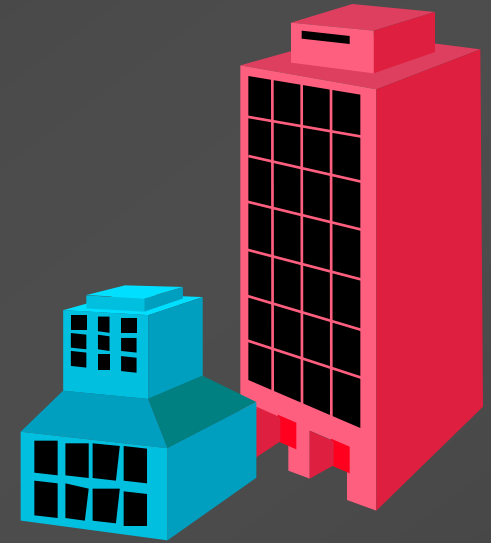

Alternative	Possible Future Demand	
	Low	High
Small facility	200	270
Large facility	160	800
Do nothing	0	0

$$P_{\text{small}} = 0.4$$

$$P_{\text{large}} = 0.6$$

Under Risk

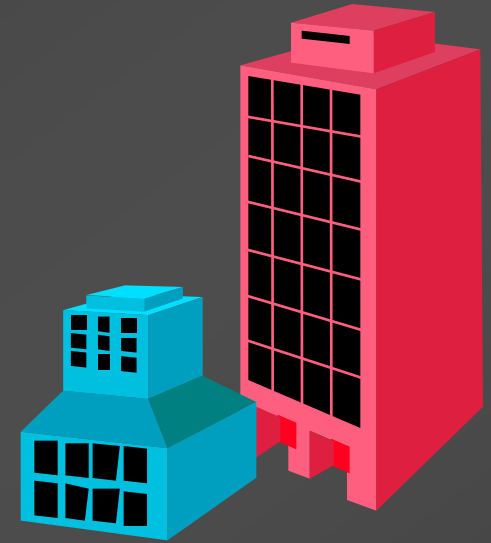

Alternative	Possible Future Demand	
	Low	High
Small facility	200	270
Large facility	160	800
Do nothing	0	0

Alternative	Expected Value
Small facility	$0.4(200) + 0.6(270) = 242$

$$P_{\text{small}} = 0.4$$

$$P_{\text{large}} = 0.6$$

Under Risk

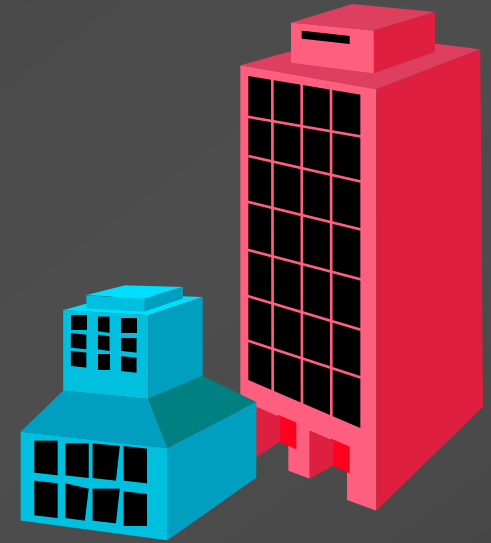

Alternative	Possible Future Demand	
	Low	High
Small facility	200	270
Large facility	160	800
Do nothing	0	0

$$P_{\text{small}} = 0.4$$

$$P_{\text{large}} = 0.6$$

Alternative	Expected Value
Small facility	$0.4(200) + 0.6(270) = 242$
Large facility	$0.4(160) + 0.6(800) = 544$

Example A.7

Under Risk

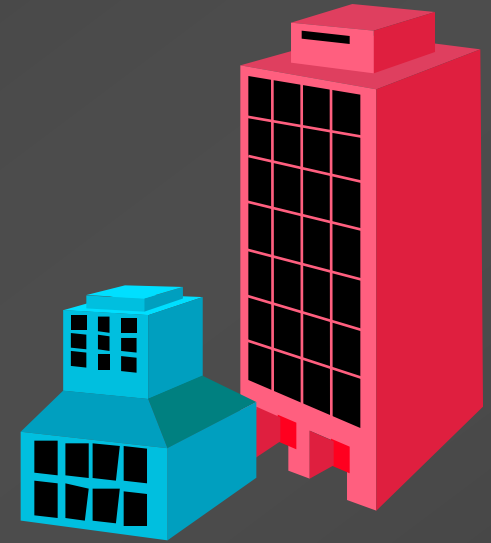

Alternative	Possible Future Demand	
	Low	High
Small facility	200	270
Large facility	160	800
Do nothing	0	0

$$P_{\text{small}} = 0.4$$

$$P_{\text{large}} = 0.6$$

Alternative	Expected Value
Small facility	$0.4(200) + 0.6(270) = 242$
Large facility	$0.4(160) + 0.6(800) = 544$

**Highest
Expected
Value**

Example A.7

Perfect Information

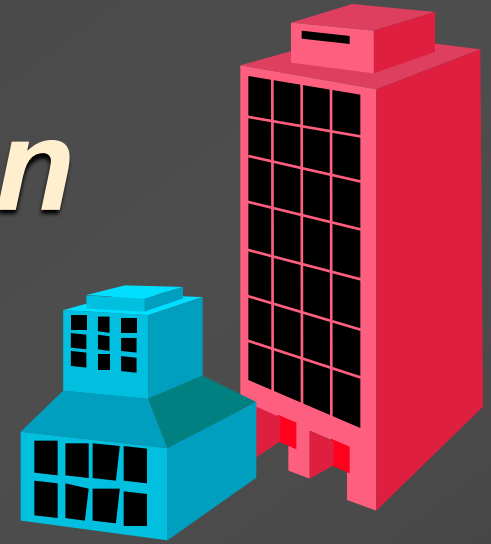

Alternative	Possible Future Demand	
	Low	High
Small facility	200	270
Large facility	160	800
Do nothing	0	0

$$P_{\text{small}} = 0.4$$

$$P_{\text{large}} = 0.6$$

Perfect Information

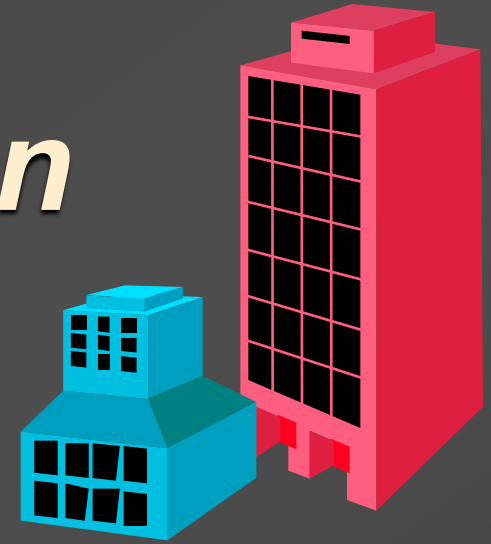

Alternative	Possible Future Demand	
	Low	High
Small facility	200	270
Large facility	160	800
Do nothing	0	0

$$P_{\text{small}} = 0.4$$

$$P_{\text{large}} = 0.6$$

Event	Best Payoff
Low demand	200
High demand	800

Example A.8

Decision Trees

Decision Trees

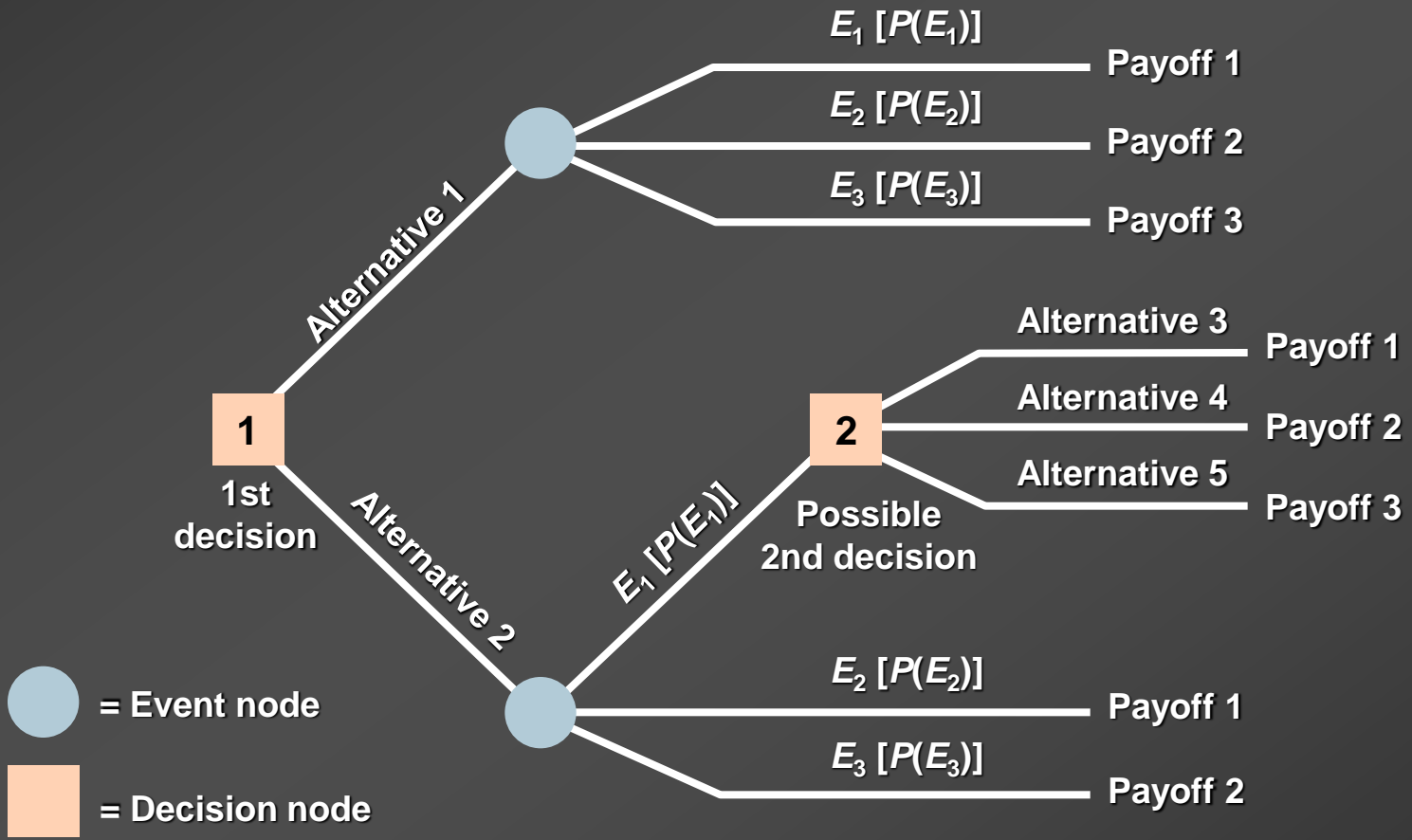
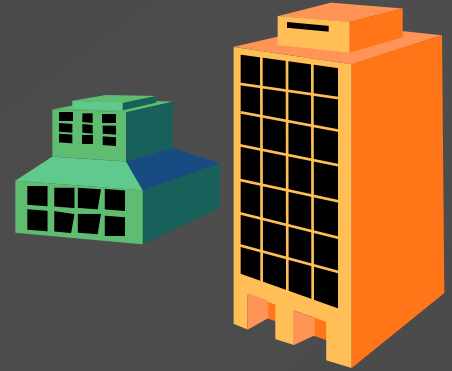
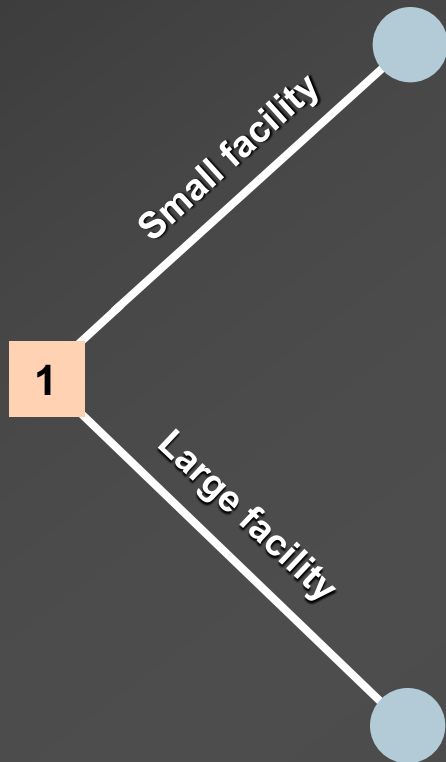
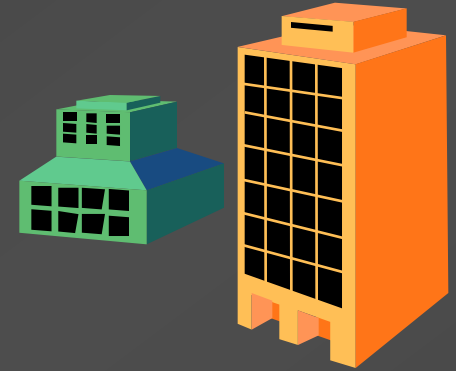

Figure A.5

Decision Trees



Decision Trees



Example A.9

Decision Trees

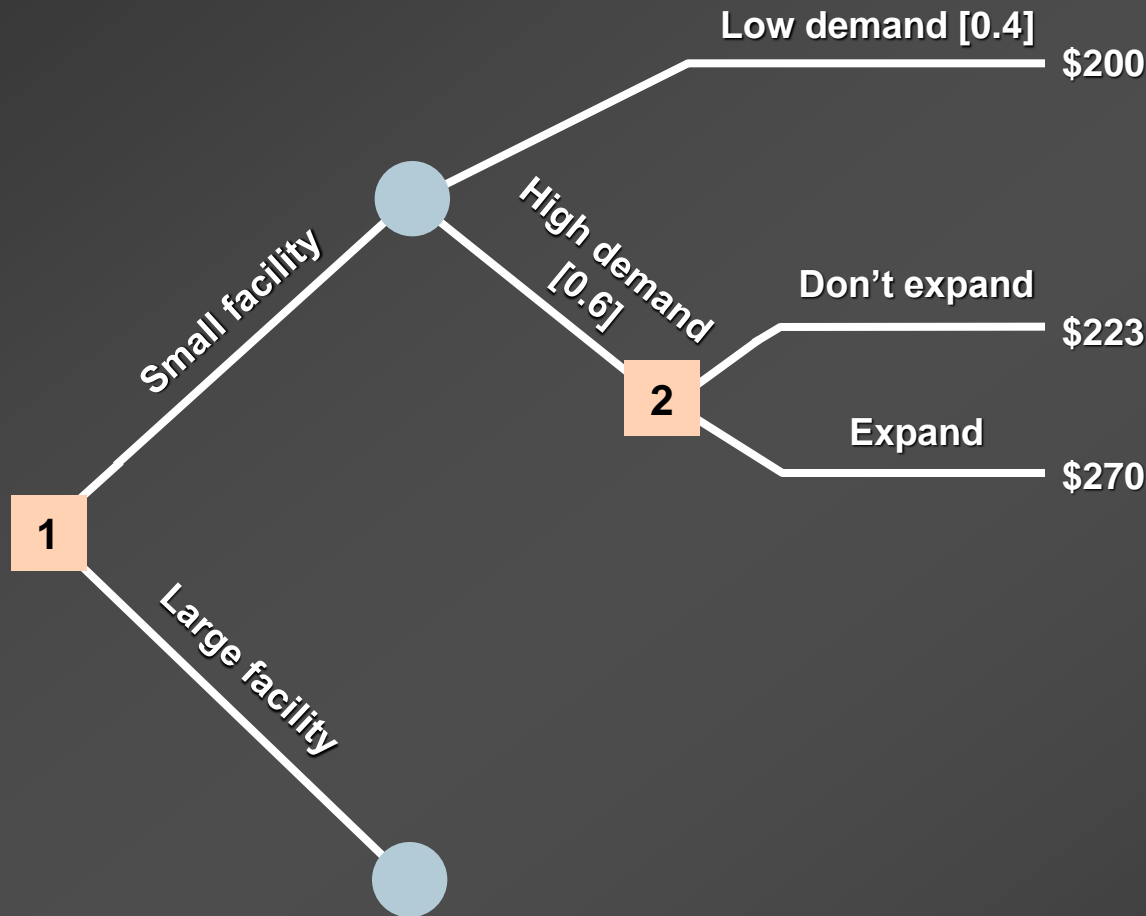
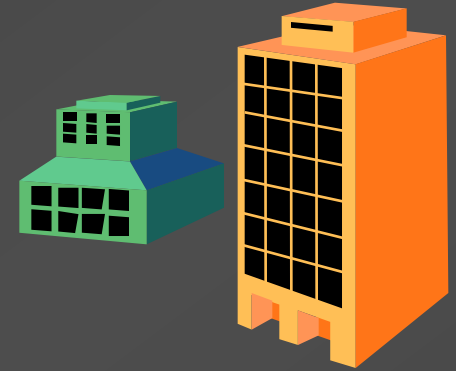

Example A.9

Decision Trees

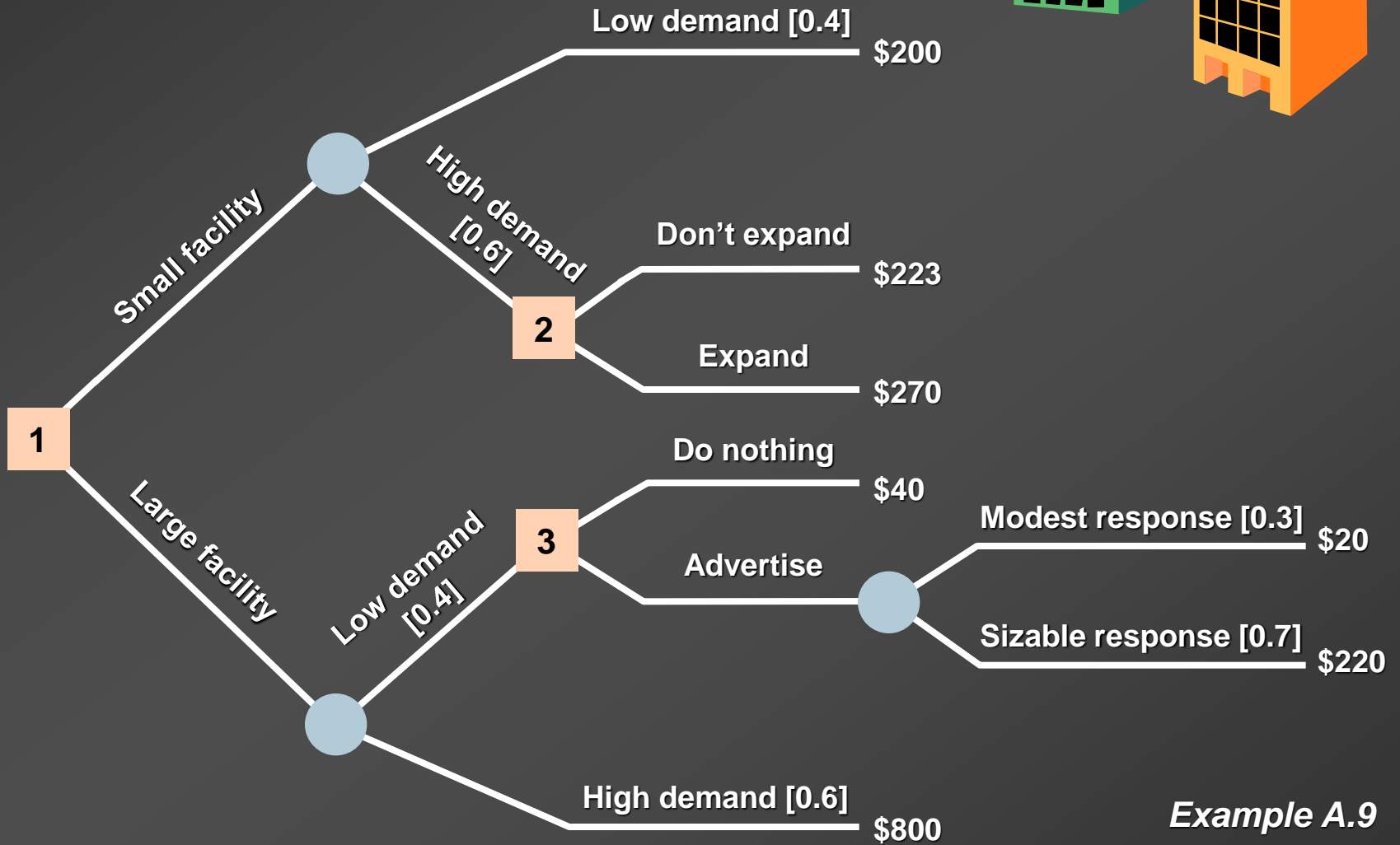
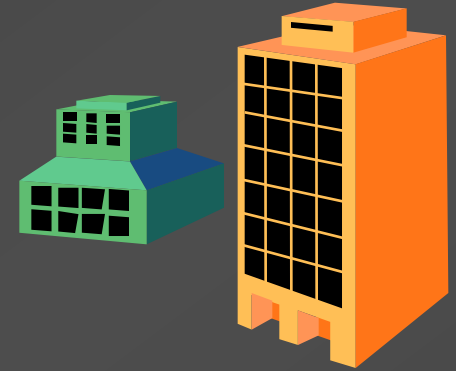

Example A.9

Decision Trees

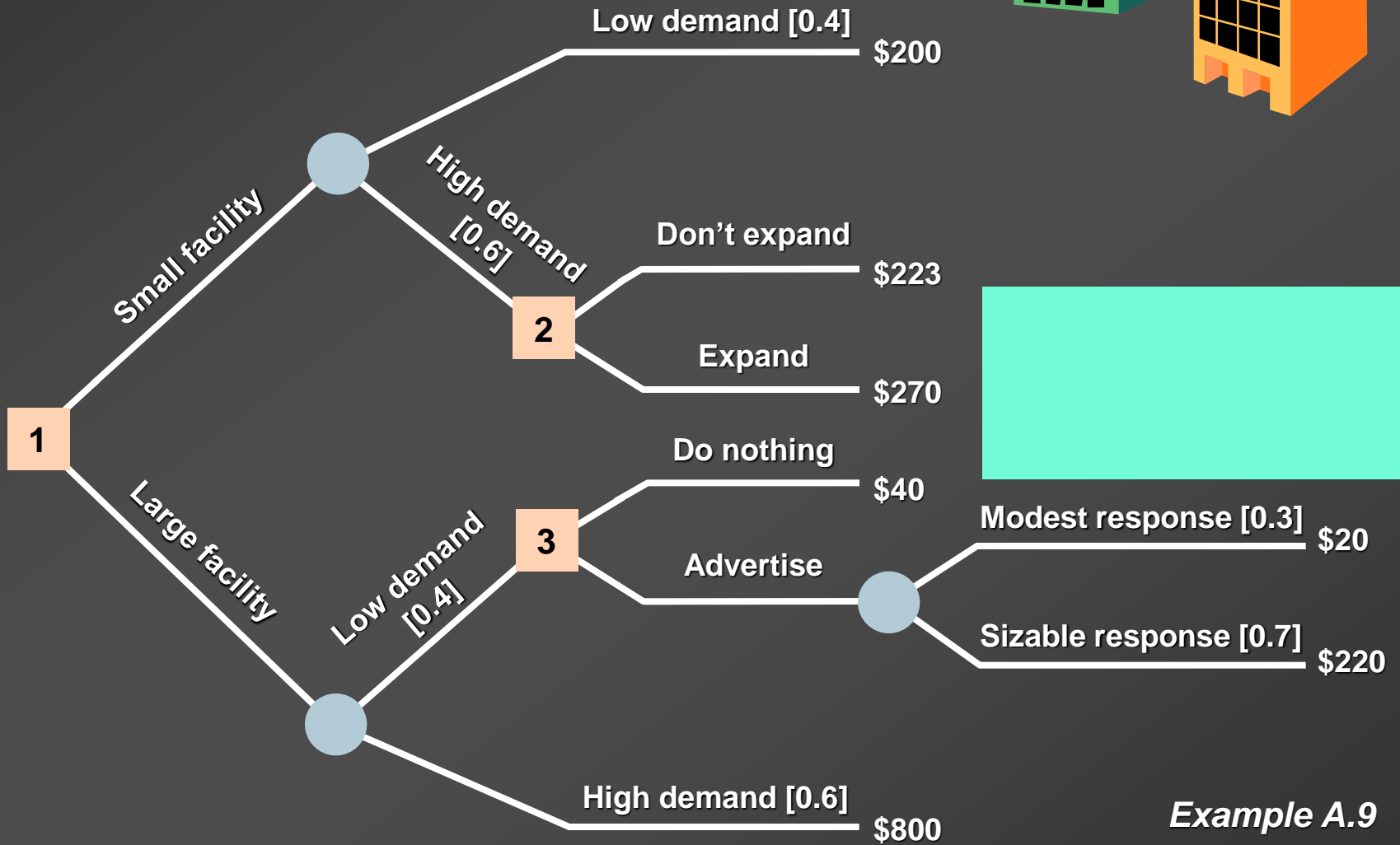
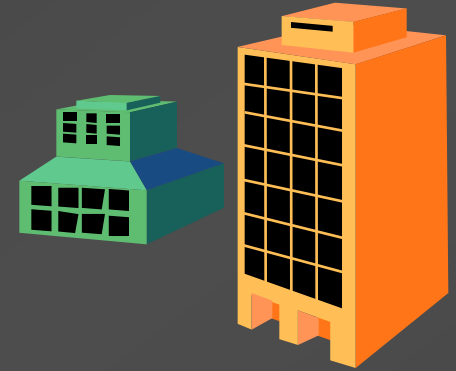

Example A.9

Decision Trees

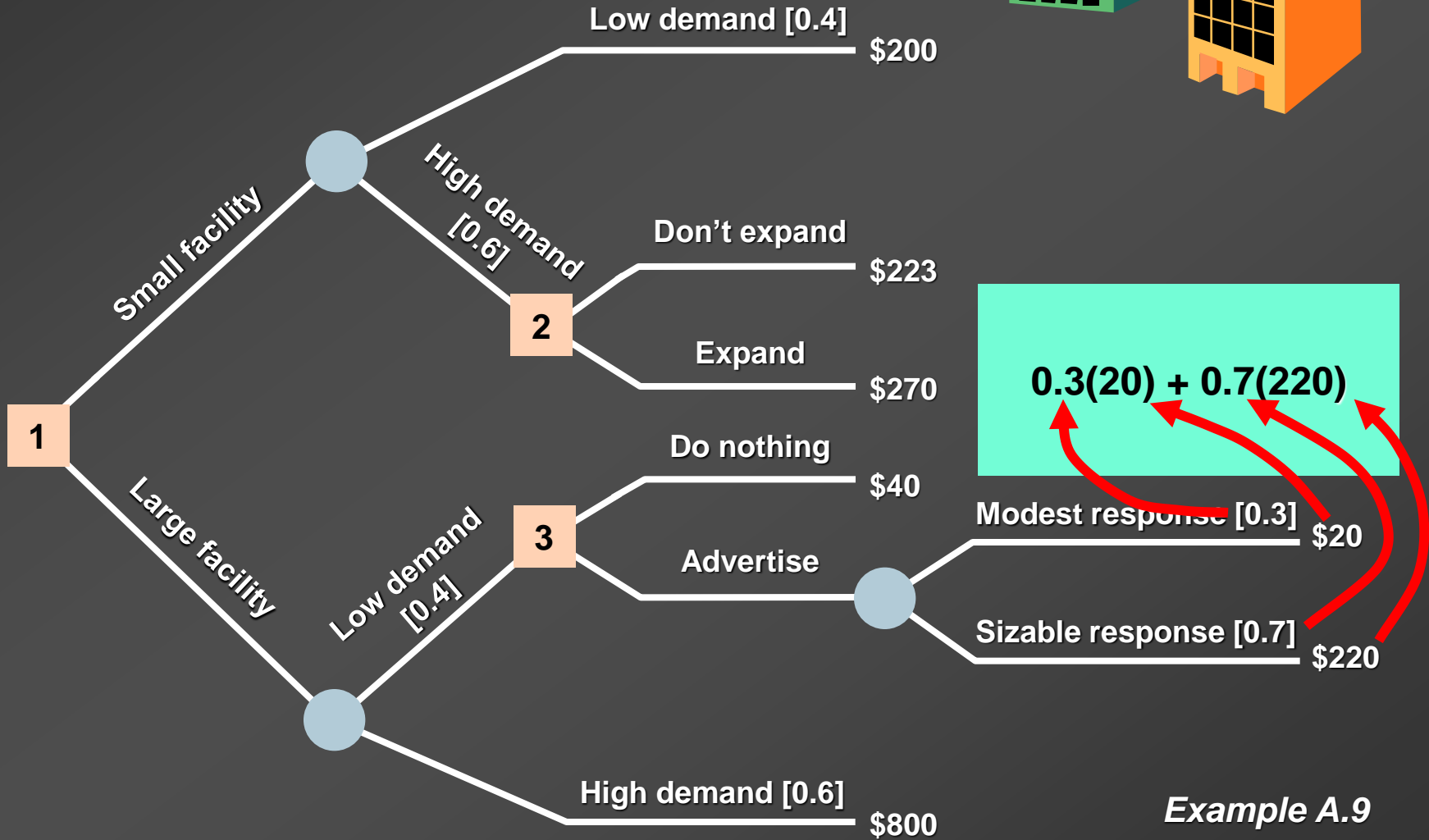
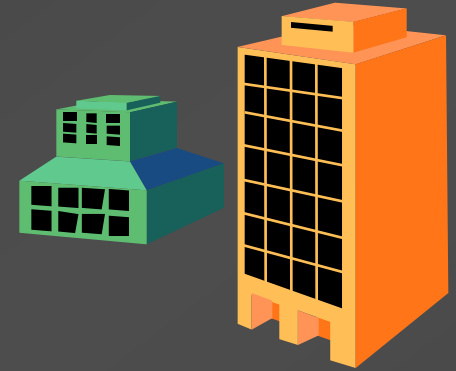

Example A.9

Decision Trees

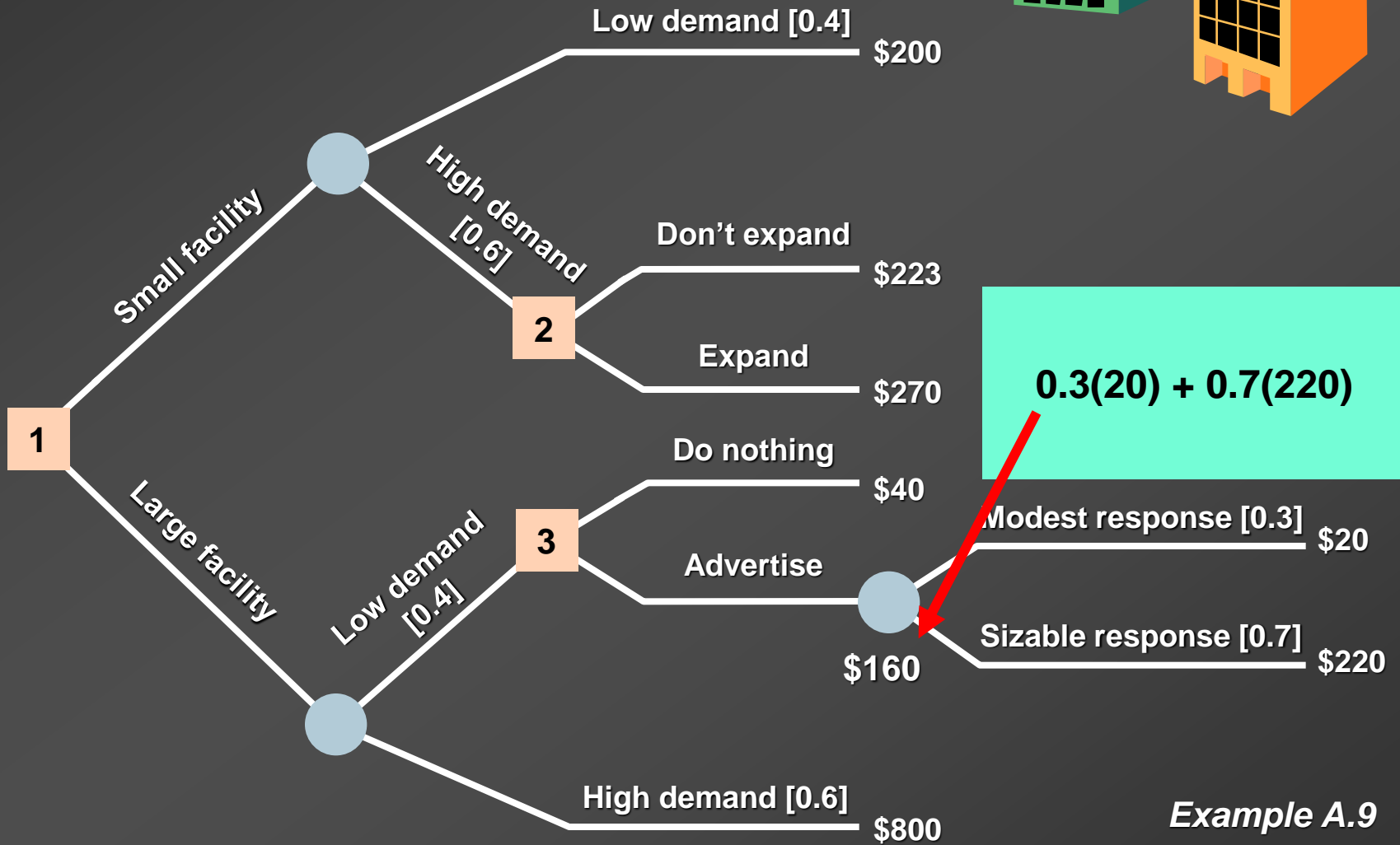
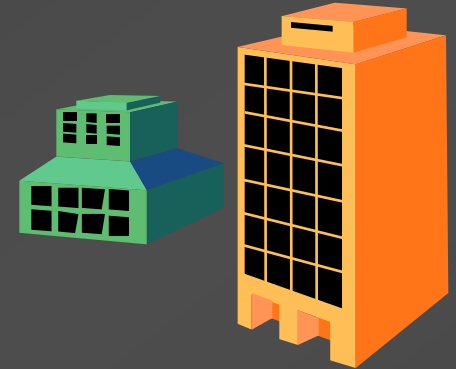

Example A.9

Decision Trees

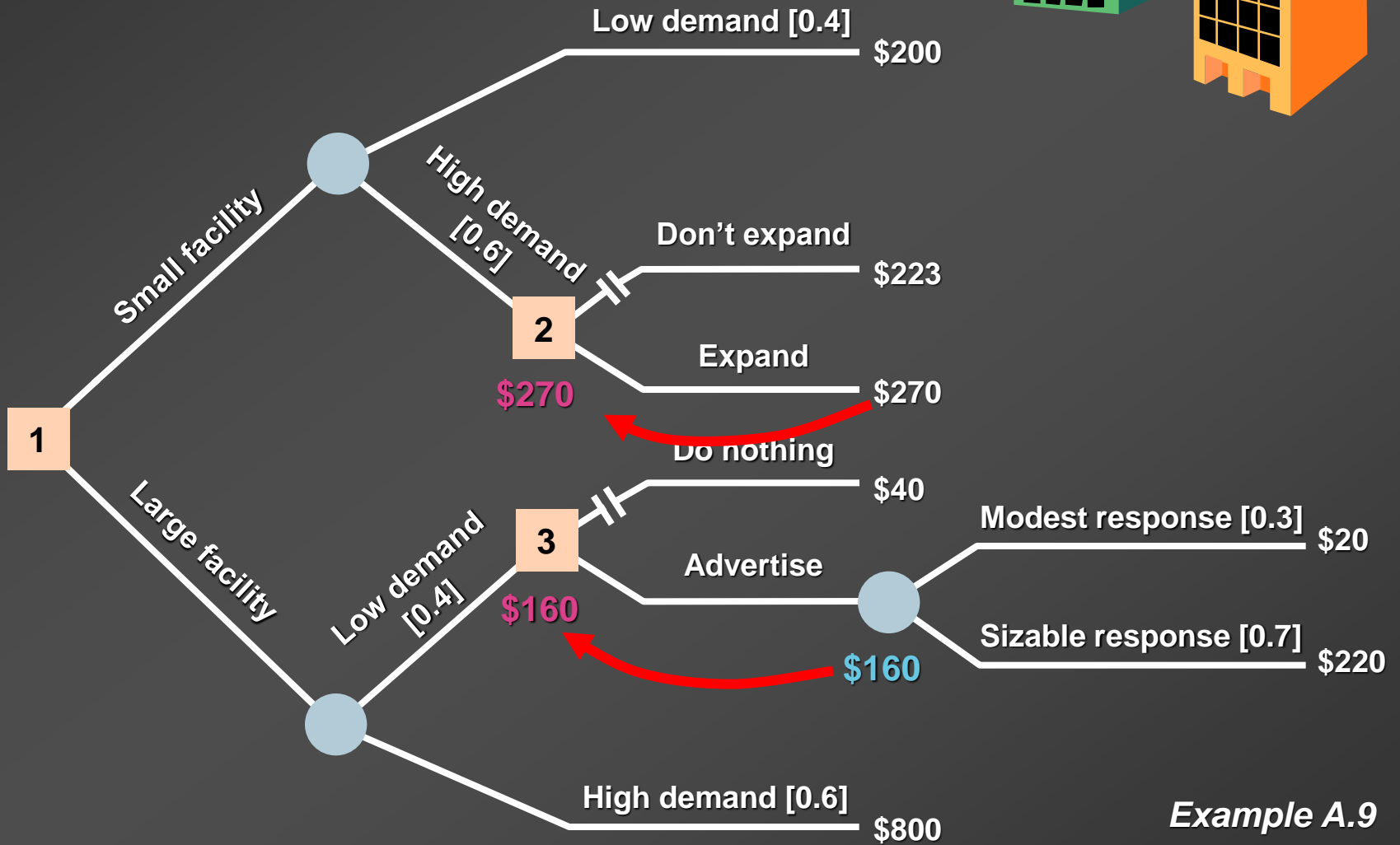
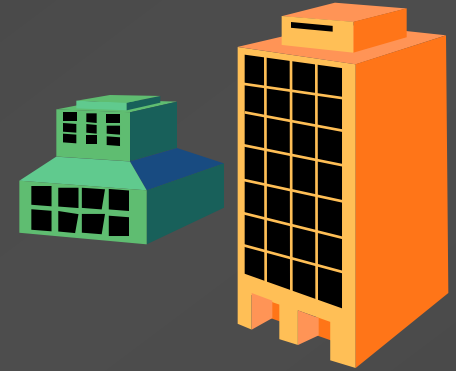

Example A.9

Decision Trees

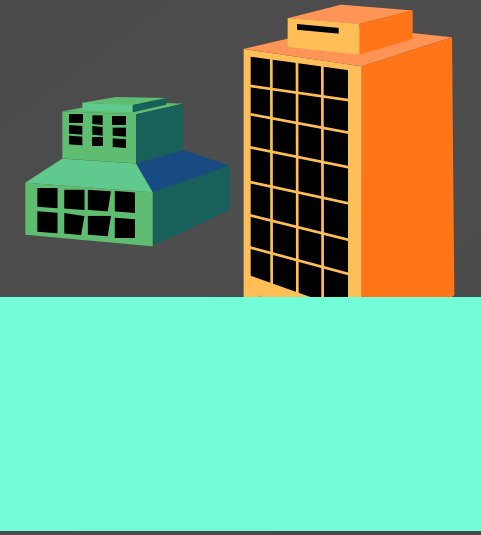
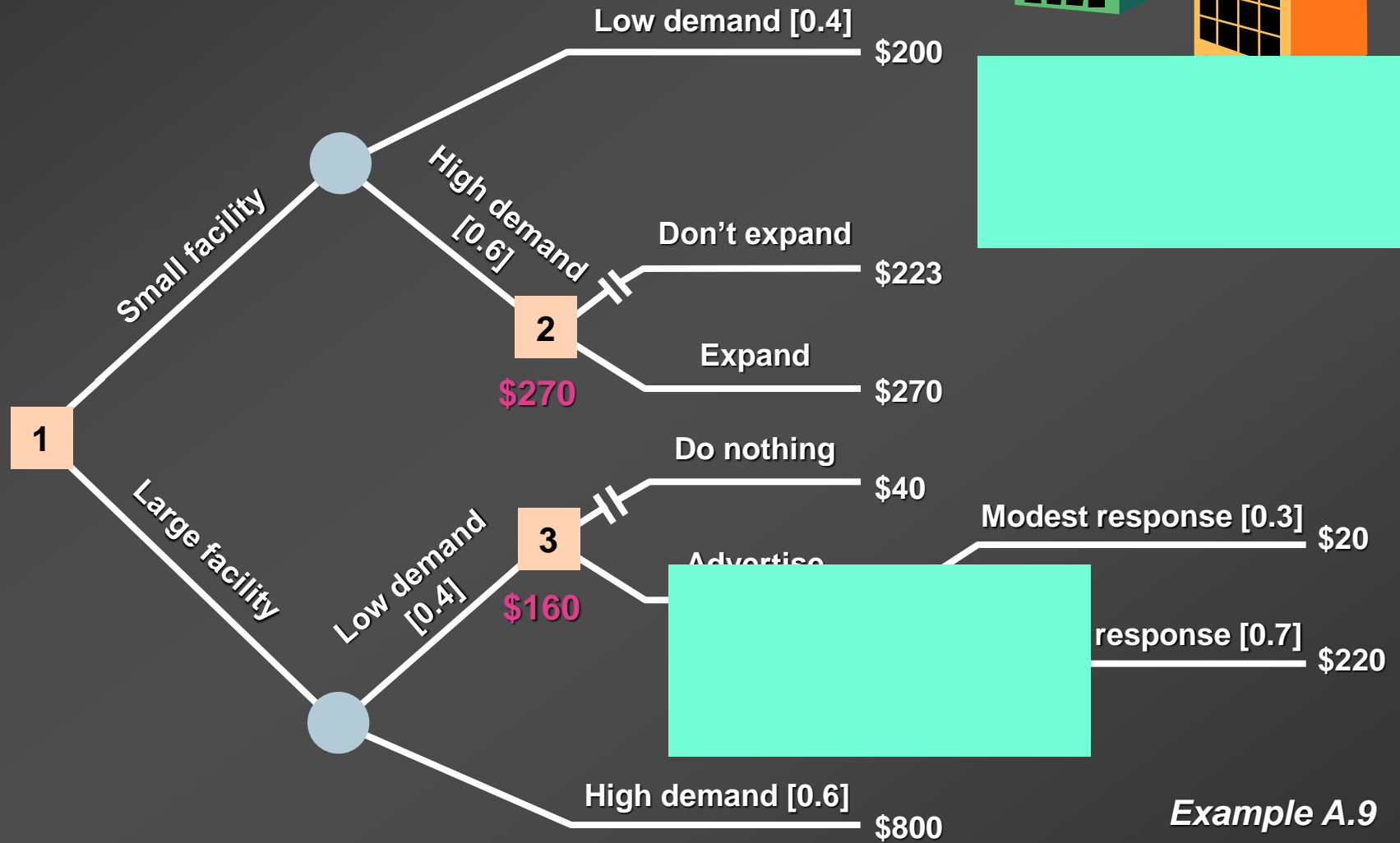

Example A.9

Decision Trees

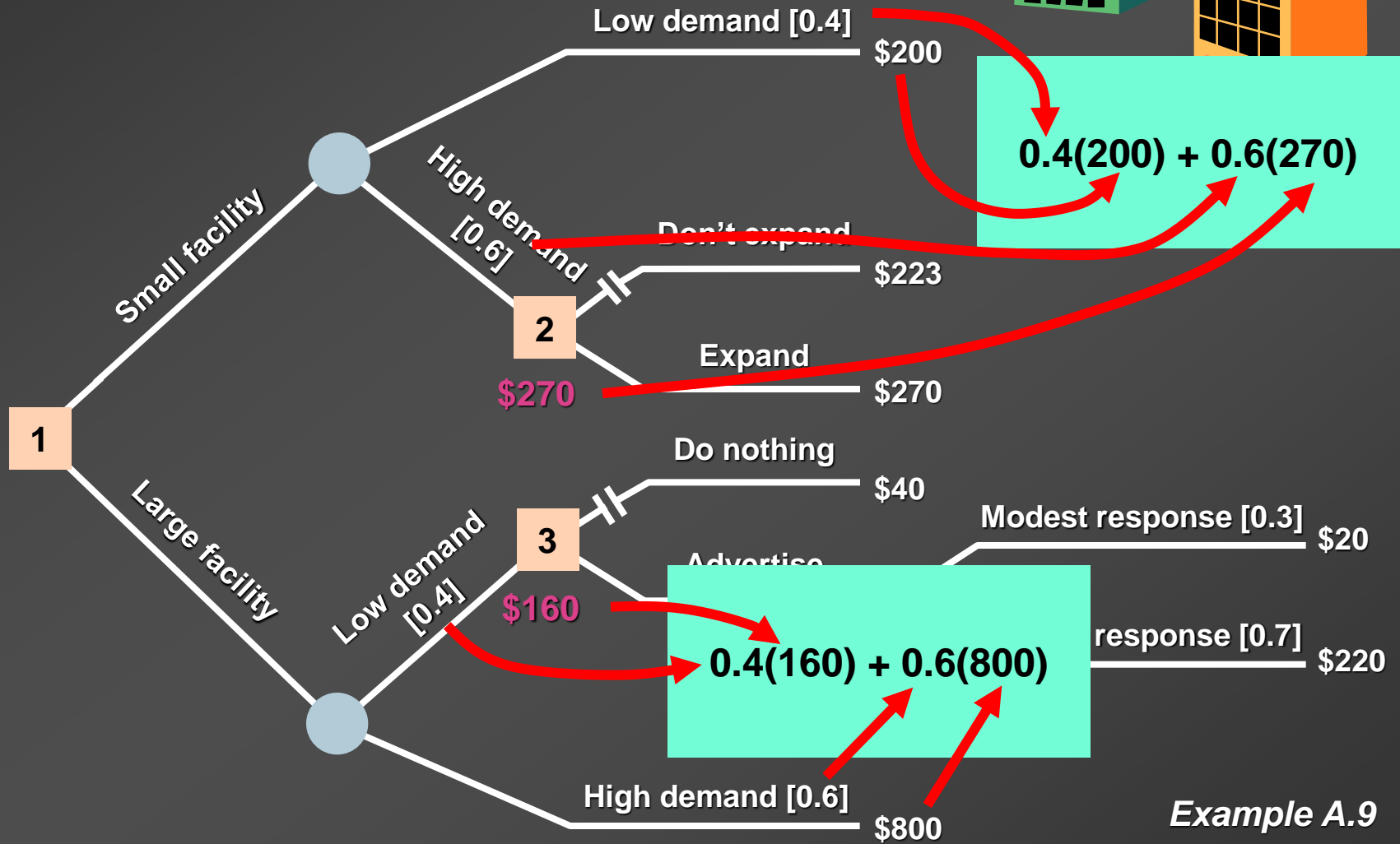
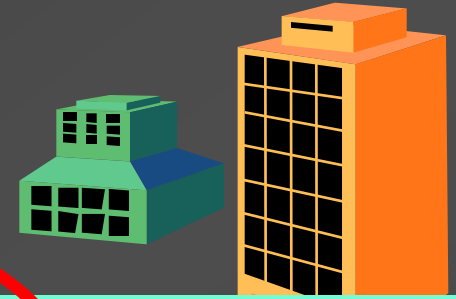

Example A.9

Decision Trees

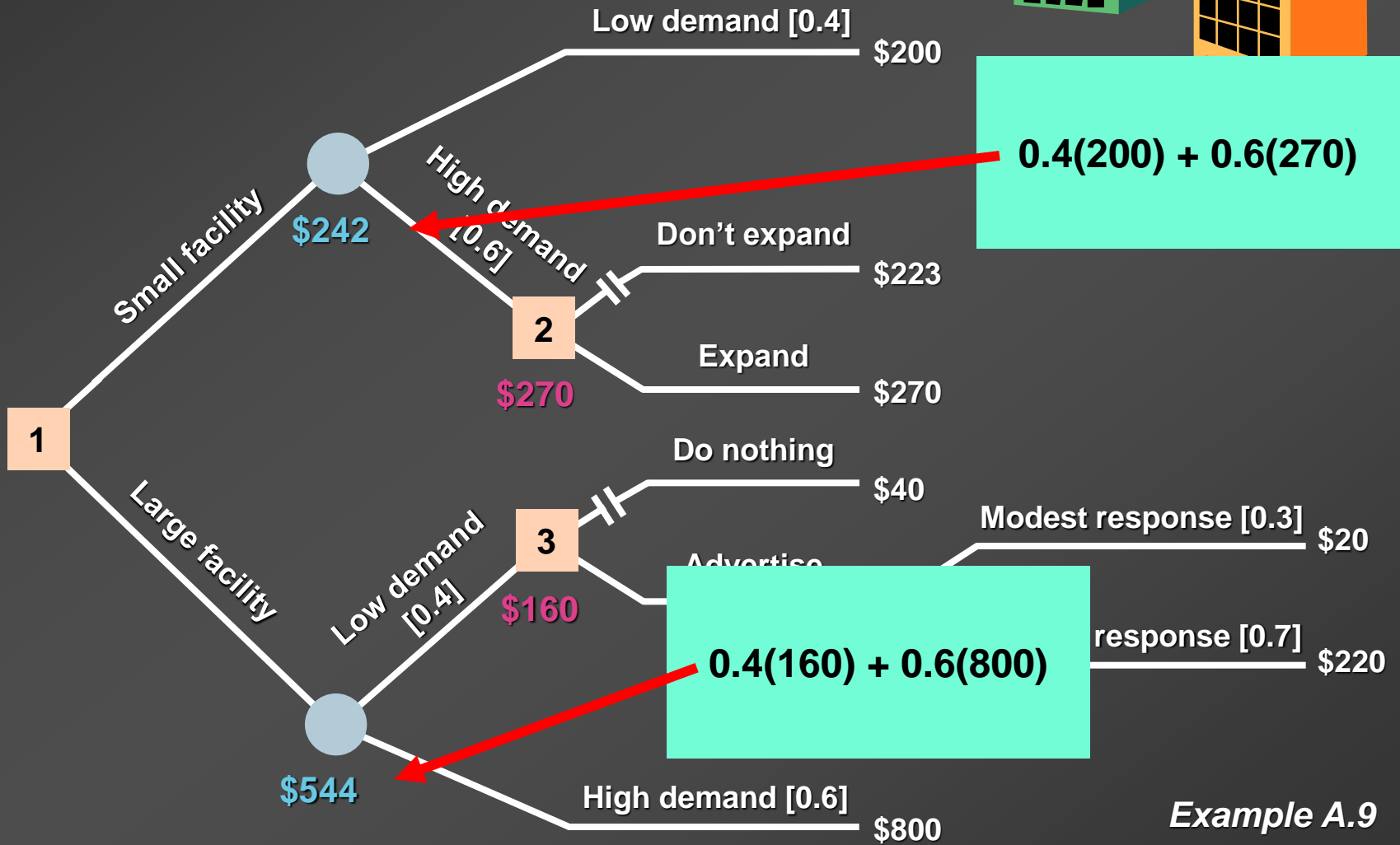
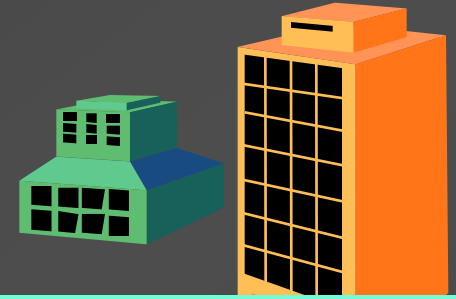

Example A.9

Decision Trees

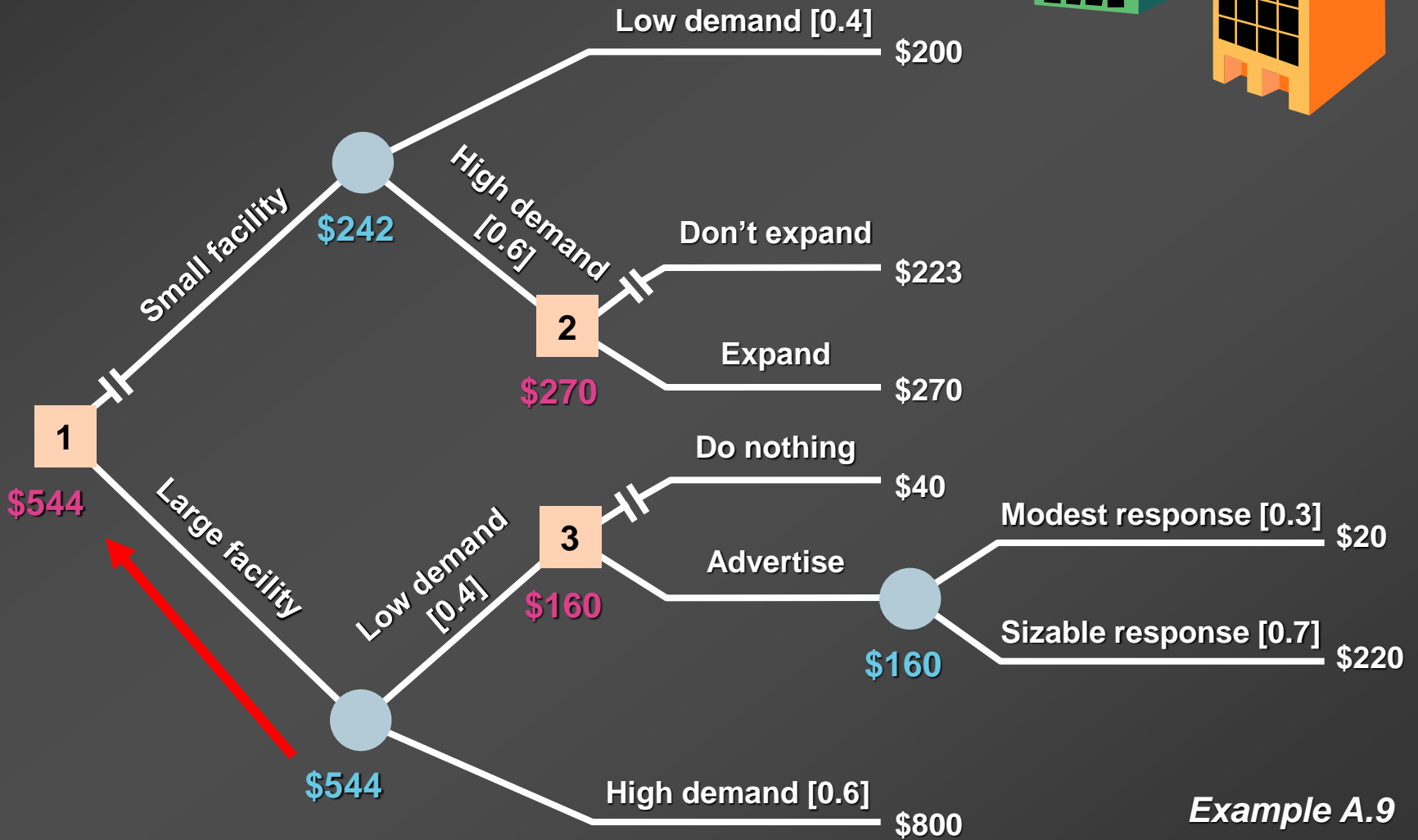
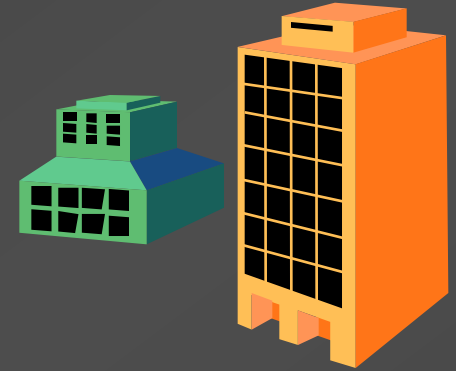

Example A.9

Decision Trees

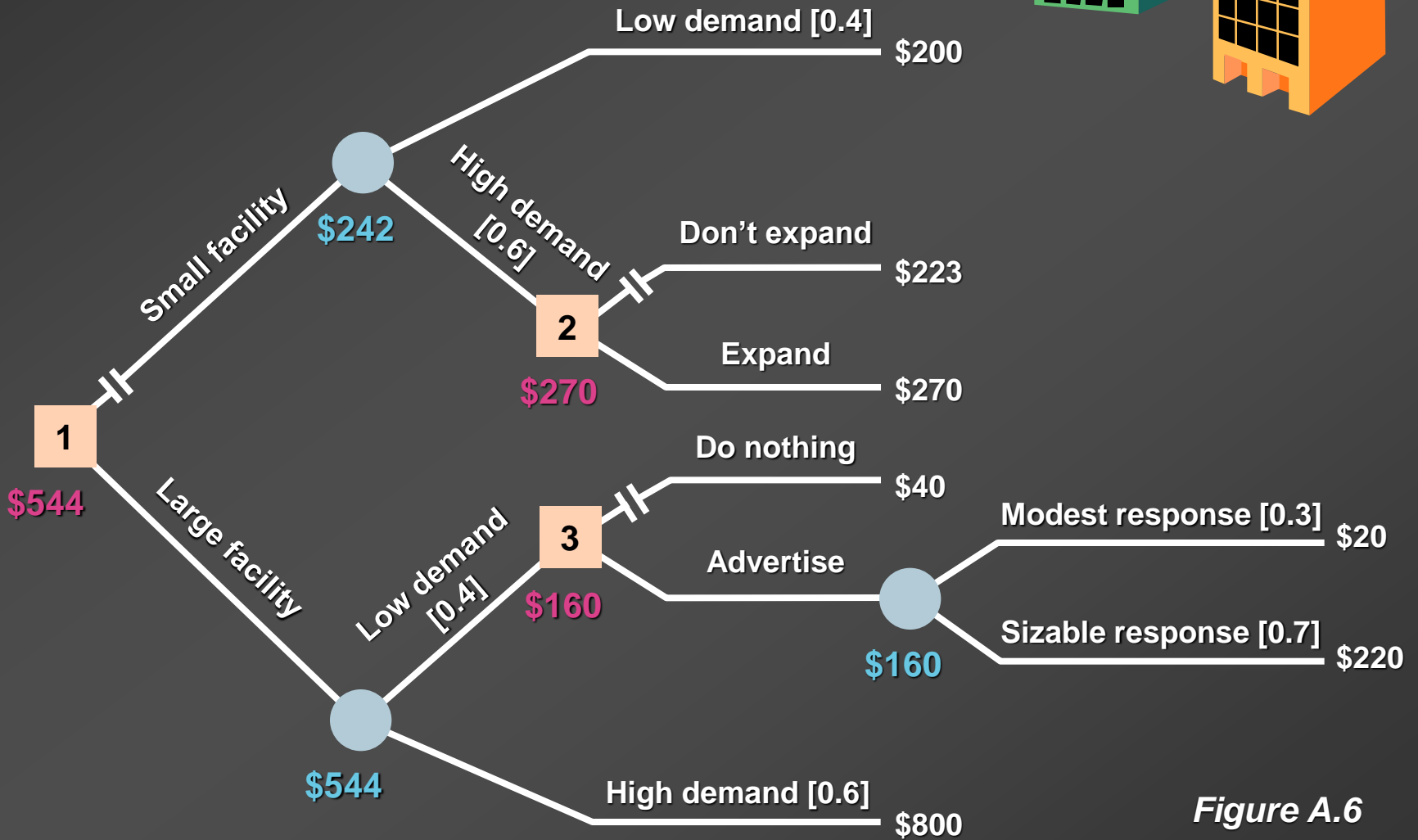
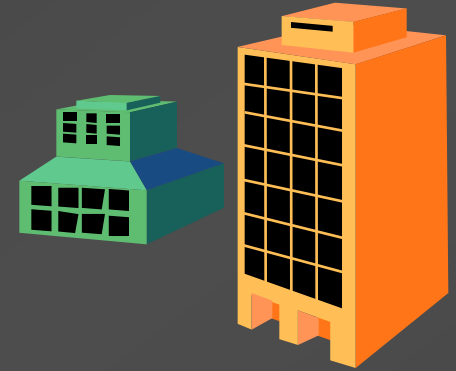

Figure A.6

NETWORK DESIGN DECISIONS

- *Introducing method*
 - *Fixed and variable cost*
 - *Identified forecasts*
 - *One product*
 - *Total cost is fixed cost + unit variable cost x Quantity*
 - *Example and identification of equivalence levels*
 - *Best choice is*

Fixed and variable cost

Site	Fixed cost	Variable cost
A	250 000 \$	11 \$ per unit
B	100 000 \$	30 \$ per unit
C	150 000 \$	20 \$ per unit
D	200 000 \$	35 \$ per unit

Site	Fixed cost	Variable cost ...	Total cost
A	250 000 \$	11x10 000 u	360 000 \$
B	100 000 \$	30x 10 000 u	400 000 \$
C	150 000 \$	20 x 10 000 u	350 000 \$
D	200 000 \$	35 x 10 000 u	550 000 \$

Let's come back to break even

$$100\,000 \$ + 30 \$ \times Q = 150\,000 \$ + 20 \$ \times Q \quad Q = 5000 \text{ u}$$

$$150\,000 \$ + 20 \$ \times Q = 250\,000 \$ + 11 \$ \times Q \quad Q = 11\,111 \text{ u}$$

$$100\,000 \$ + 30 \$ \times Q = 250\,000 \$ + 11 \$ \times Q \quad Q = 7\,895 \text{ u}$$

NETWORK DESIGN DECISIONS

- ***Transport cost***
 - *Impact*
 - *Finished goods flows*
 - *Raw materials*
 - *Multi choice to be solved through transport model*
- ***Weighing method***
 - *Relevant factors*
 - *Weighing*
- ***Gravity center method***
 - *Geographical coordinates*

Gravity center method

Coordinates of x,y

Average of x = Sum of x_i / n destinations

Average of y = sum of y_i / n destinations

Average of x,y will be optimum location

BUT

we have to take into account
quantities carried

- *Average of x becomes*
sum of $x_i \cdot Q_i$ / sum Q_i
- *Average of y becomes*
sum of $y_i \cdot Q_i$ / sum Q_i

NETWORK DESIGN DECISIONS

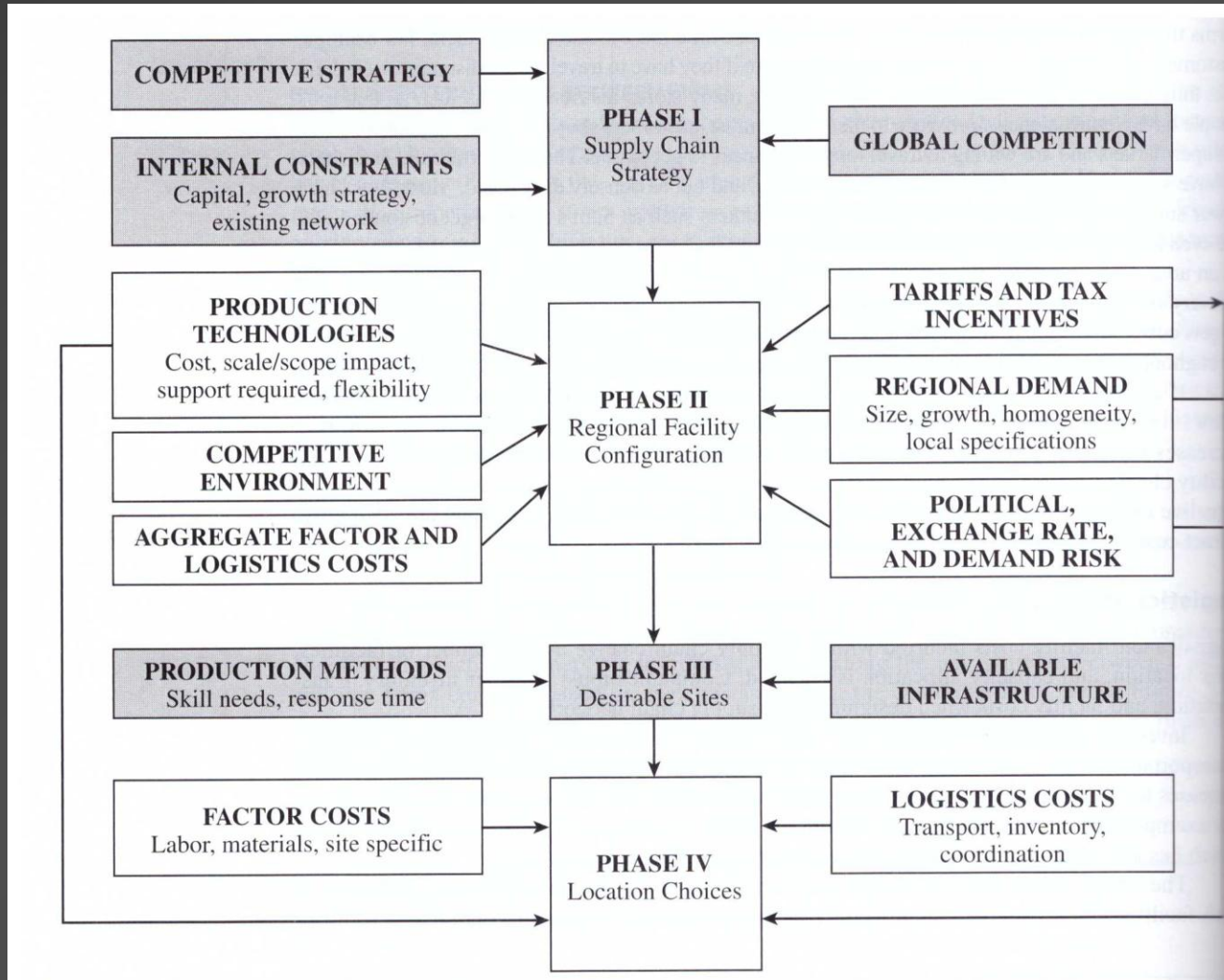

Planning and Managing Projects

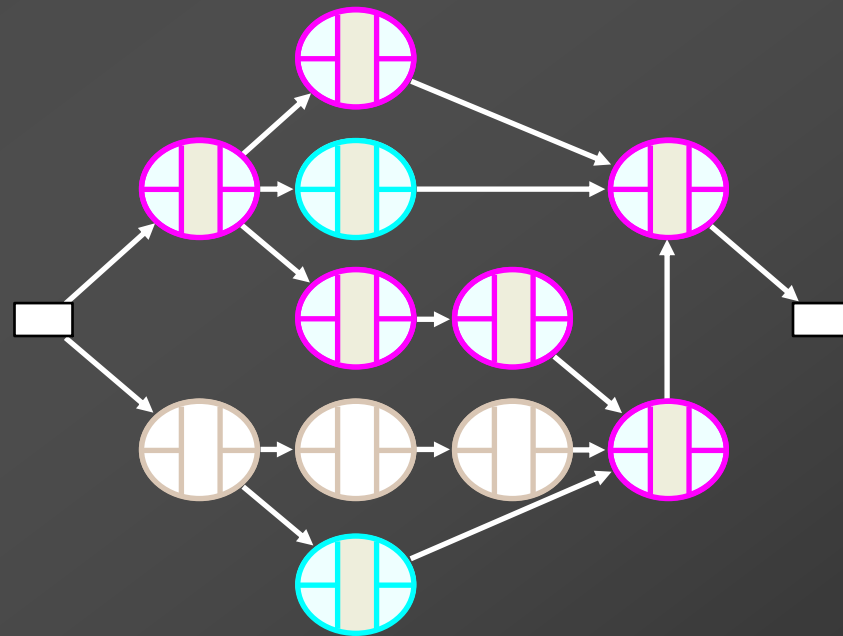

Activity Relationships

Activity Relationship

AOA	AON

Activity on Arc

Activity on Network

Activity Relationships

Activity Relationship

S precedes T, which precedes U.

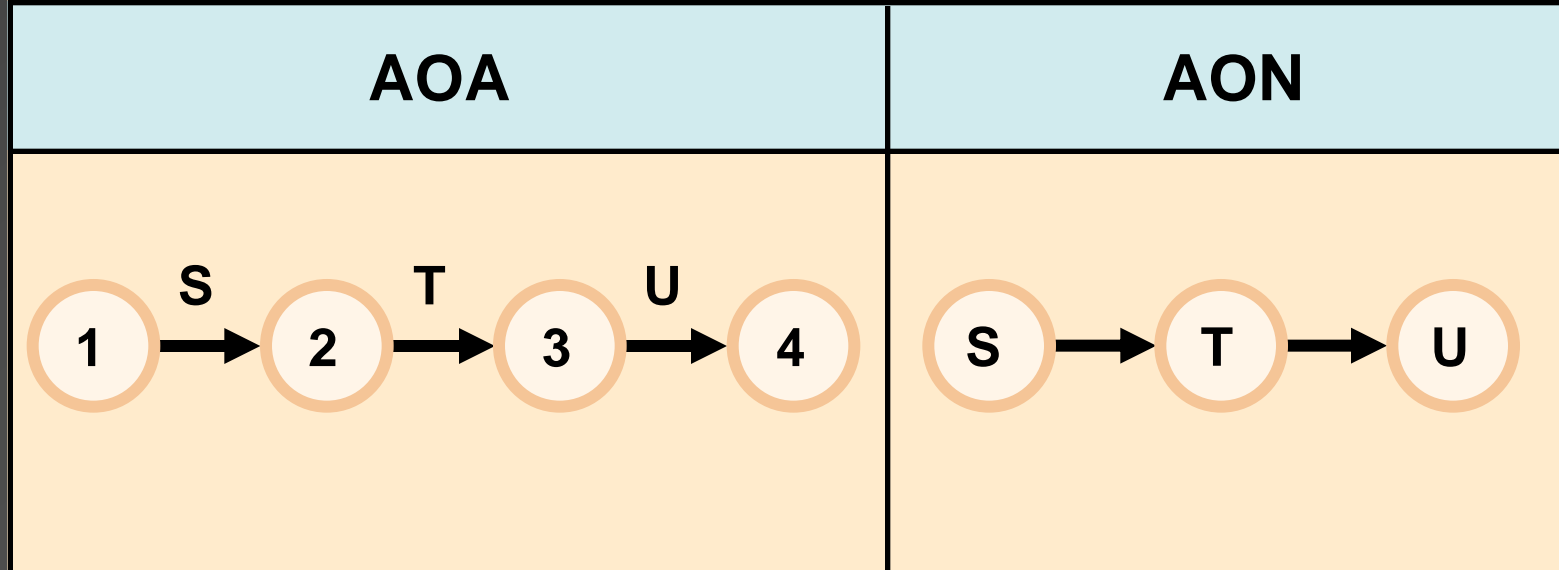

Activity on Arc

Activity on Network

Activity Relationships

Activity Relationship

S and T must be completed before U can be started.

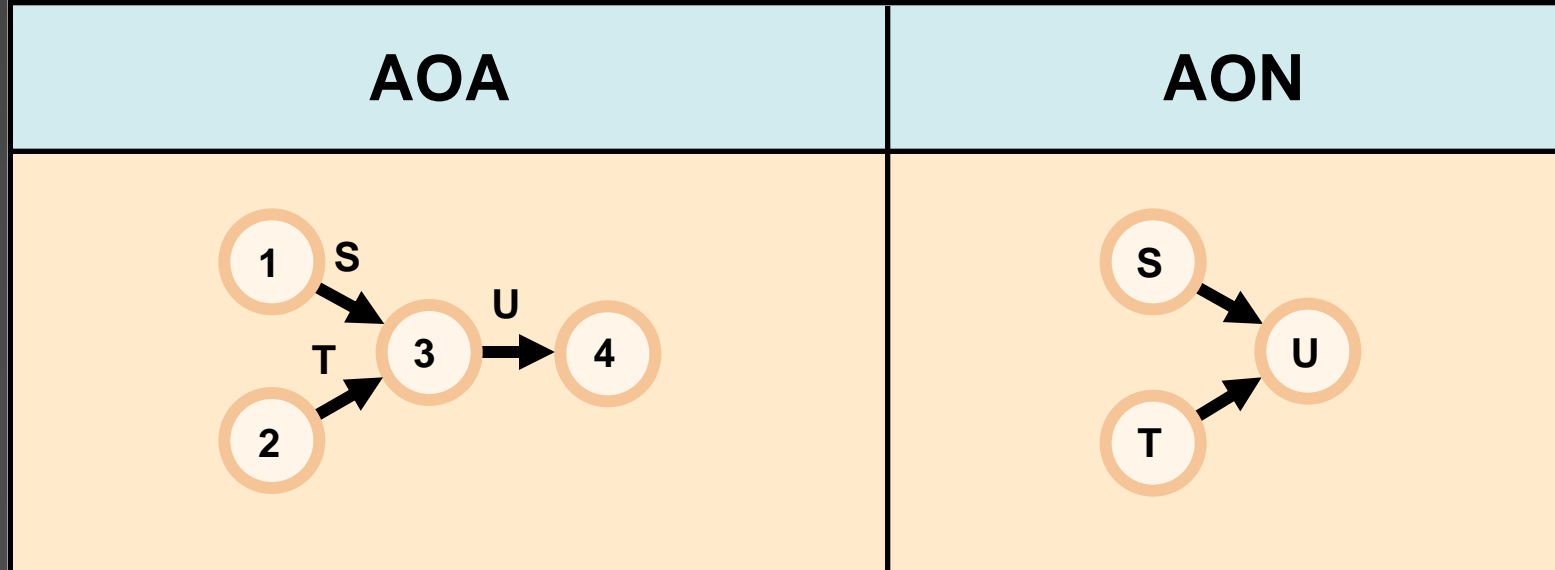

Activity Relationships

Activity Relationship

T and U cannot begin until S has been completed.

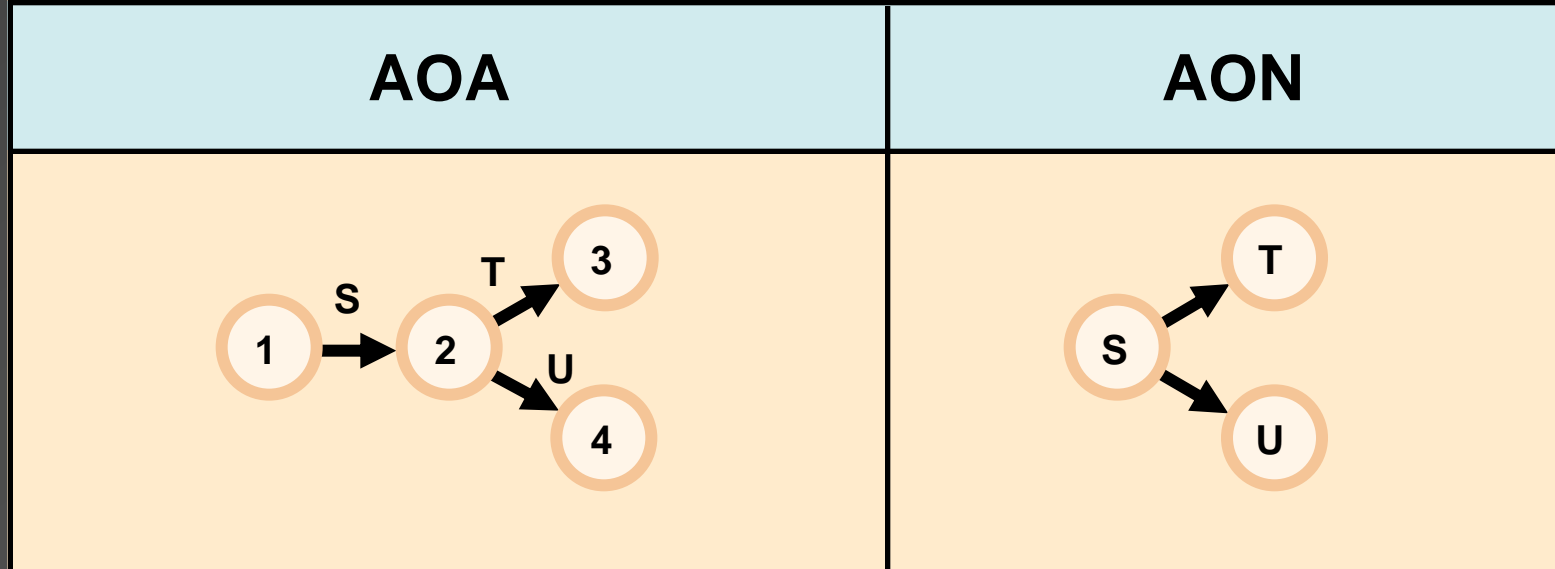

Activity Relationships

Activity Relationship

U and V cannot begin until both S and T have been completed.

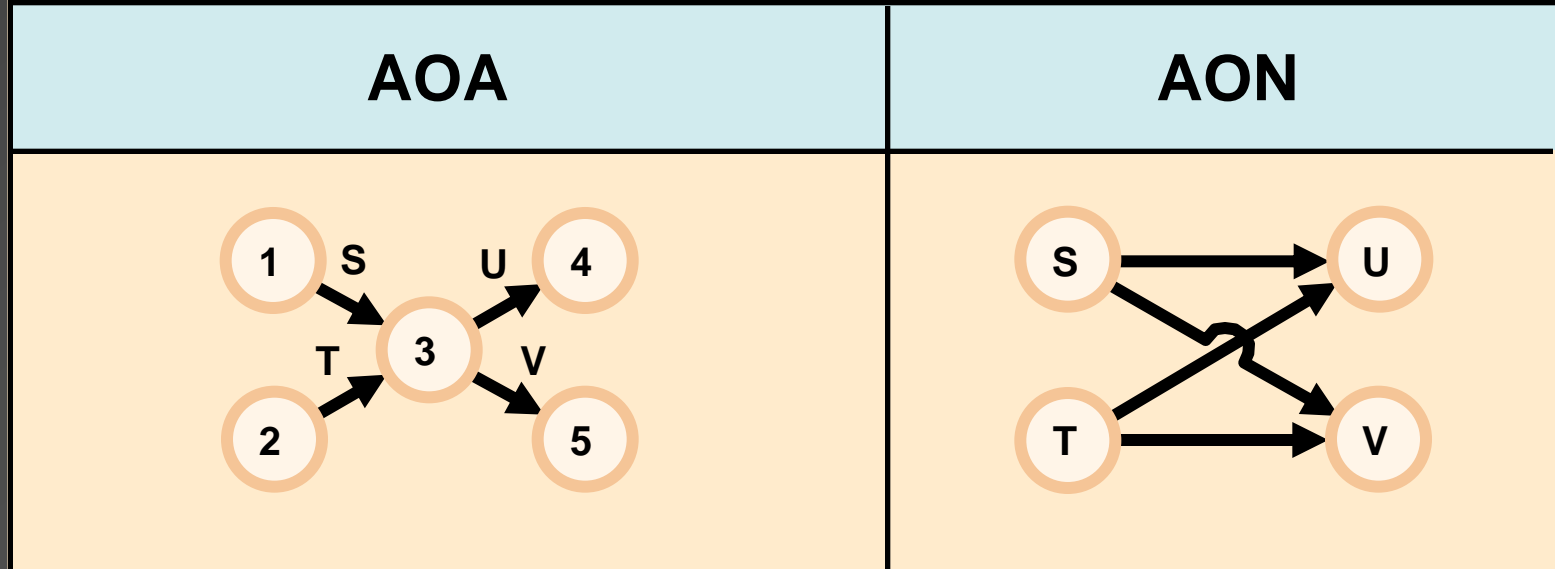

Activity Relationships

Activity Relationship

*U cannot begin until both S and T have been completed;
V cannot begin until T has been completed.*

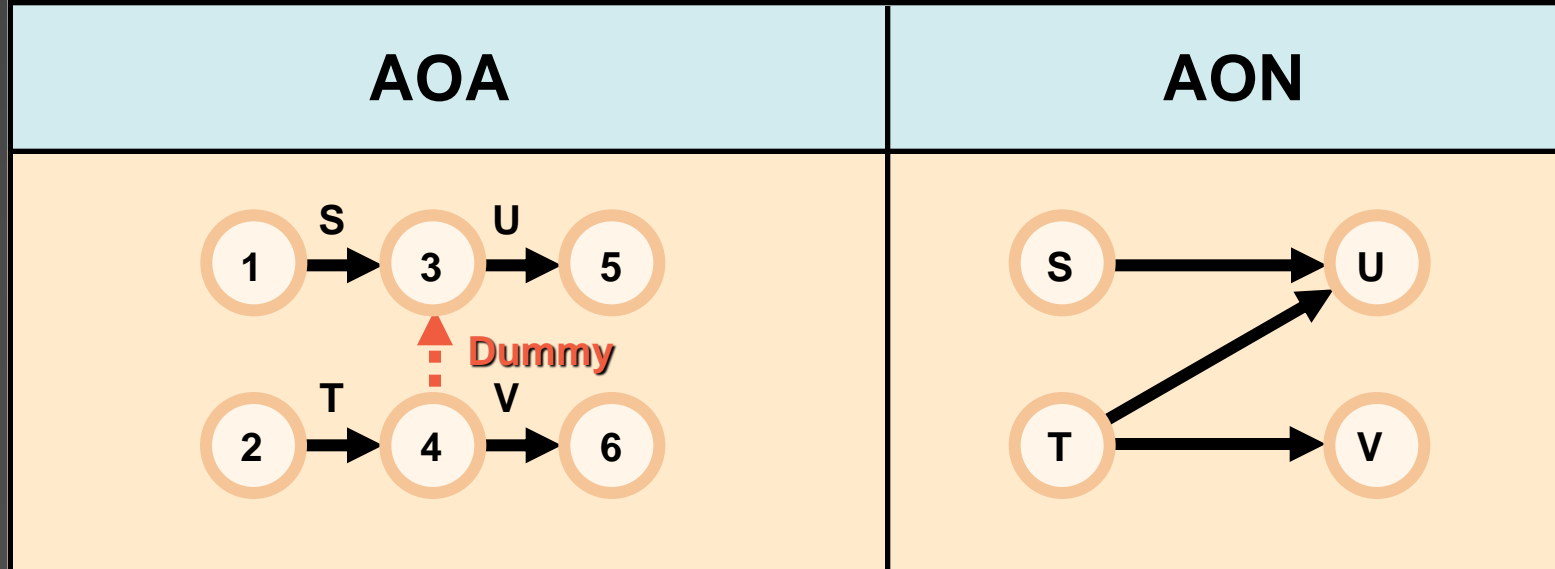

Activity Relationships

Activity Relationship

T and U cannot begin until S has been completed; V cannot begin until both T and U have been completed.

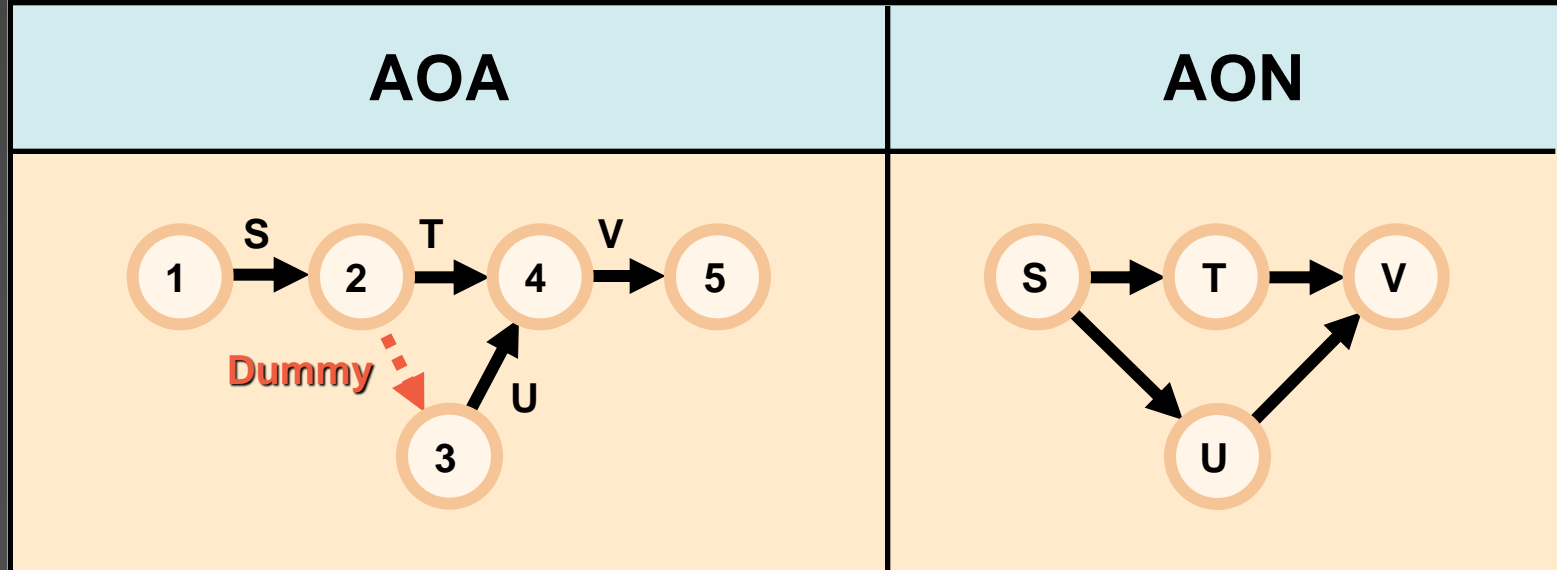

Figure 8.3

St. Adolf's Hospital



St. Adolf's Hospital



Activity	Description	Immediate Predecessor(s)	Responsibility
A	Select administrative and medical staff.		
B	Select site and do site survey.		
C	Select equipment.		
D	Prepare final construction plans and layout.		
E	Bring utilities to the site.		
F	Interview applicants and fill positions in nursing, support staff, maintenance, and security.		
G	Purchase and take delivery of equipment.		
H	Construct the hospital.		
I	Develop an information system.		
J	Install the equipment.		
K	Train nurses and support staff.		

Example 8.1

St. Adolf's Hospital



Activity	Description	Immediate Predecessor(s)	Responsibility
A	Select administrative and medical staff.	—	Johnson
B	Select site and do site survey.	—	Taylor
C	Select equipment.	A	Adams
D	Prepare final construction plans and layout.	B	Taylor
E	Bring utilities to the site.	B	Burton
F	Interview applicants and fill positions in nursing, support staff, maintenance, and security.	A	Johnson
G	Purchase and take delivery of equipment.	C	Adams
H	Construct the hospital.	D	Taylor
I	Develop an information system.	A	Simmons
J	Install the equipment.	E,G,H	Adams
K	Train nurses and support staff.	F,I,J	Johnson

St. Adolf's Hospital

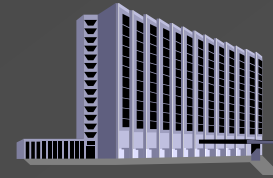

AON Network

Responsibility

Johnson
Director
Programs
Director
Director
Johnson

Programs
Director
Programs
Programs
Johnson

St. Adolf's Hospital

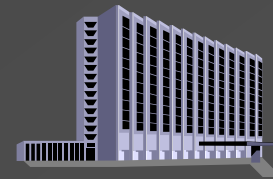

AON Network

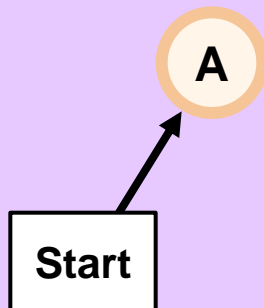

responsibility

nson
lor
ams
lor
ton
nson

ams
lor
mons
ams
nson

St. Adolf's Hospital

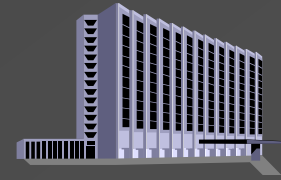

AON Network

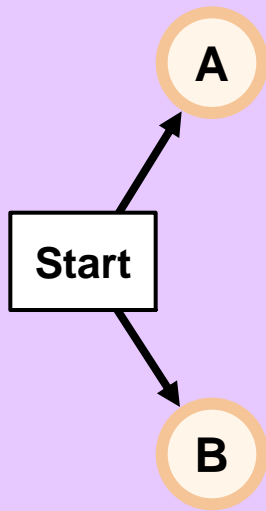

responsibility

nson
lor
ams
lor
ton
nson

ams
lor
mons
ams
nson

St. Adolf's Hospital

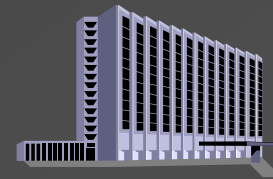

AON Network

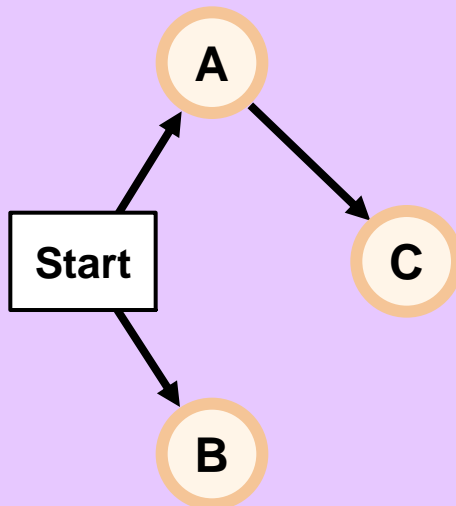

responsibility

nson
lor
ams
lor
ton
nson

ams
lor
mons
ams
nson

St. Adolf's Hospital



AON Network

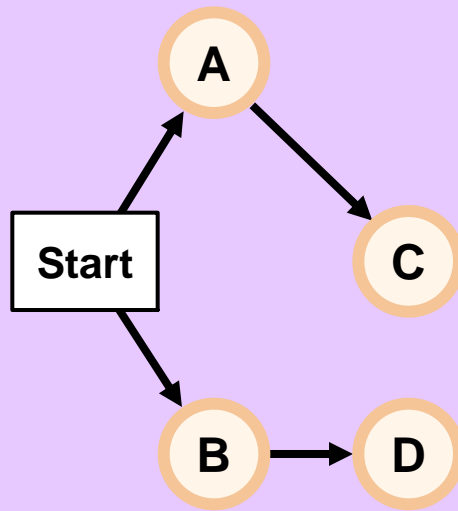

responsibility

nson
lor
ams
lor
ton
nson

ams
lor
mons
ams
nson



St. Adolf's Hospital

AON Network

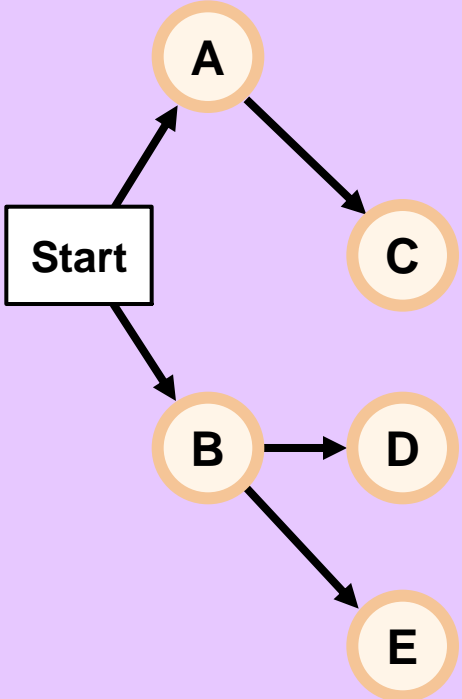

responsibility

anson
lor
ams
lor
ton
anson

ams
lor
mons
ams
anson



St. Adolf's Hospital

AON Network

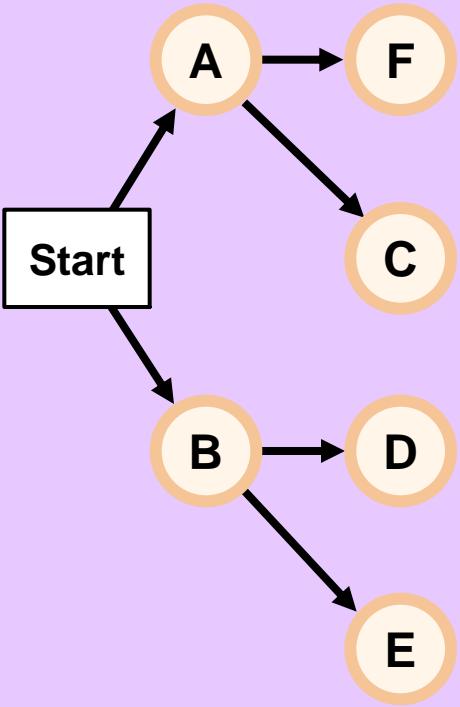

responsibility

anson
lor
ams
lor
ton
anson

ams
lor
mons
ams
anson



St. Adolf's Hospital

AON Network

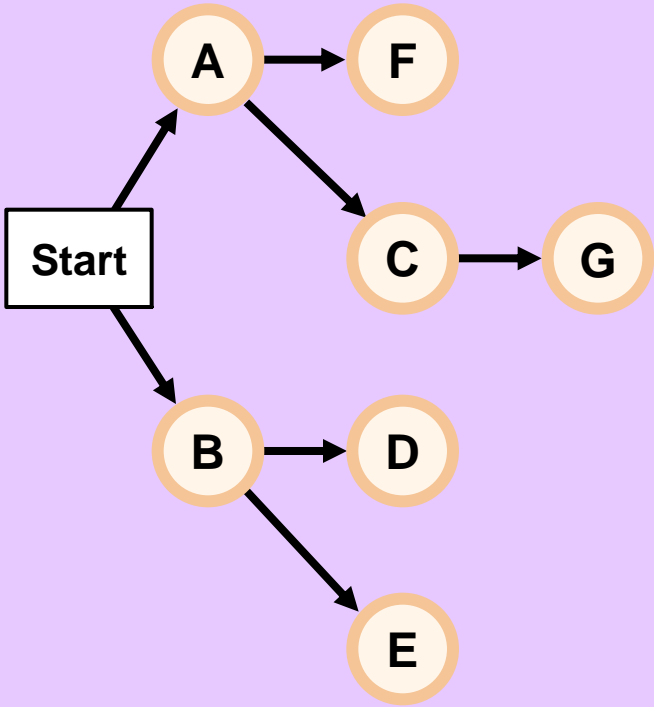

responsibility

nson
lor
ams
lor
ton
nson

ams
lor
mons
ams
nson



St. Adolf's Hospital

AON Network

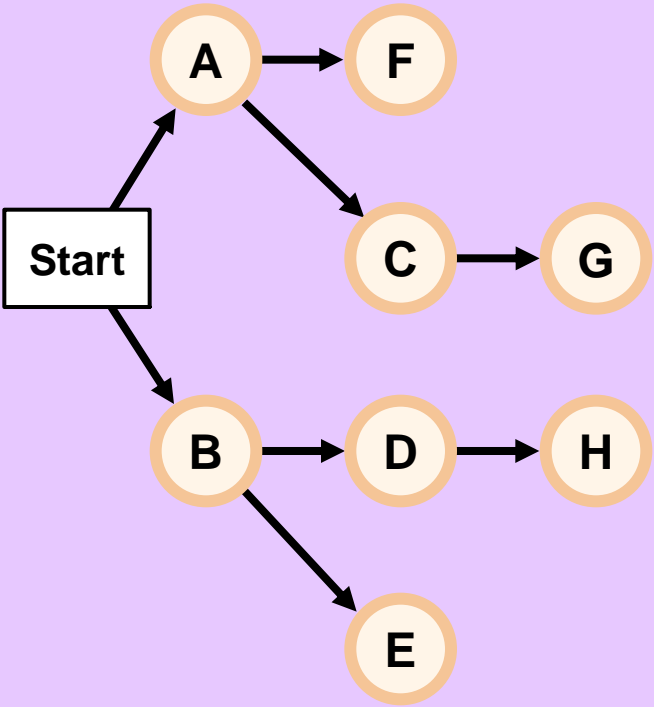

responsibility

nson
lor
ams
lor
ton
nson

ams
lor
mons
ams
nson

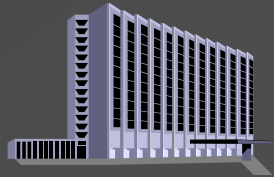

St. Adolf's Hospital

AON Network

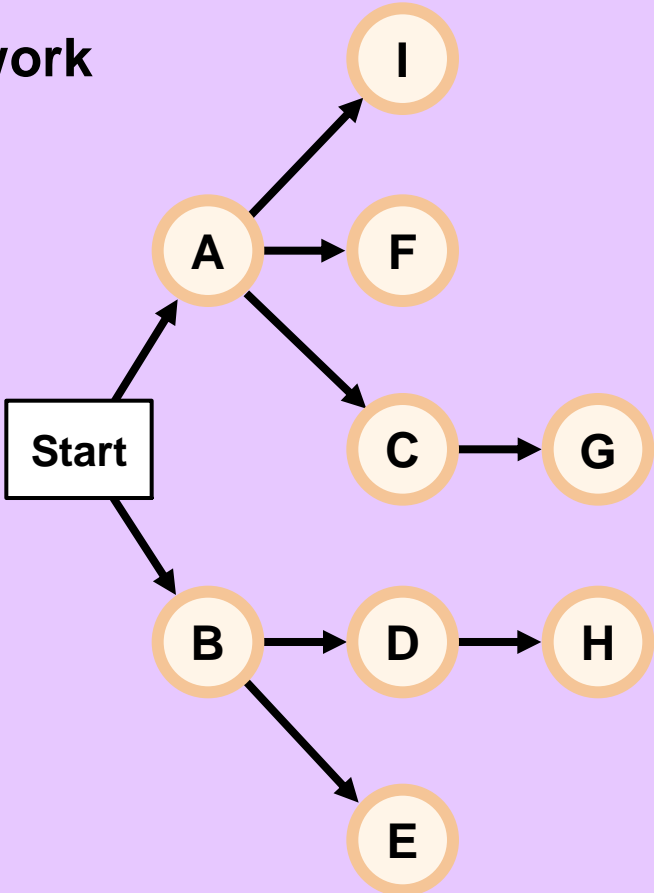

responsibility

anson
lor
ams
lor
ton
anson

ams
lor
mons
ams
anson

St. Adolf's Hospital

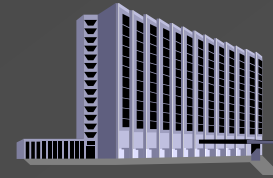

AON Network

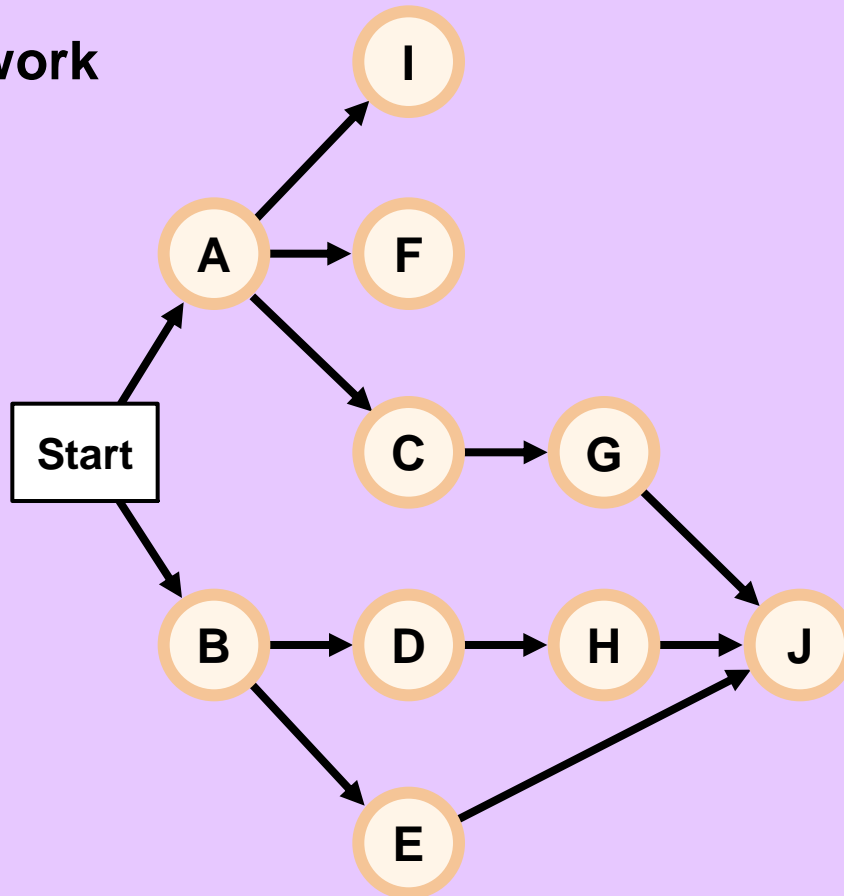

responsibility

nson
lor
ams
lor
ton
nson

ams
lor
mons
ams
nson

St. Adolf's Hospital

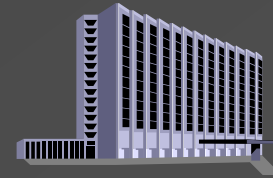

AON Network

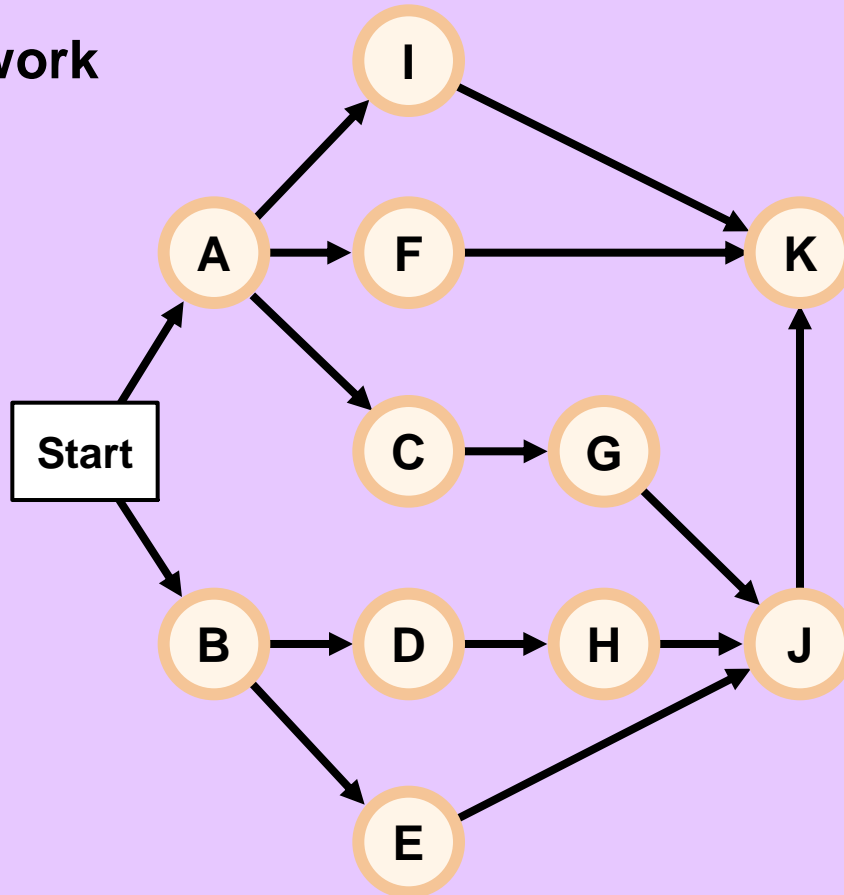

responsibility

anson
lor
ams
lor
ton
anson

ams
lor
mons
ams
anson



St. Adolf's Hospital

AON Network

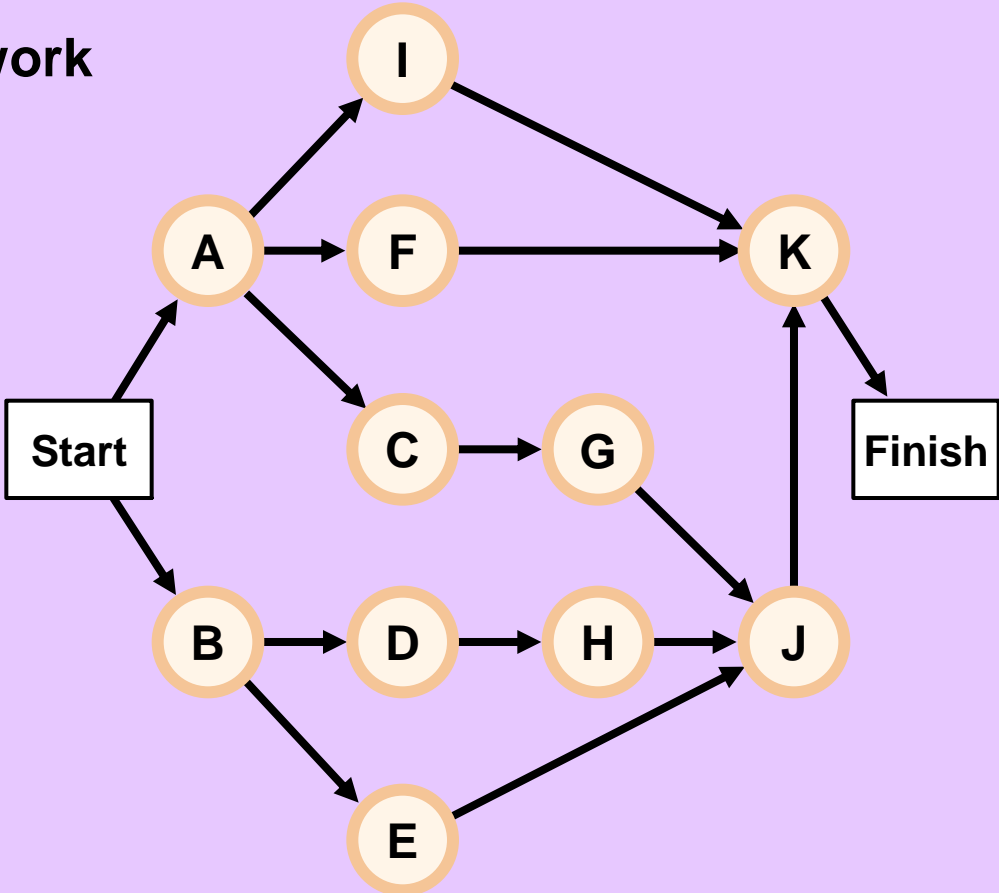

responsibility

anson
lor
ams
lor
ton
anson

ams
lor
mons
ams
anson

St. Adolf's Hospital

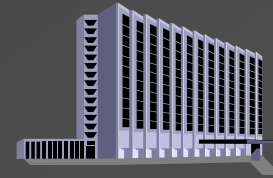

AOA Network

Responsibility

son
lor
ams
lor
ton
nson

ams
lor
mons
ams
nson

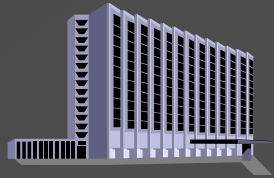

St. Adolf's Hospital

AOA Network

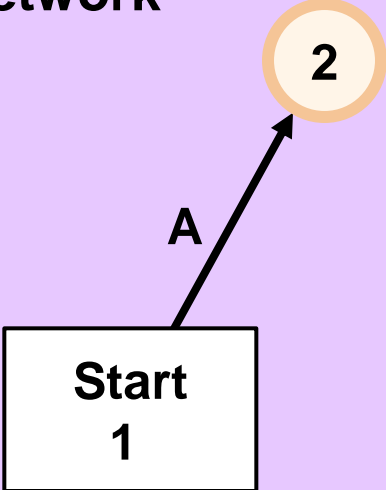

Responsibility

Johnson
Director
Systems
Director
Operations
Johnson

Systems
Director
Operations
Systems
Johnson



St. Adolf's Hospital

AOA Network

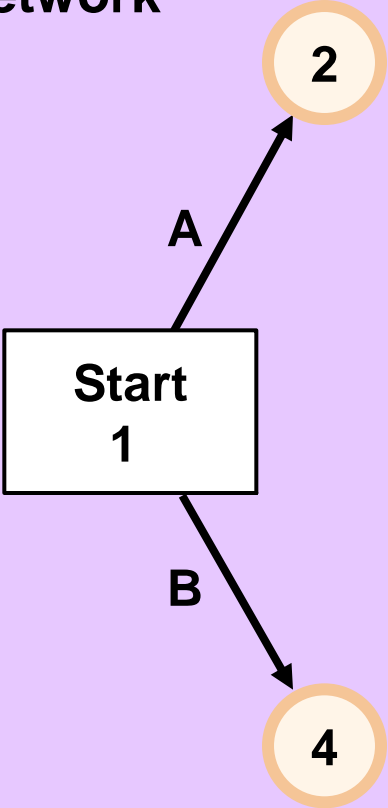

Responsibility

Johnson
Director
Systems
Director
Department
Johnson

Systems
Director
Systems
Systems
Johnson



St. Adolf's Hospital

AOA Network

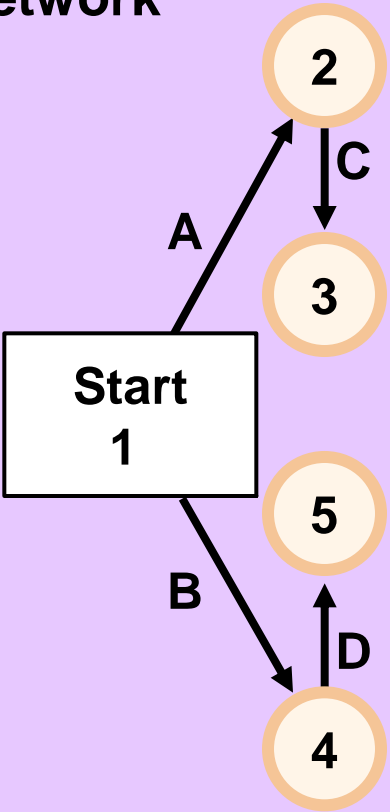

responsibility

anson
lor
ams
lor
ton
anson

ams
lor
mons
ams
anson

St. Adolf's Hospital



AOA Network

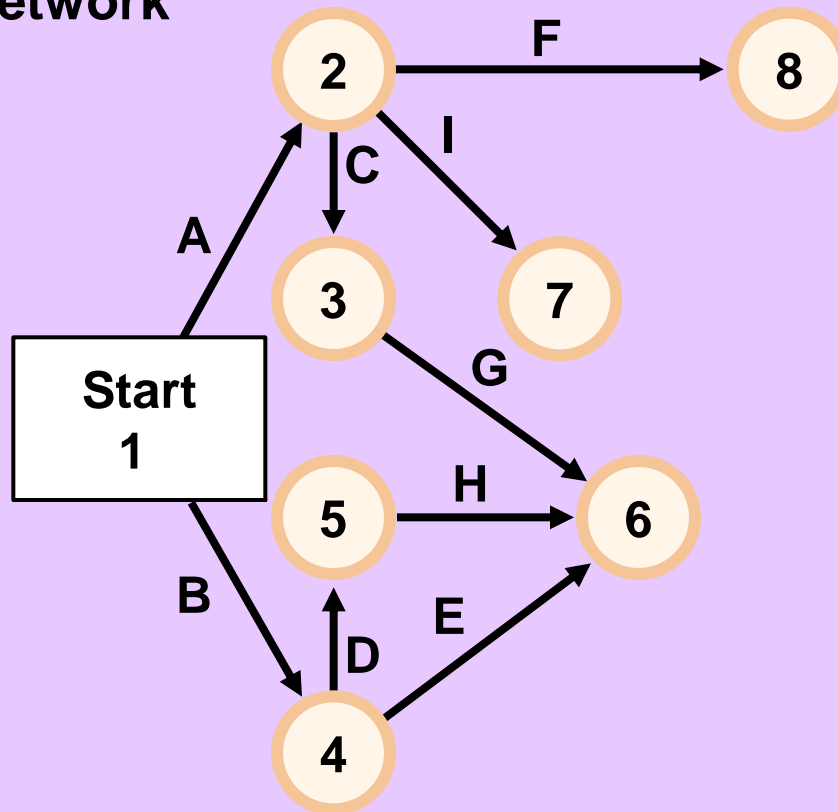

responsibility

anson
lor
ams
lor
ton
anson

ams
lor
mons
ams
anson

St. Adolf's Hospital



AOA Network

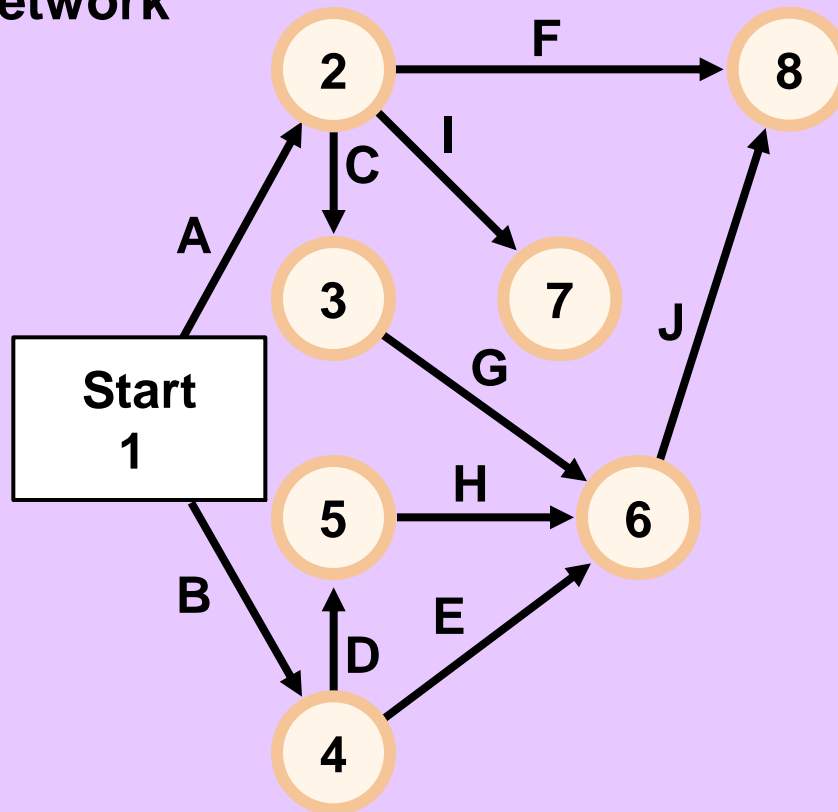

responsibility

anson
lor
ams
lor
ton
anson

ams
lor
mons
ams
anson

St. Adolf's Hospital

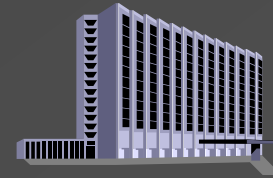

AOA Network

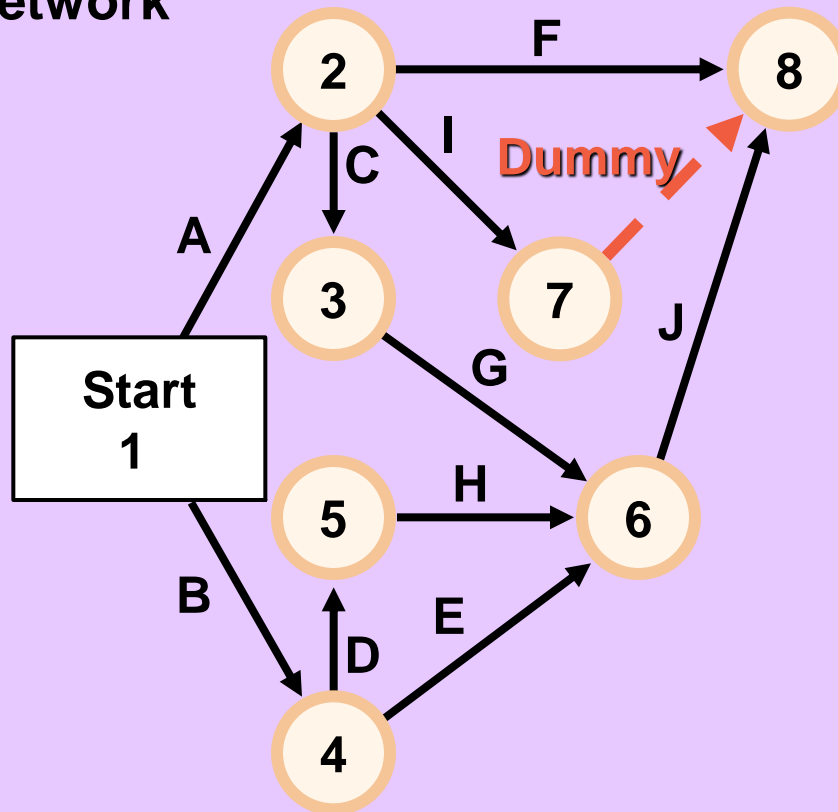

responsibility

anson
lor
ams
lor
ton
anson

ams
lor
mons
ams
anson

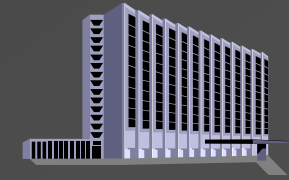

St. Adolf's Hospital

AOA Network

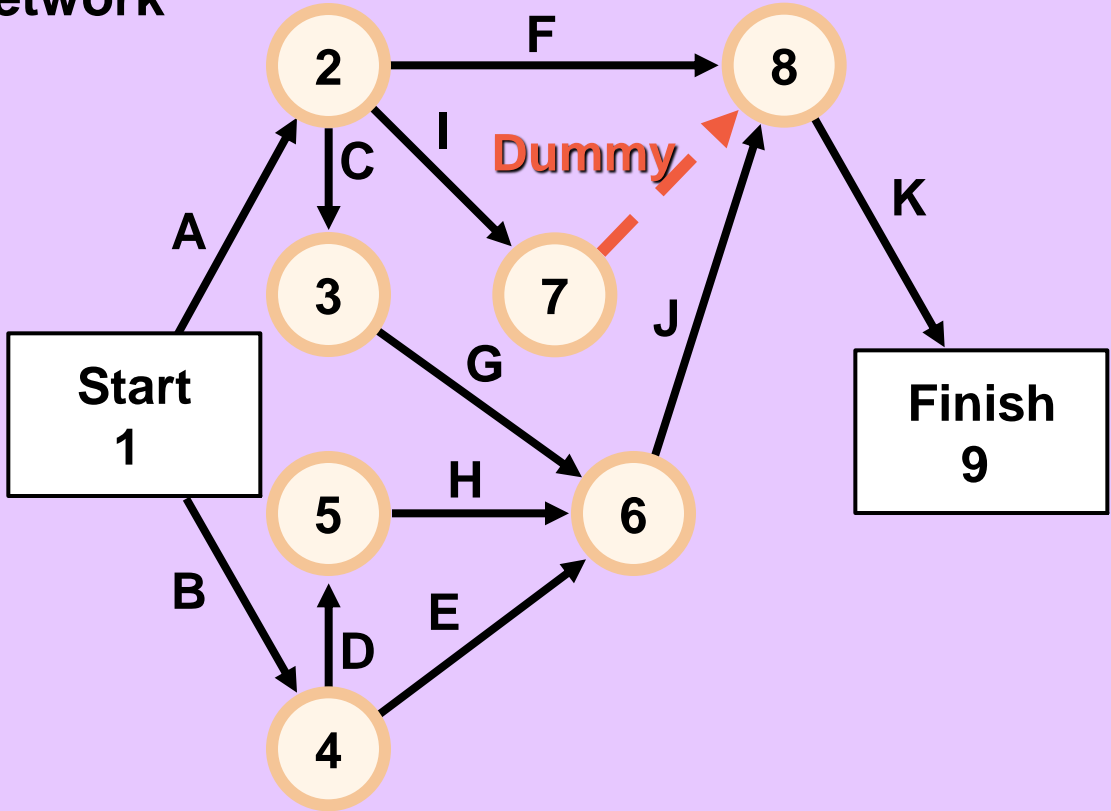

responsibility

anson
lor
ams
lor
ton
anson

ams
lor
mons
ams
anson

St. Adolf's Hospital

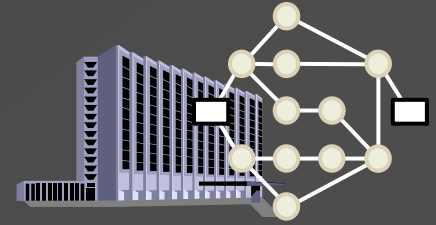

Completion Time

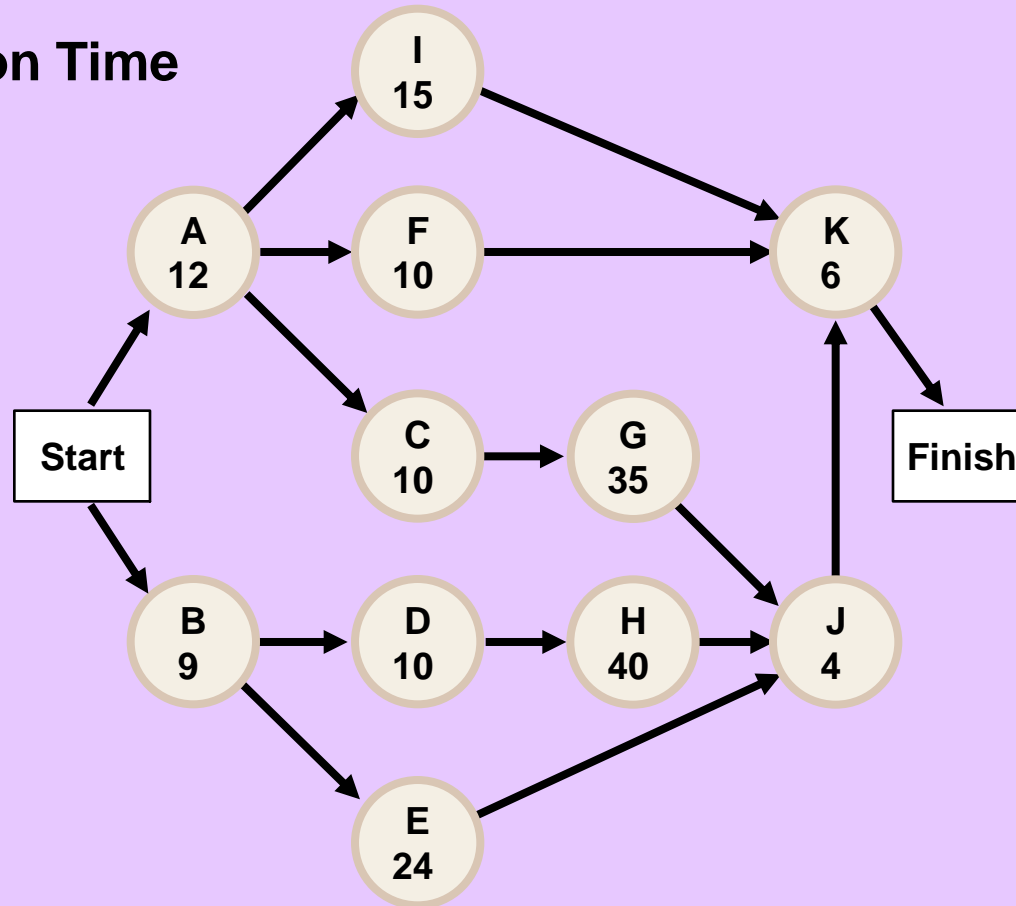

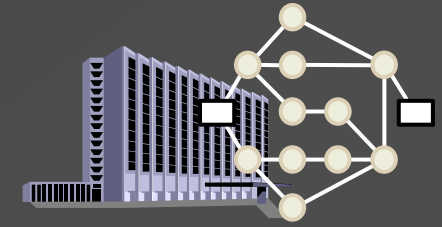

St. Adolf's Hospital

Completion Time

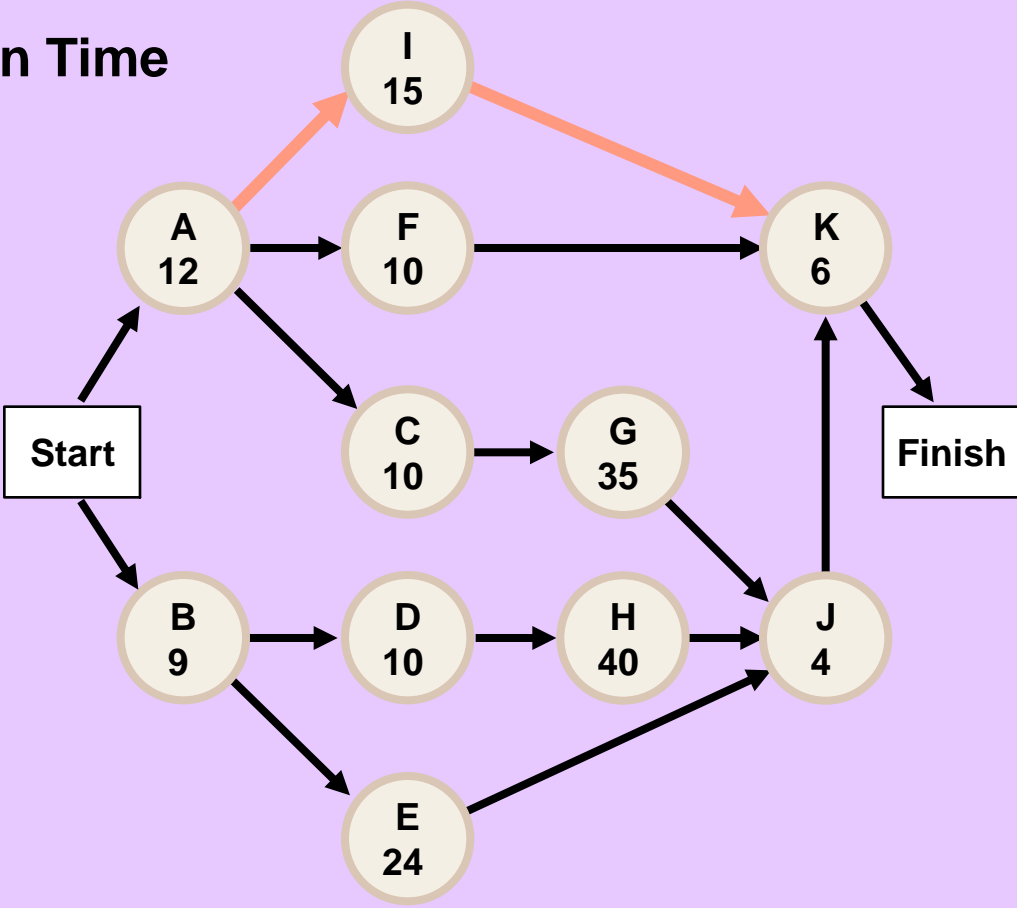

responsibility

anson
lor
ams
lor
ton
anson

ams
lor
mons
ams
anson

St. Adolf's Hospital

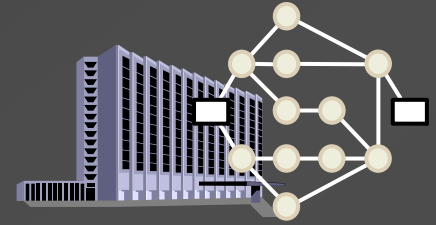

Completion Time

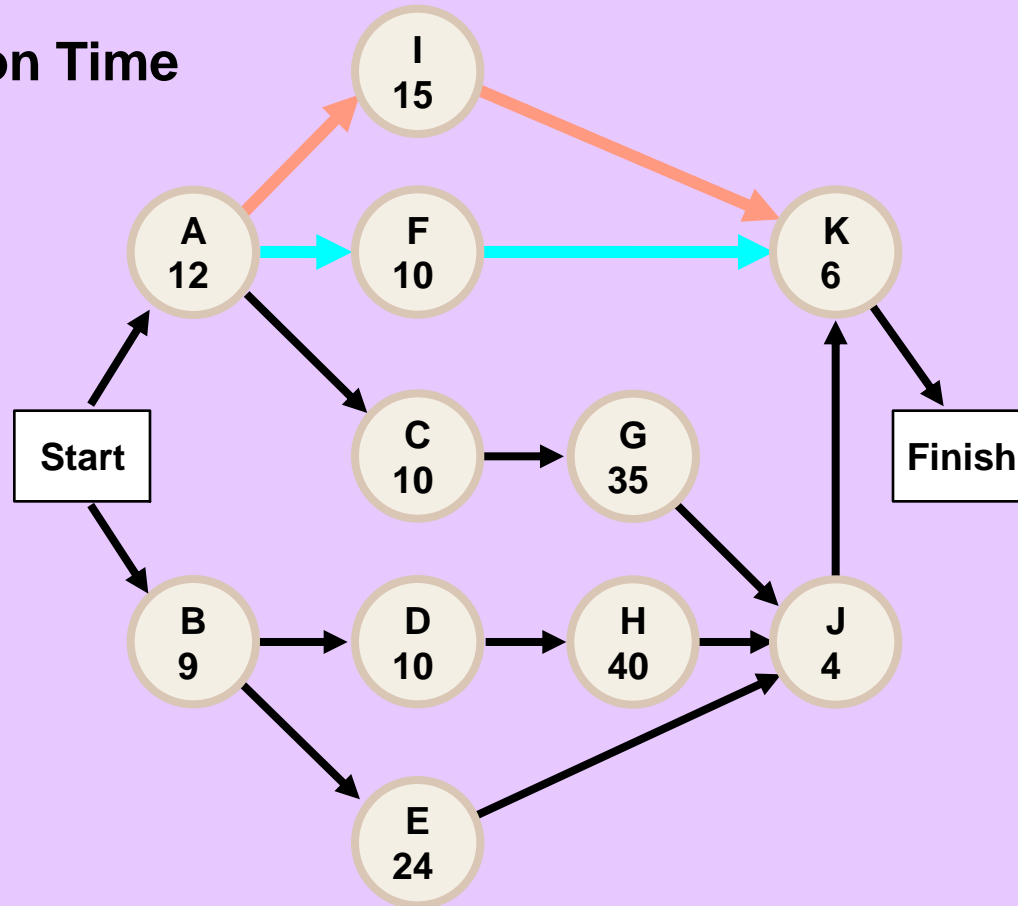

Responsibility

Johnson
Lor
ams
lor
ton
nson

ams
lor
mons
ams
nson

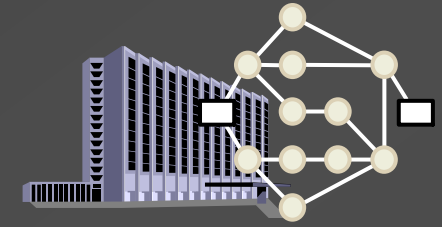

St. Adolf's Hospital

Completion Time

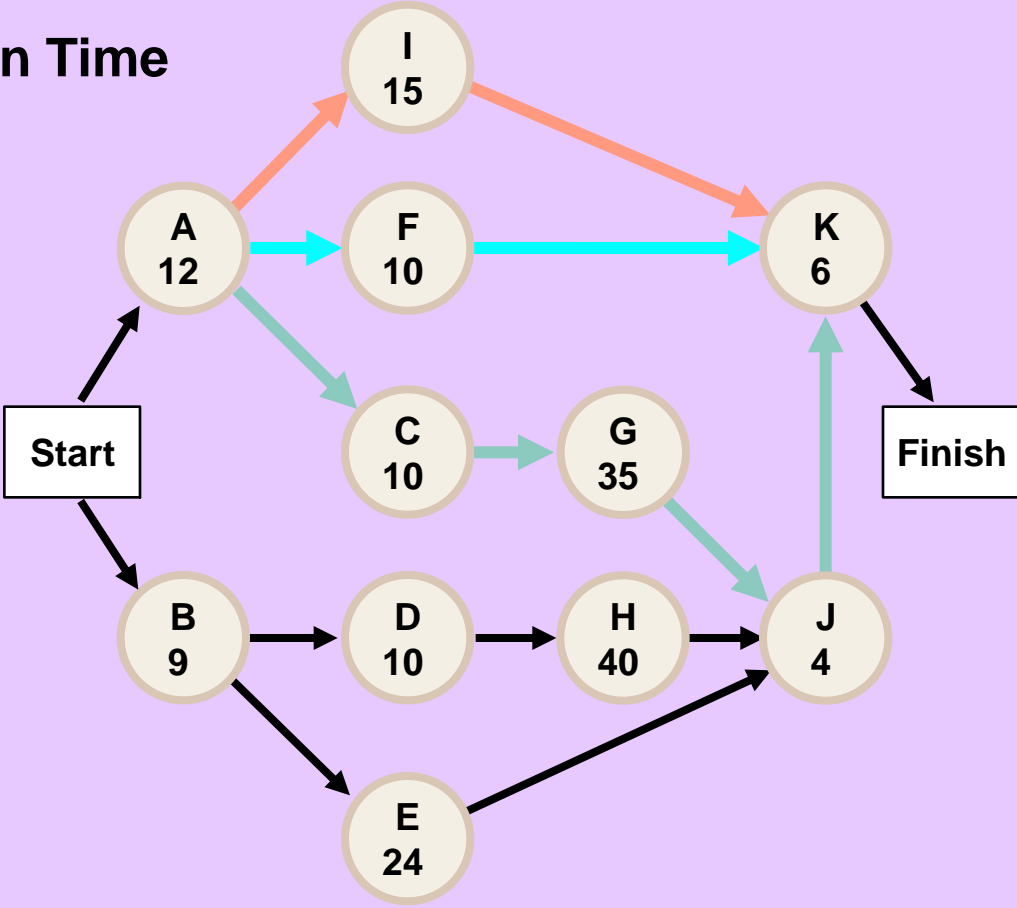

responsibility

anson
lor
ams
lor
ton
anson

ams
lor
mons
ams
anson

St. Adolf's Hospital

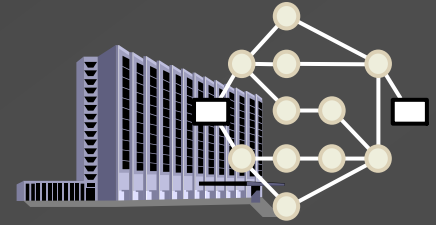

Completion Time

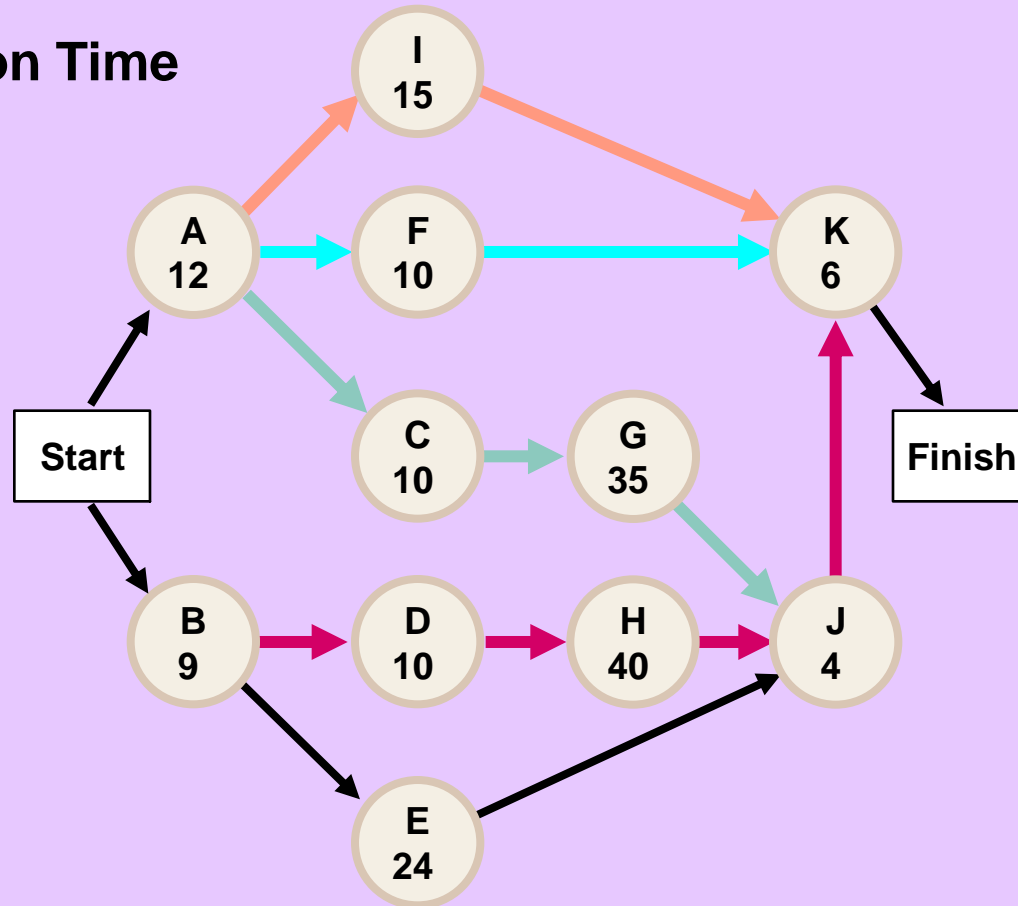

responsibility

anson
lor
ams
lor
ton
anson

ams
lor
mons
ams
anson

St. Adolf's Hospital

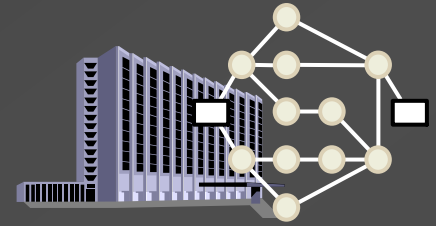

Completion Time

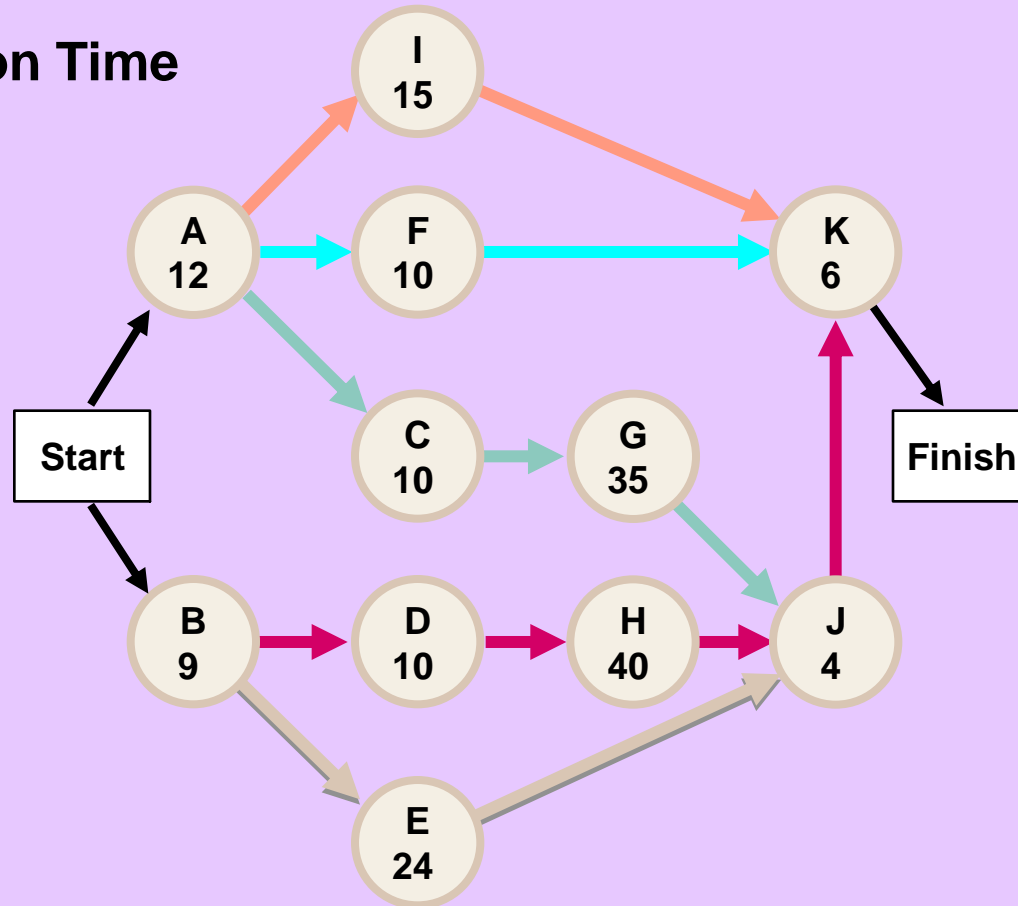

Responsibility

son
lor
ams
lor
ton
nson

ams
lor
mons
ams
nson

St. Adolf's Hospital

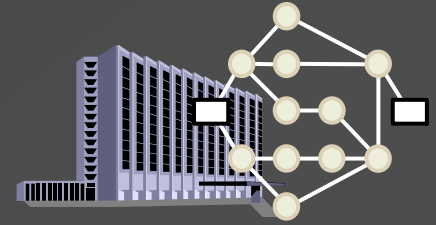

Path	Expected Time (wks)
A-F-K	28
A-I-K	33
A-C-G-J-K	67
B-D-H-J-K	69
B-E-J-K	43

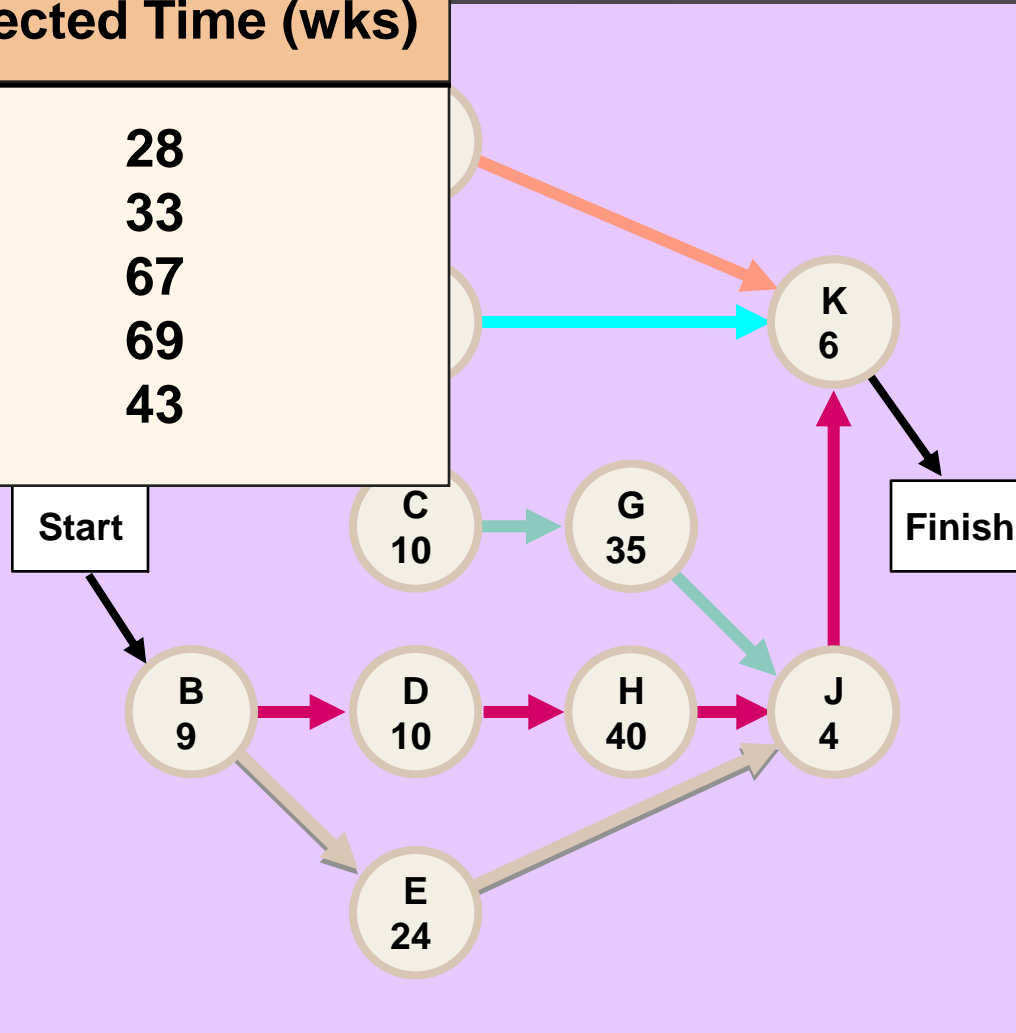

responsibility

anson
lor
ams
lor
ton
nson

ams
lor
mons
ams
nson

St. Adolf's Hospital

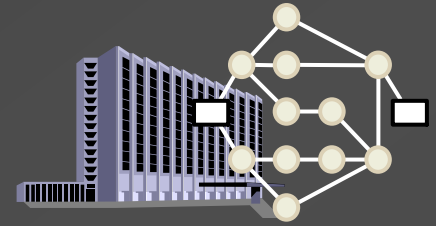

Path	Expected Time (wks)
A-F-K	28
A-I-K	33
A-C-G-I-K	67
B-D-H-J-K	69
B-E-J-K	43

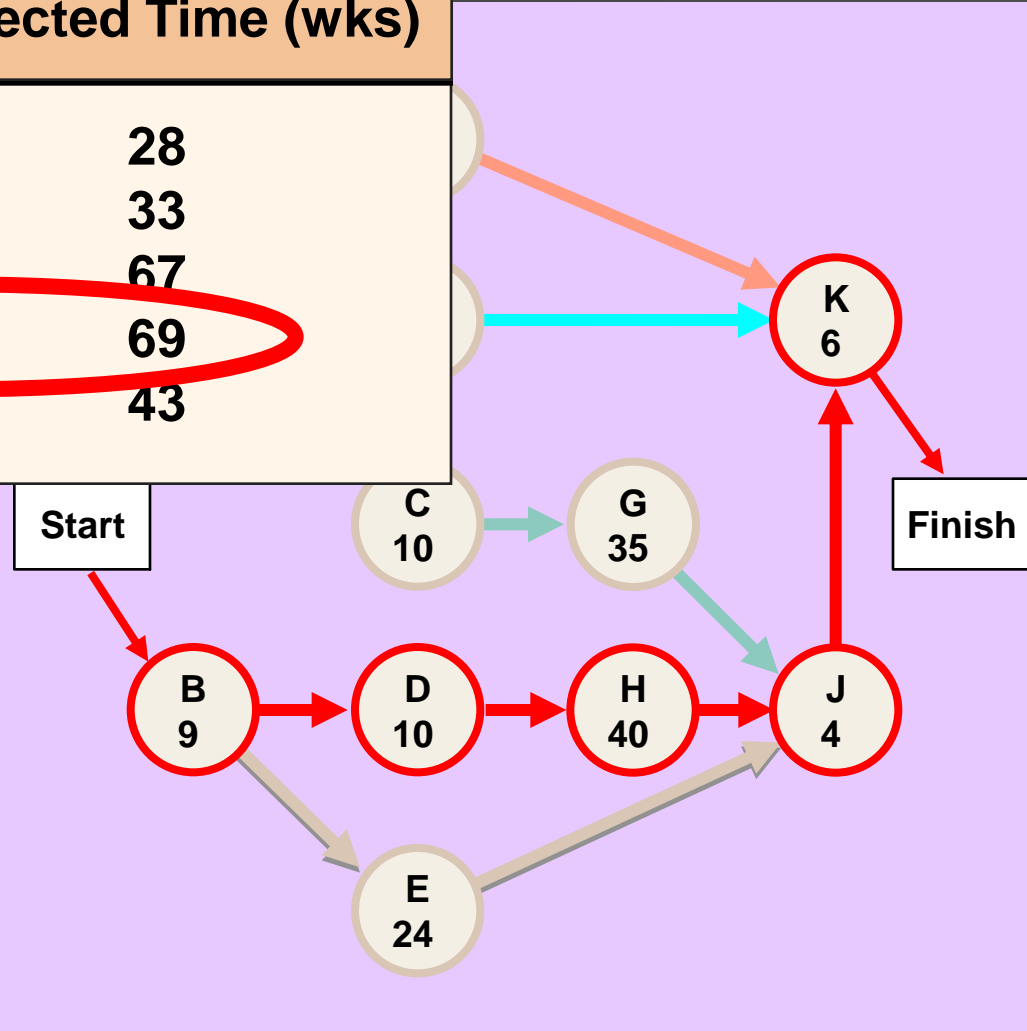

responsibility

anson
lor
ams
lor
ton
anson

ams
lor
mons
ams
anson

St. Adolf's Hospital

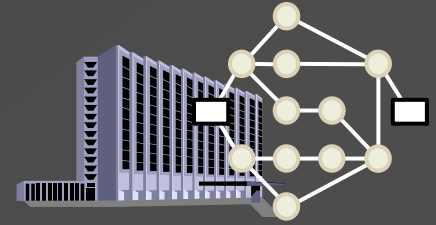

Completion Time

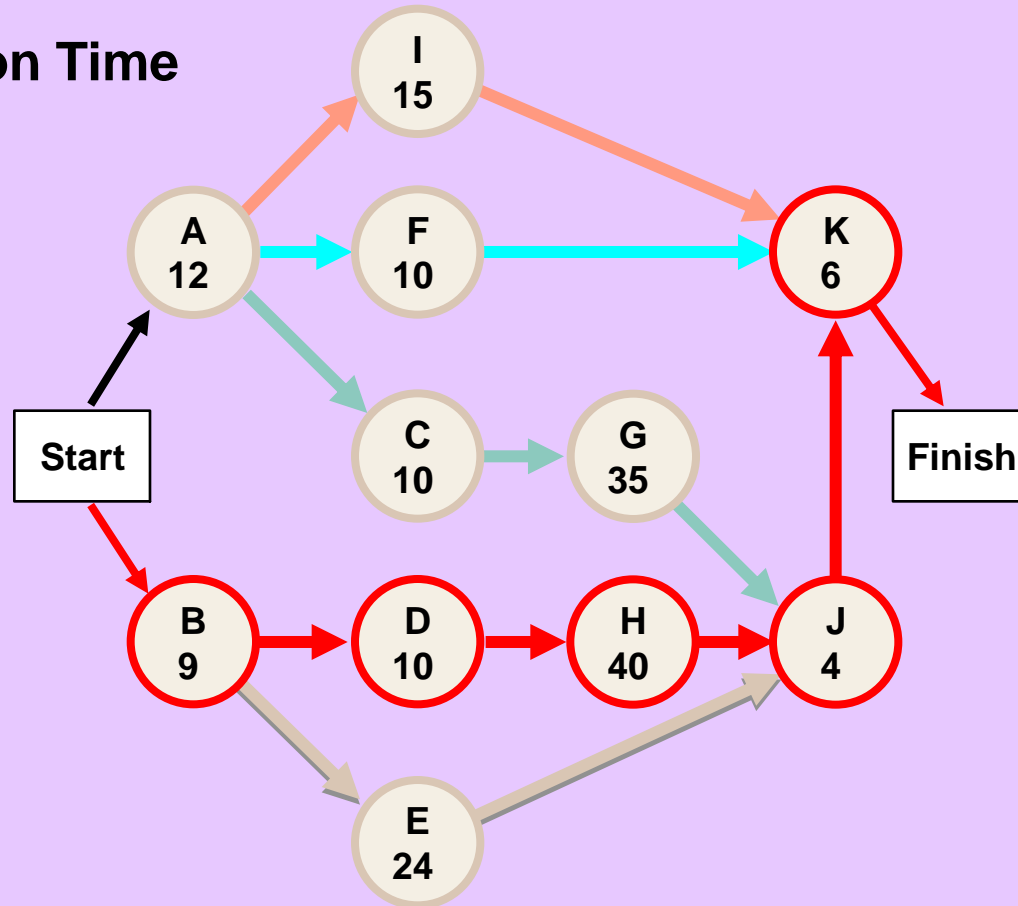

responsibility

anson
lor
ams
lor
ton
anson

ams
lor
mons
ams
anson

St. Adolf's Hospital

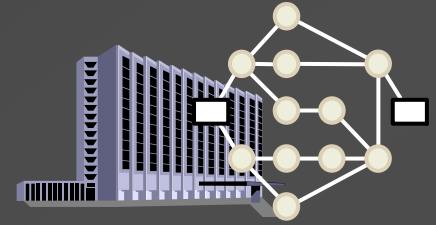

St. Adolf's Hospital

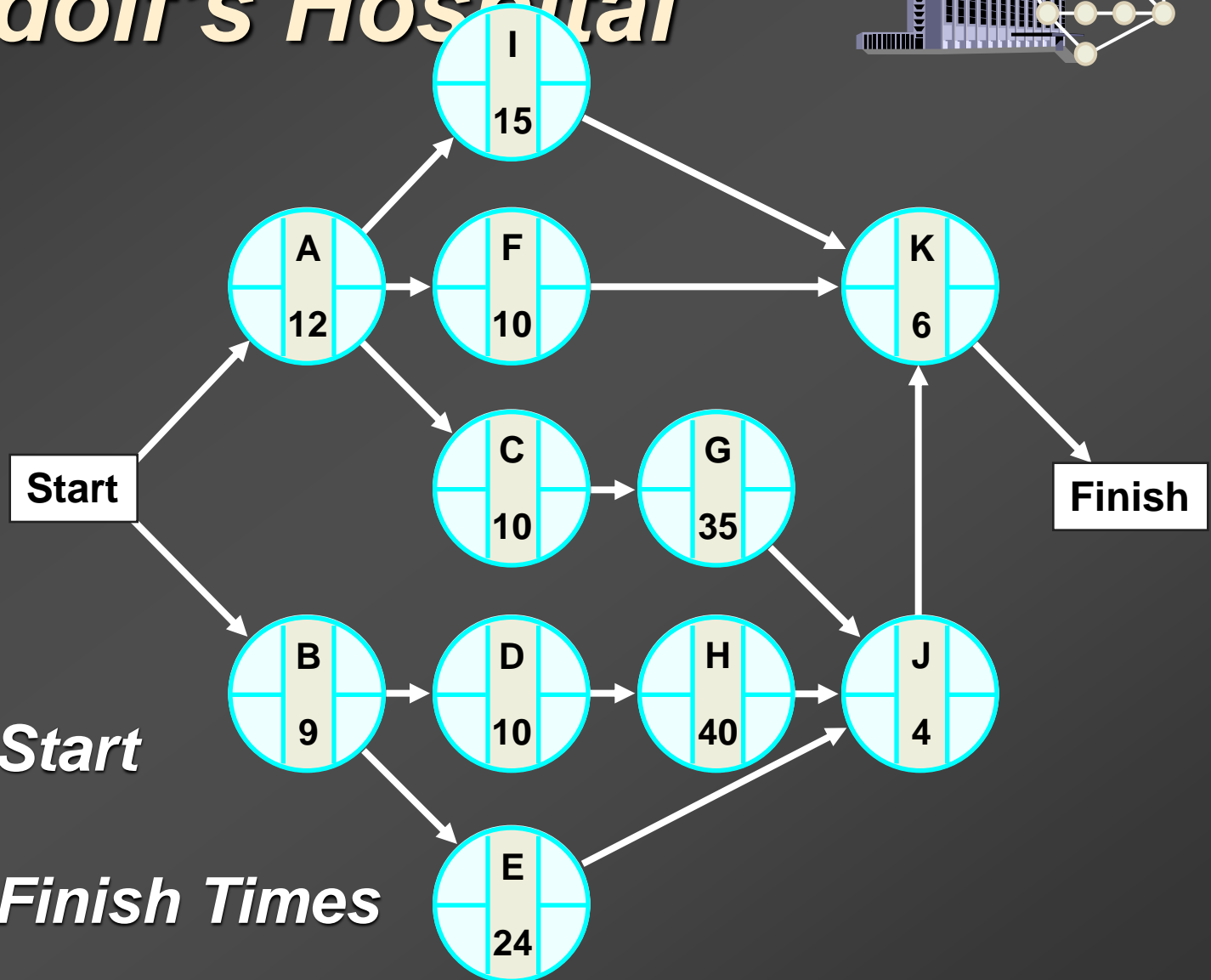
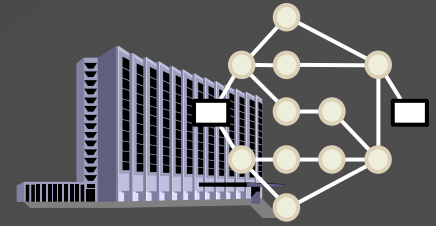

*Earliest Start
and
Earliest Finish Times*

St. Adolf's Hospital

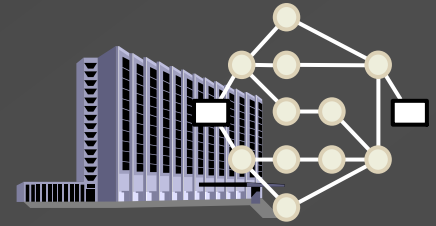

Earliest start time

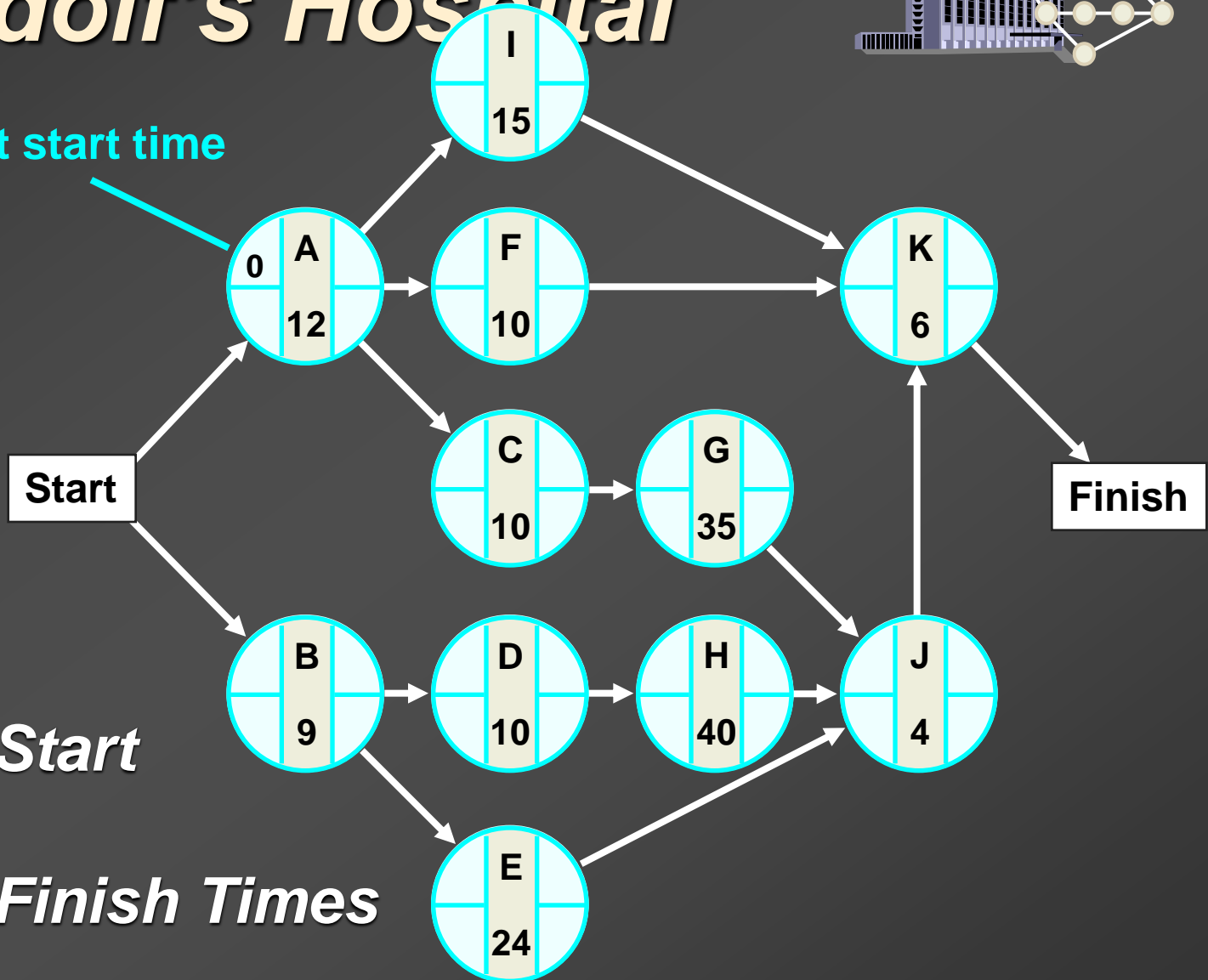

*Earliest Start
and
Earliest Finish Times*

St. Adolf's Hospital

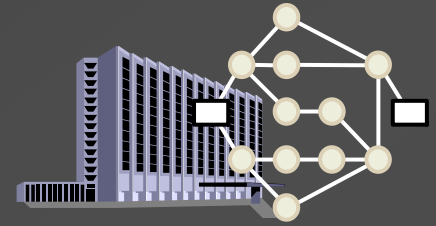

Earliest start time

Earliest finish time

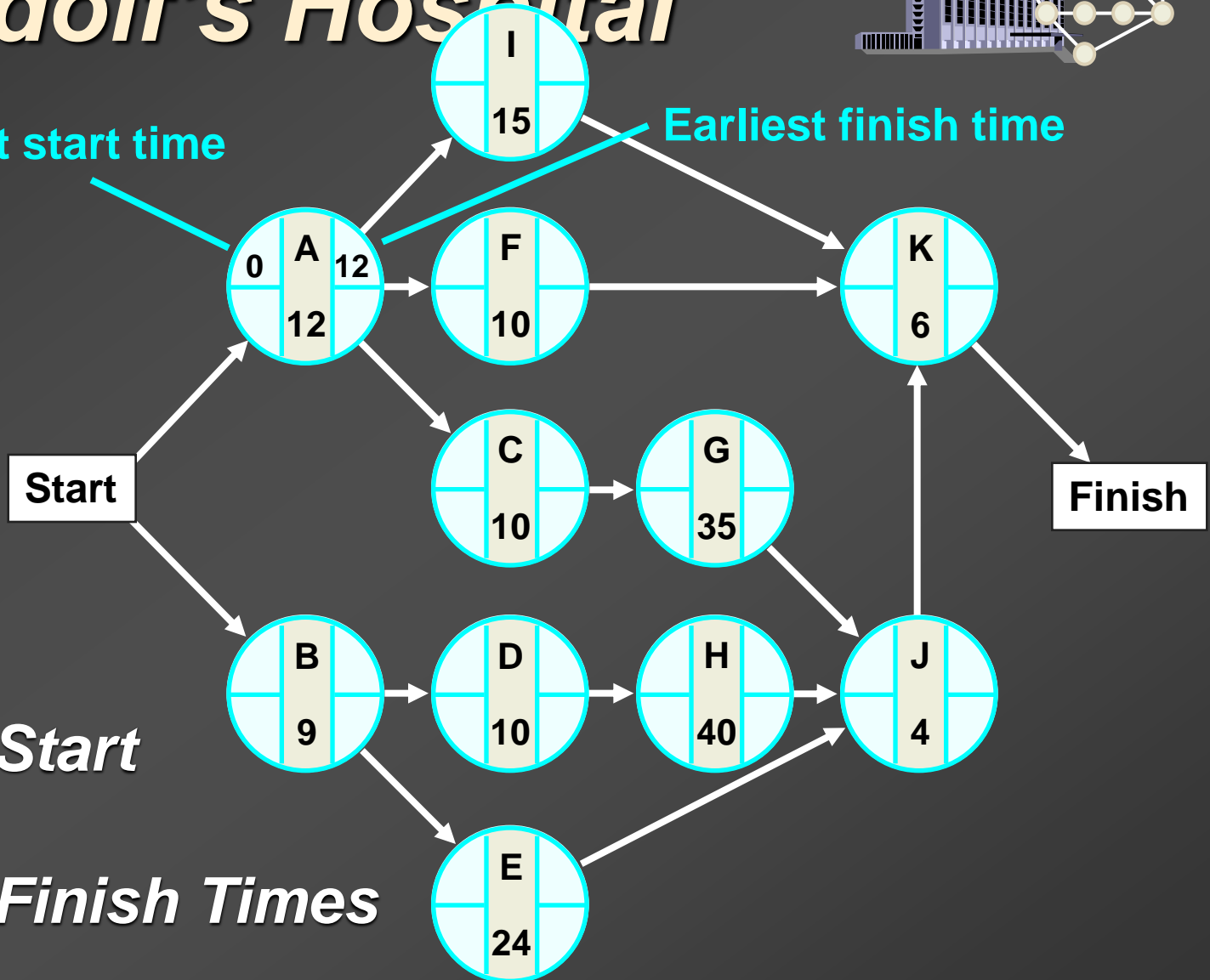

*Earliest Start
and
Earliest Finish Times*

St. Adolf's Hospital

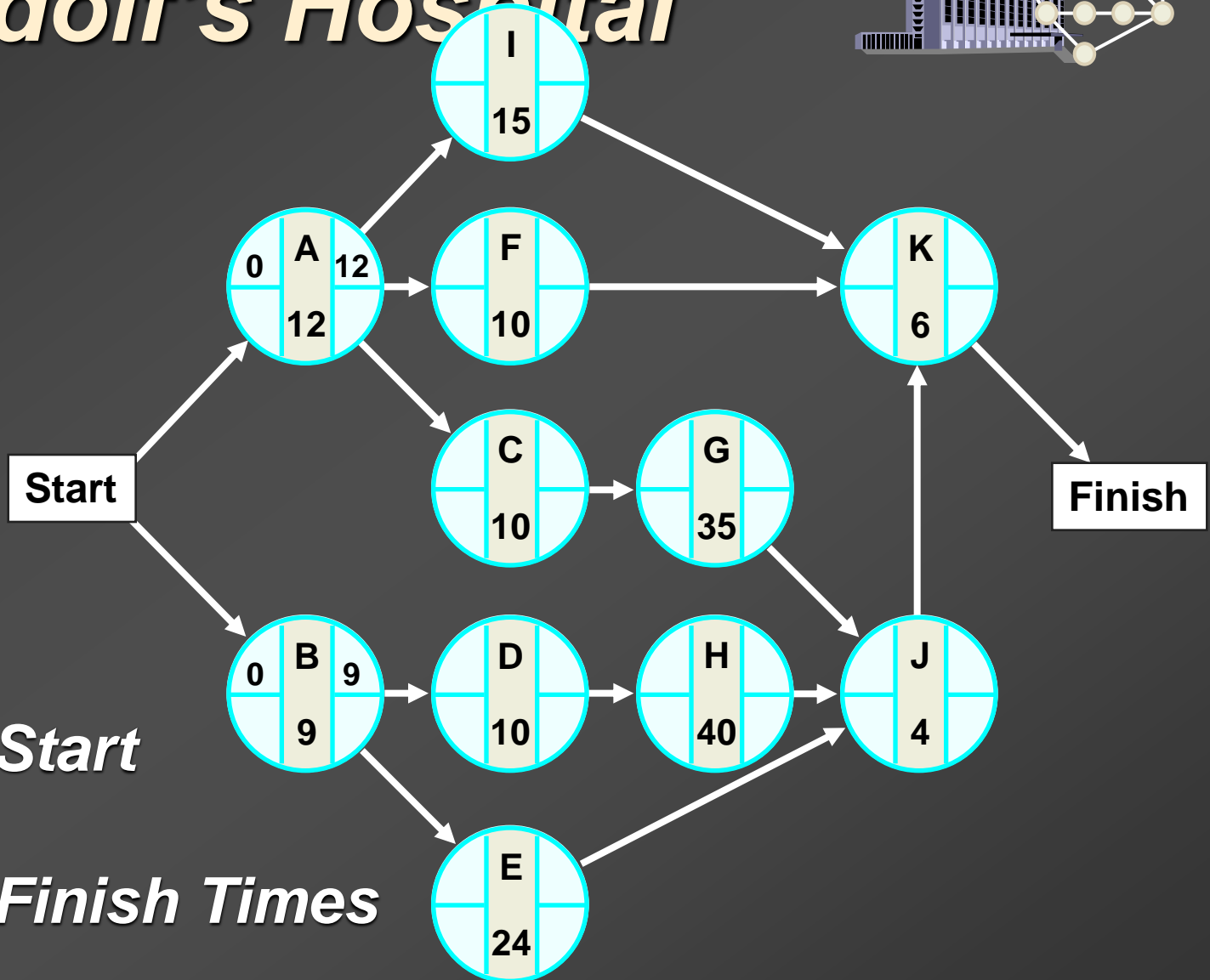
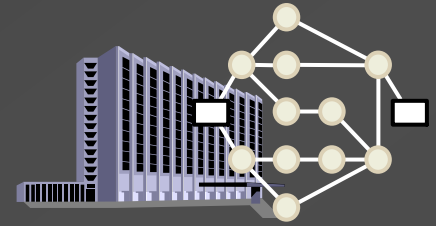

St. Adolf's Hospital

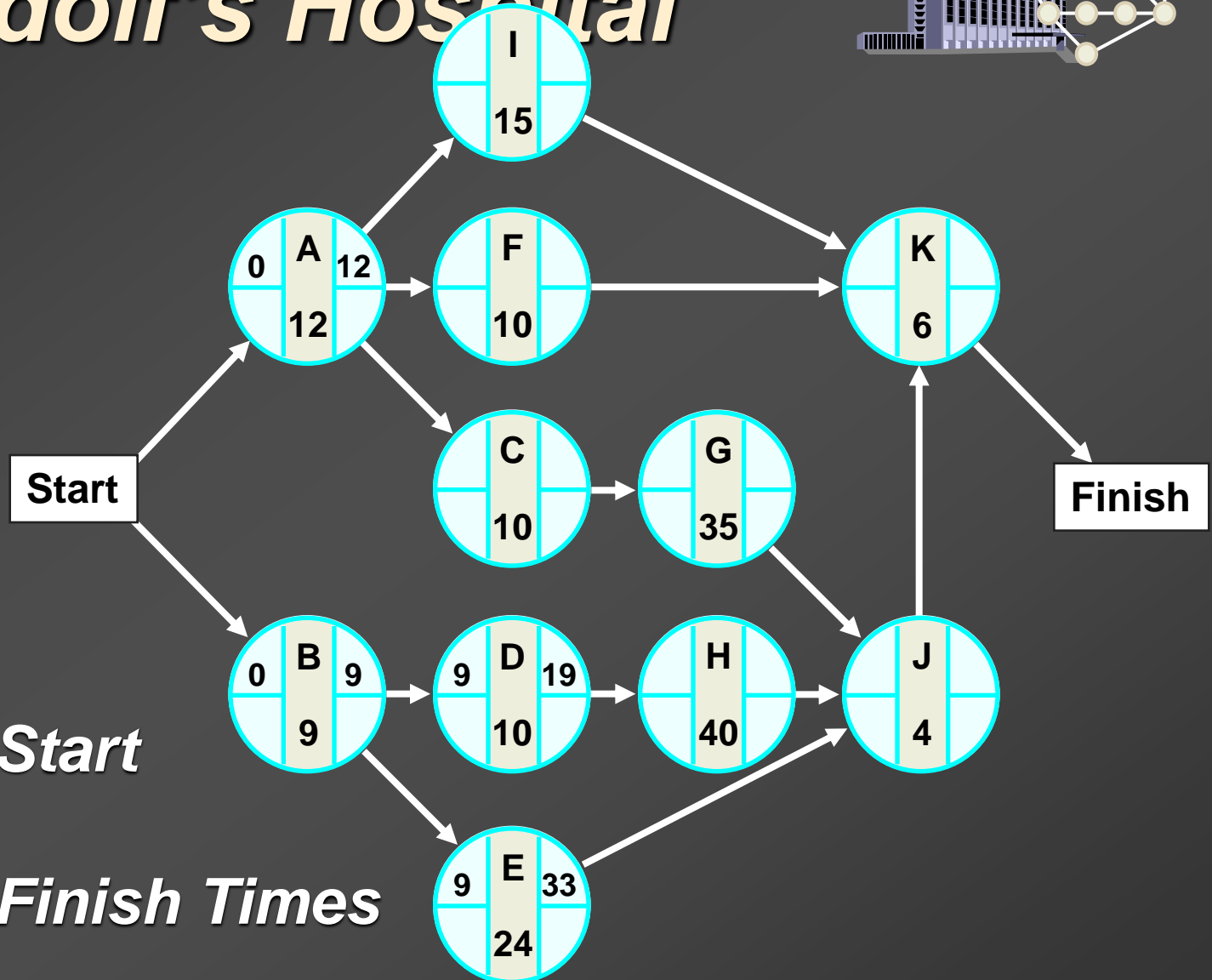
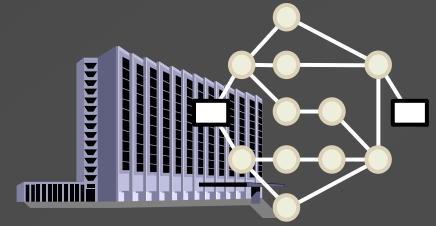

*Earliest Start
and
Earliest Finish Times*

St. Adolf's Hospital

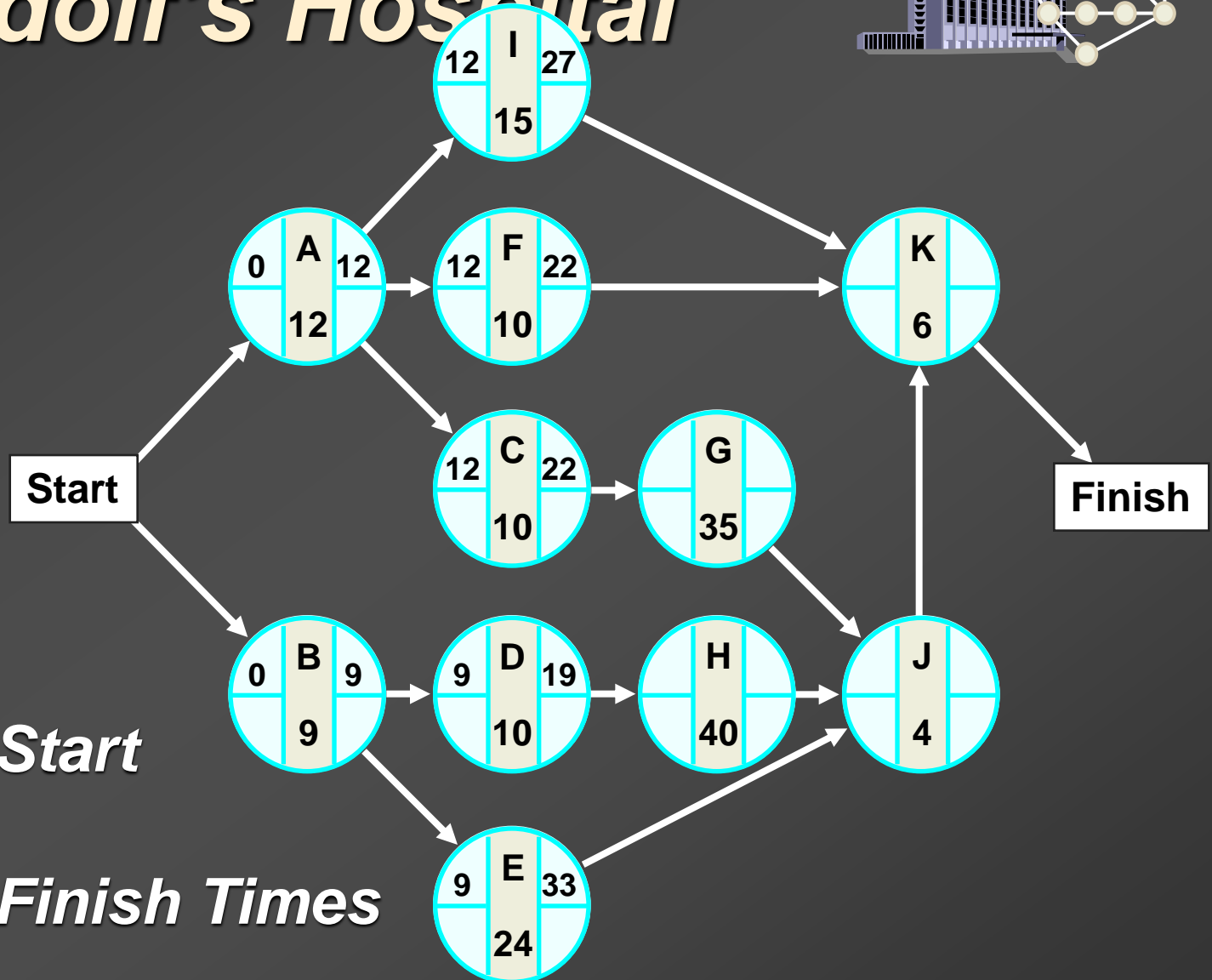
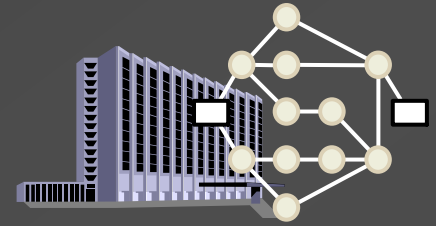

*Earliest Start
and
Earliest Finish Times*

St. Adolf's Hospital

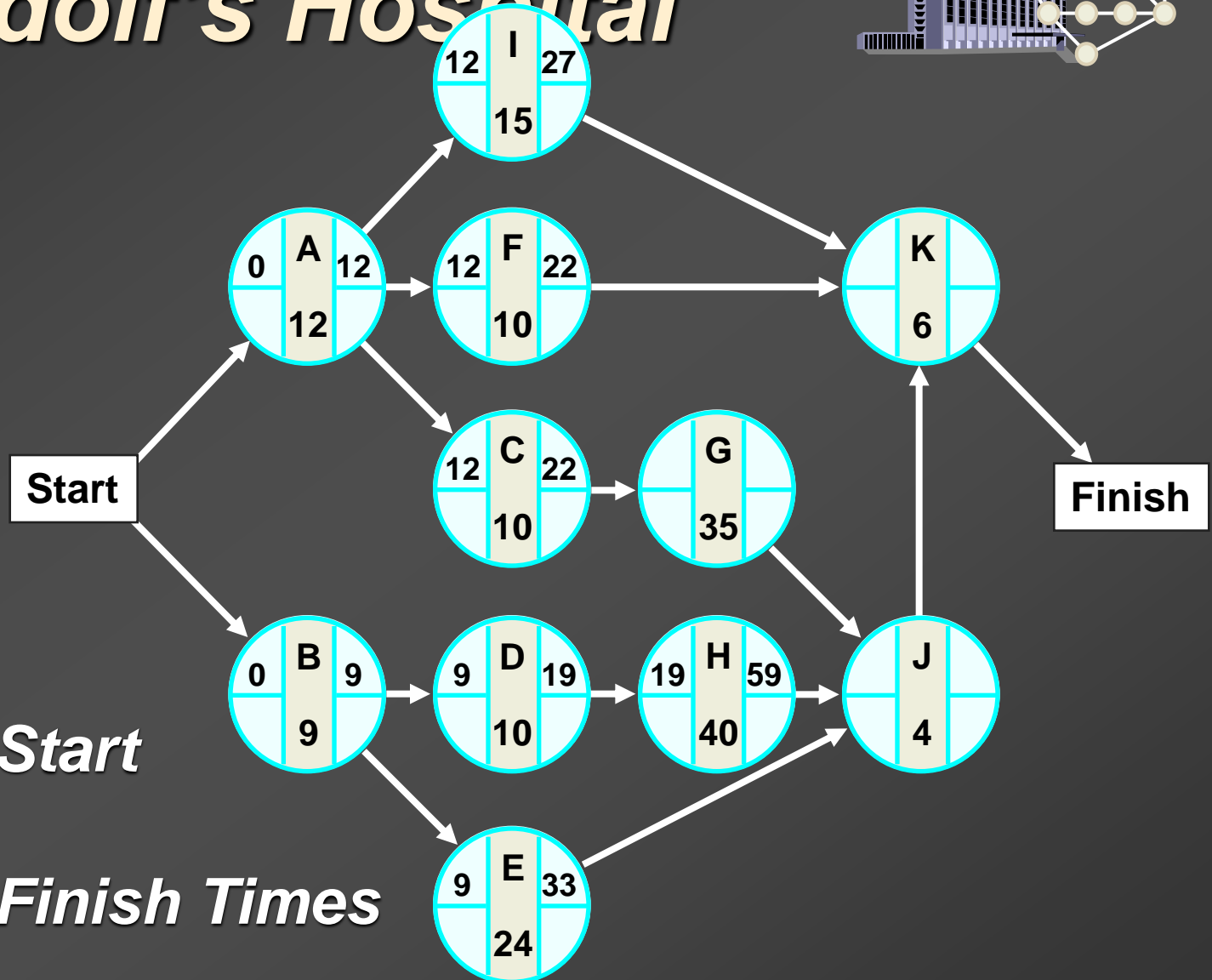
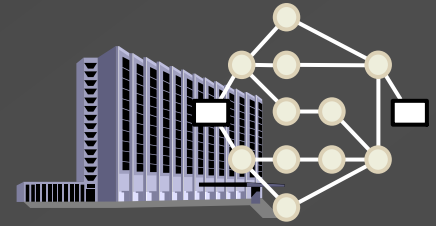

*Earliest Start
and
Earliest Finish Times*

St. Adolf's Hospital

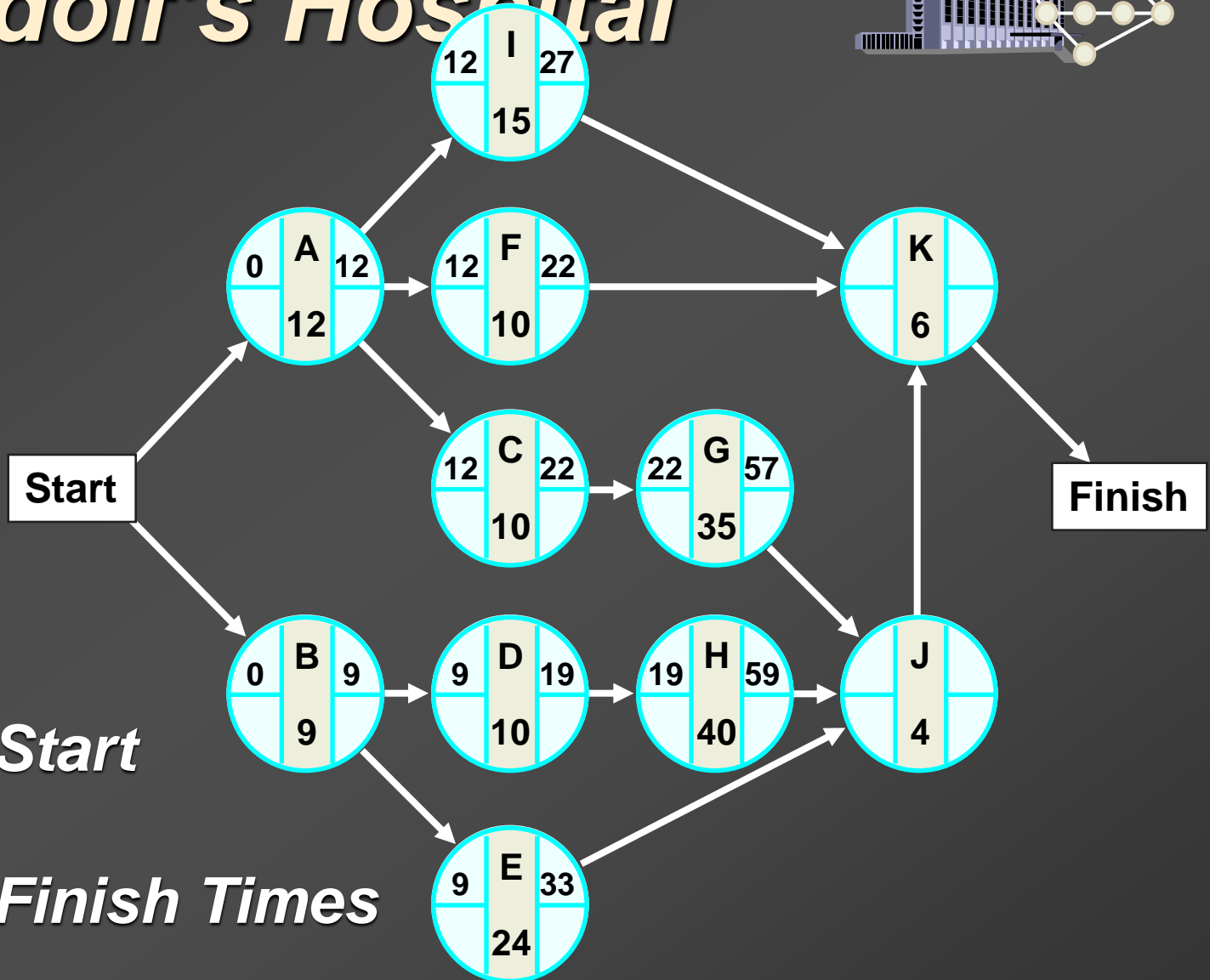
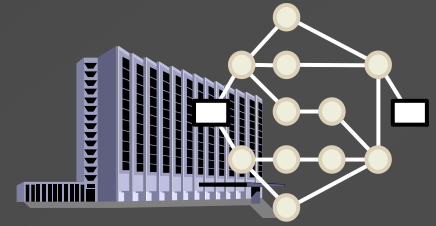

*Earliest Start
and
Earliest Finish Times*

St. Adolf's Hospital

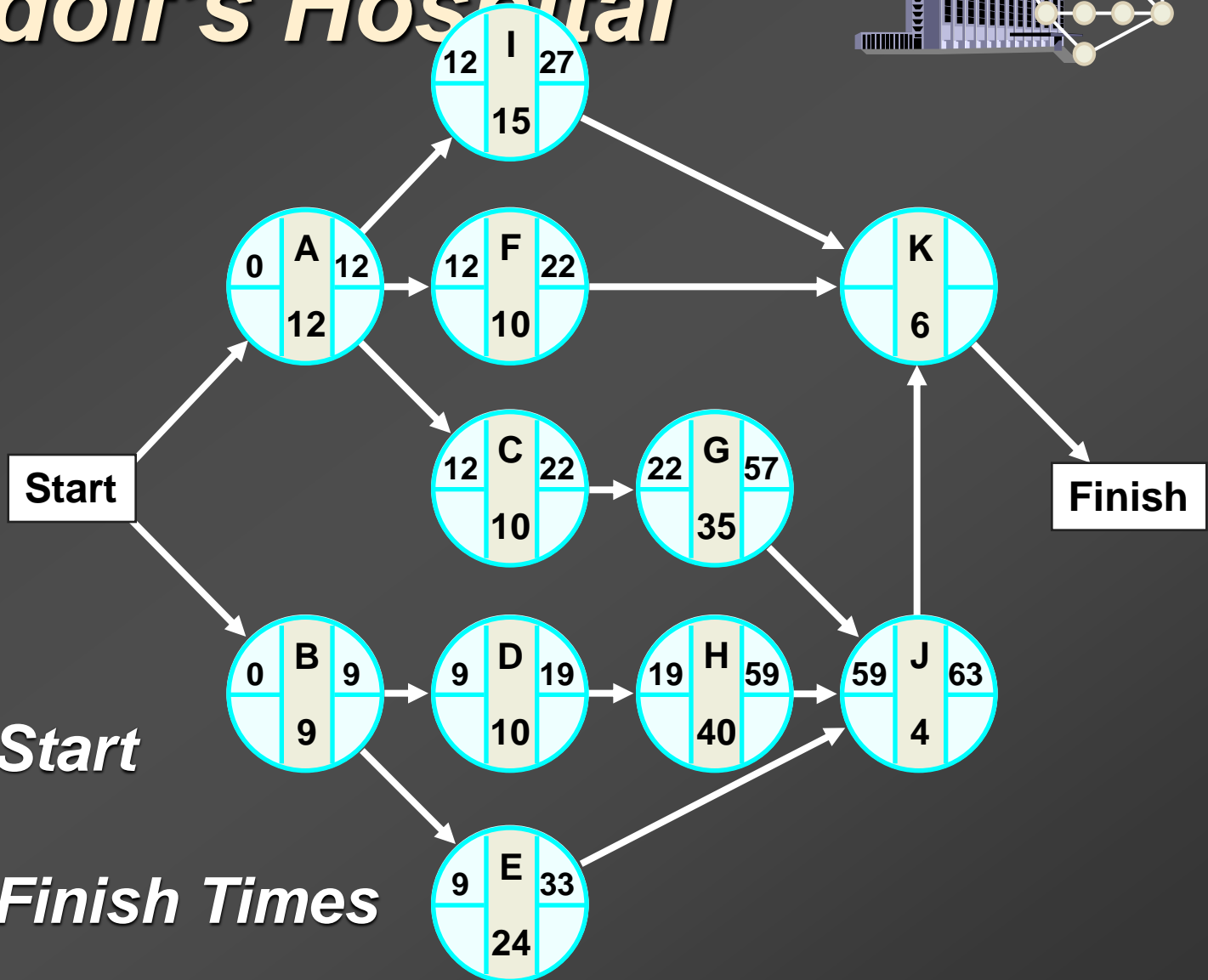
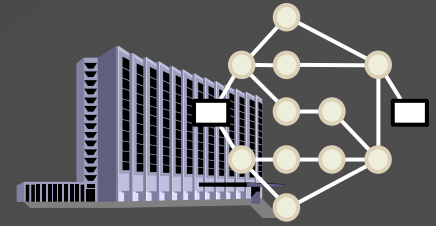

*Earliest Start
and
Earliest Finish Times*

St. Adolf's Hospital

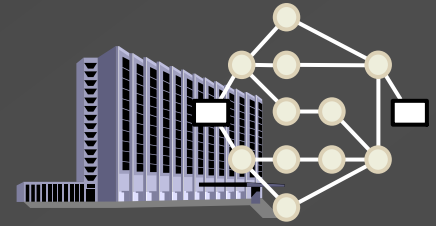

Earliest start time Earliest finish time

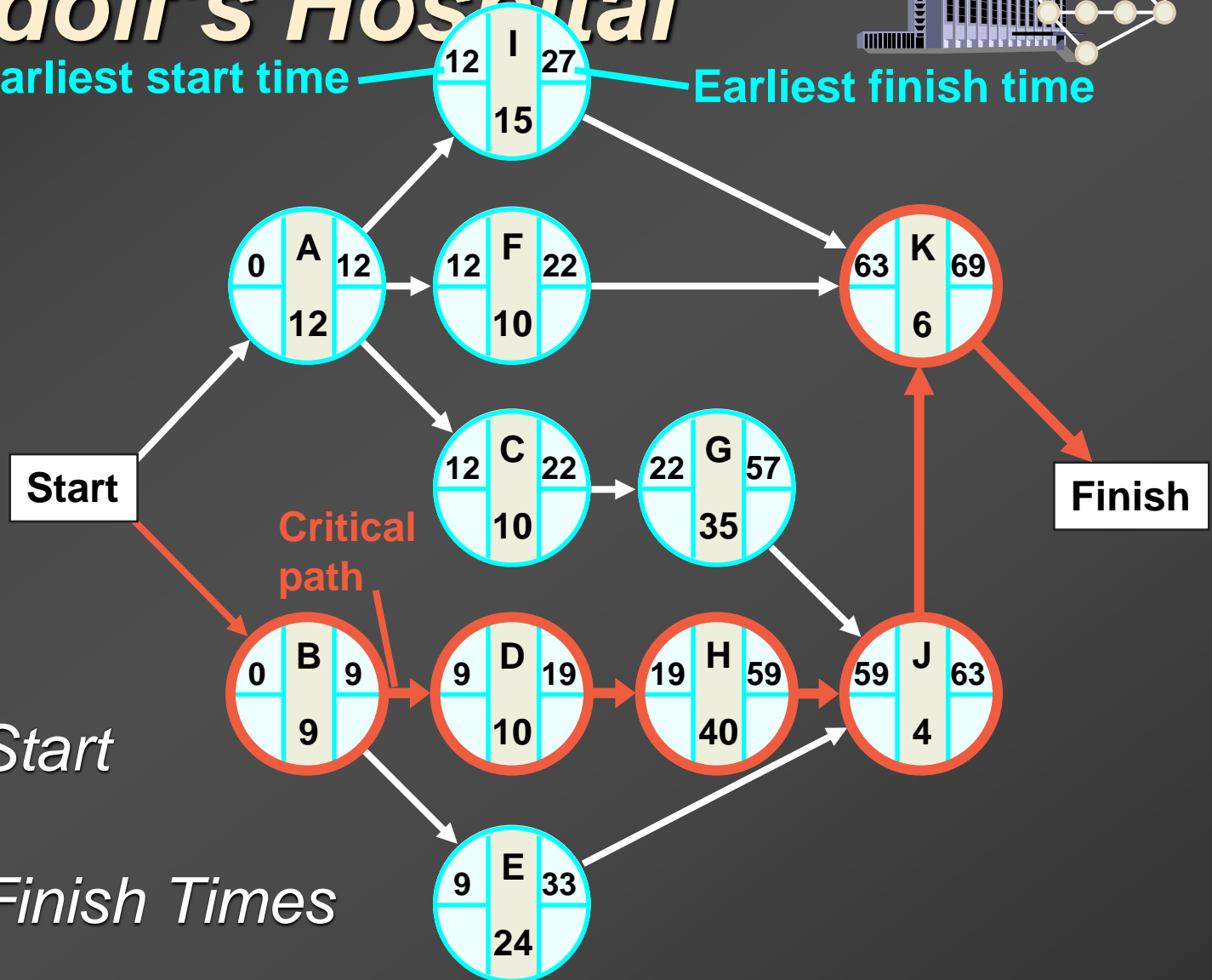

*Earliest Start
and
Earliest Finish Times
first*

St. Adolf's Hospital

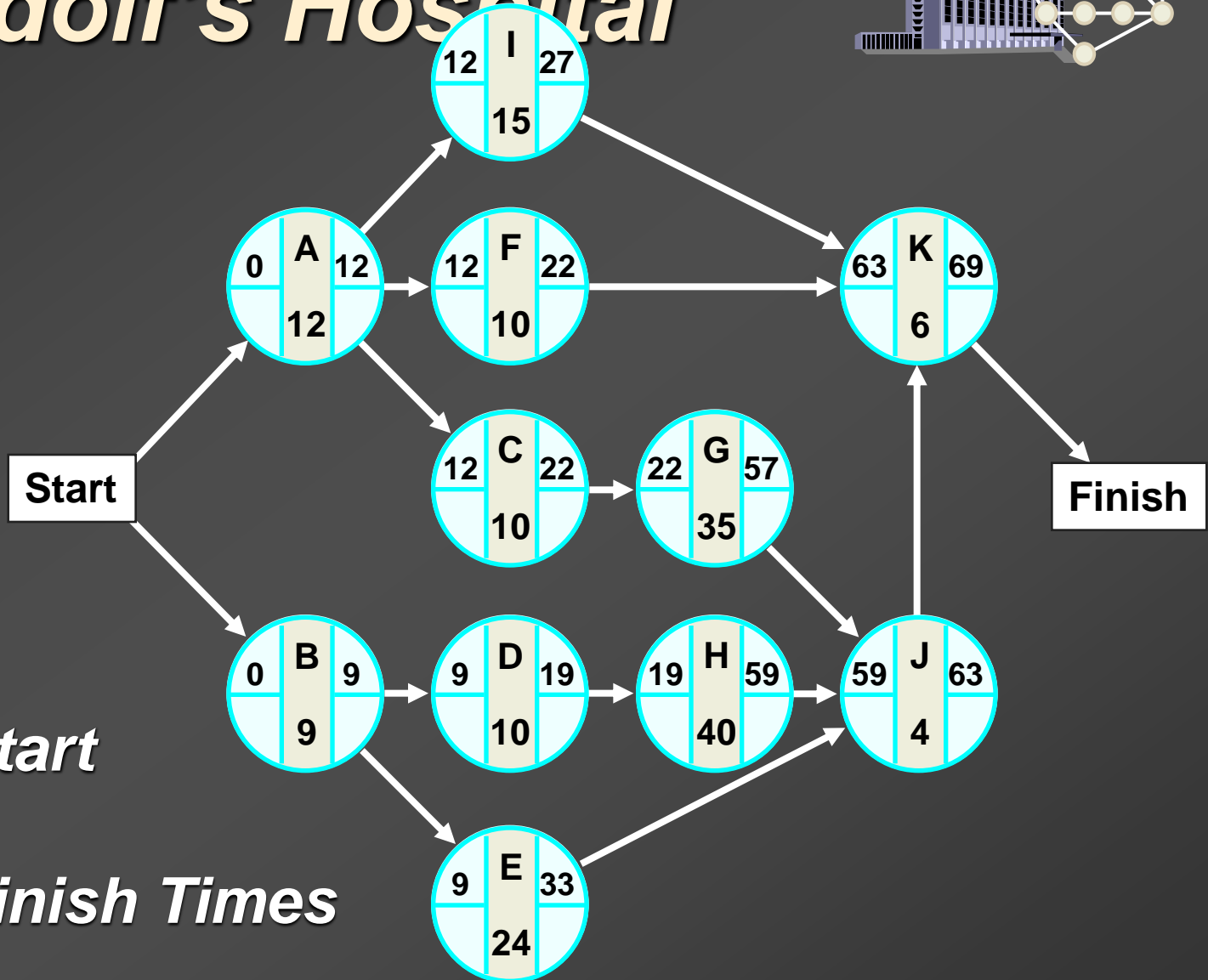
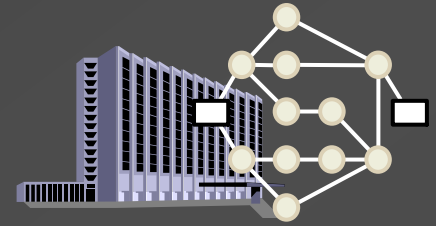

*Latest Start
and
Latest Finish Times*

St. Adolf's Hospital

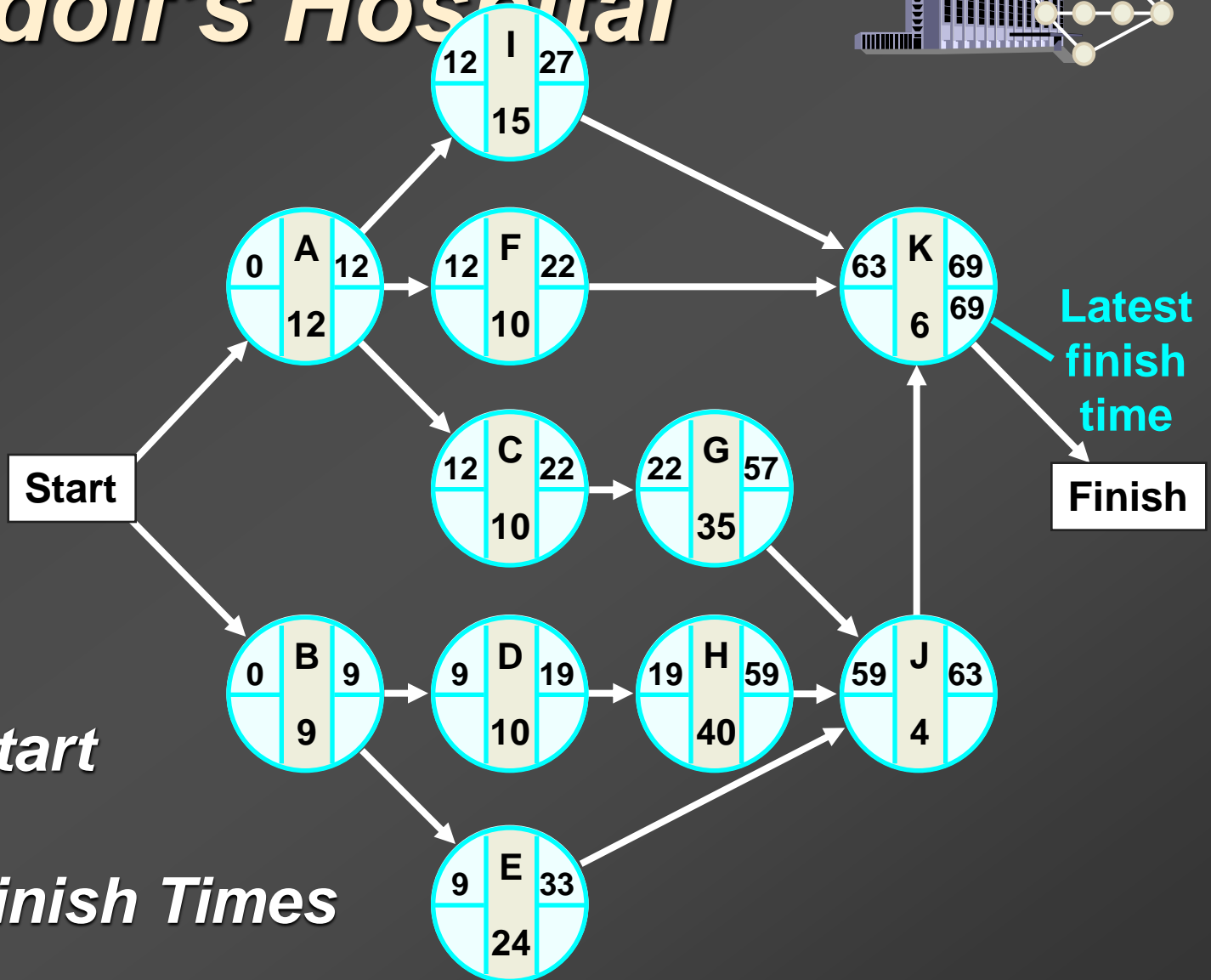
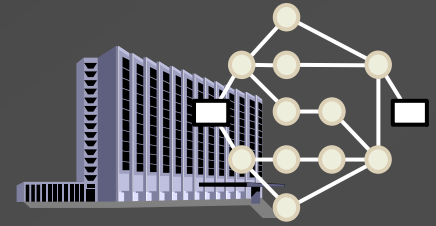

*Latest Start
and
Latest Finish Times*

St. Adolf's Hospital

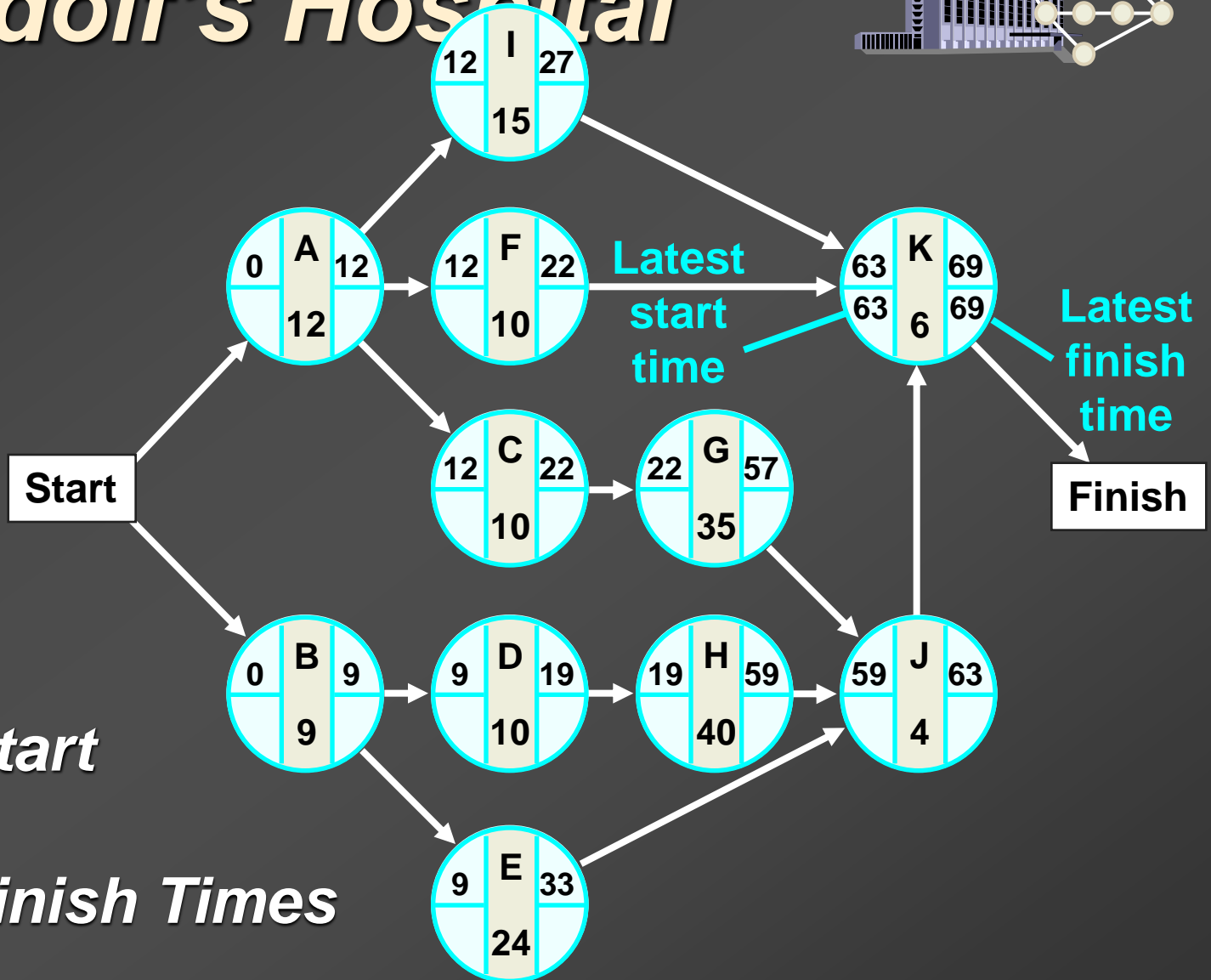
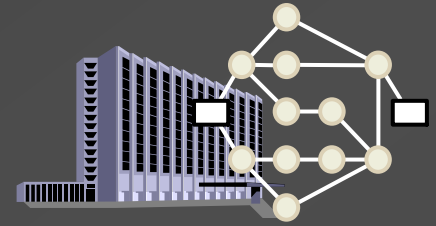

*Latest Start
and
Latest Finish Times*

St. Adolf's Hospital

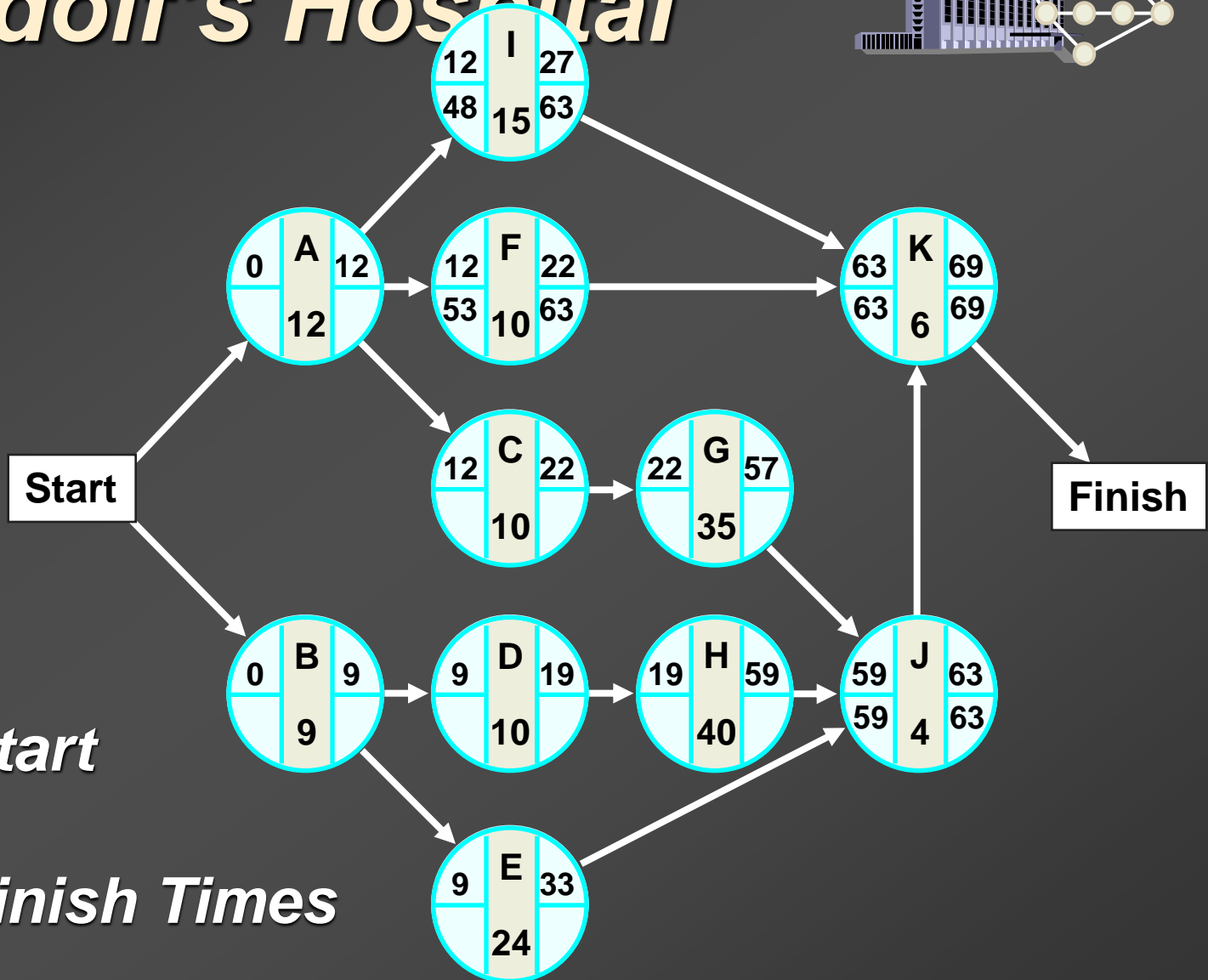
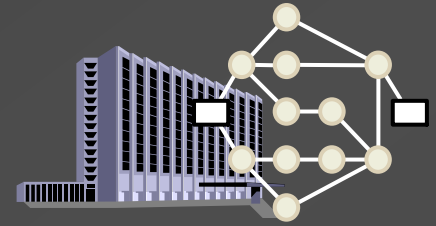

*Latest Start
and
Latest Finish Times*

St. Adolf's Hospital

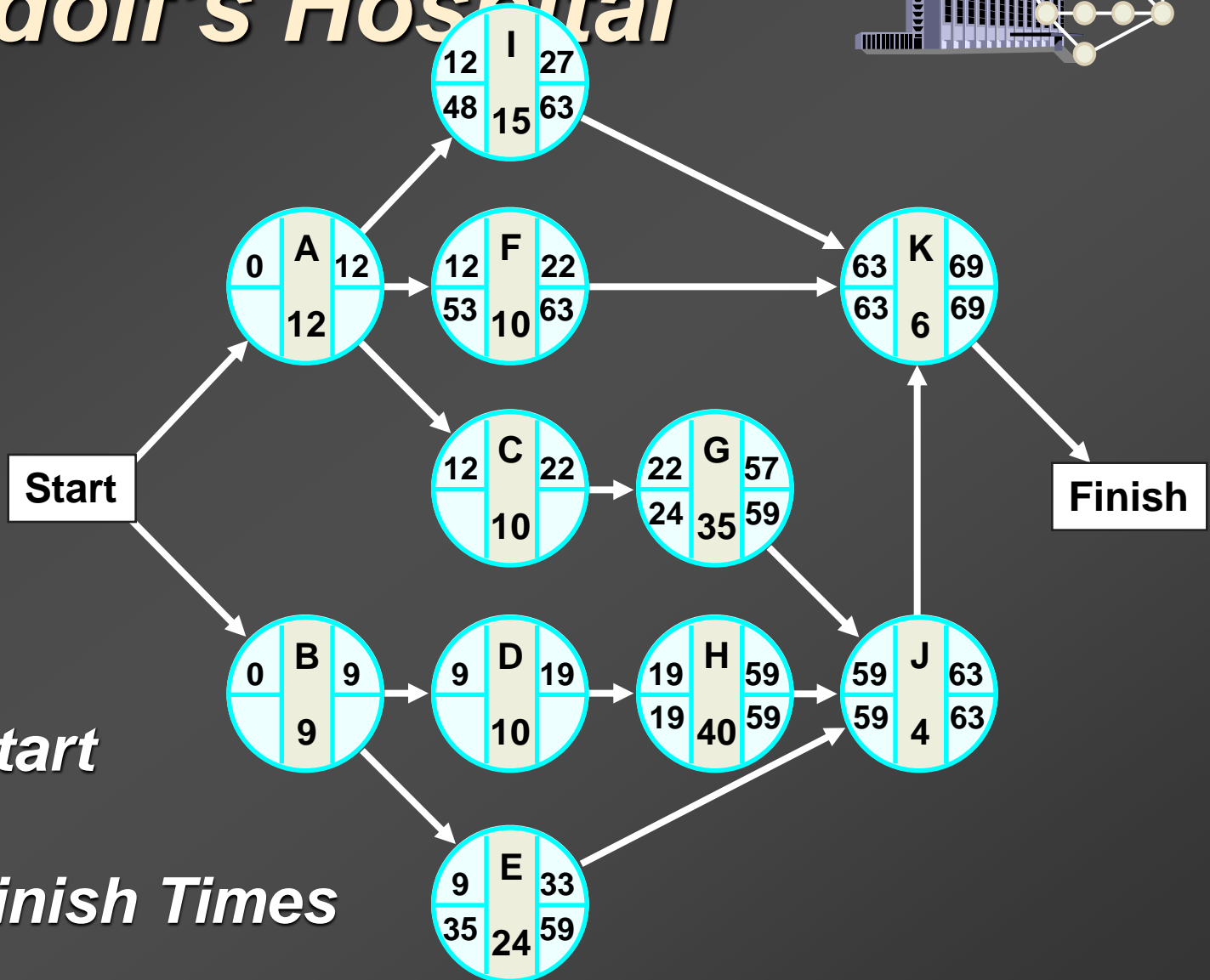
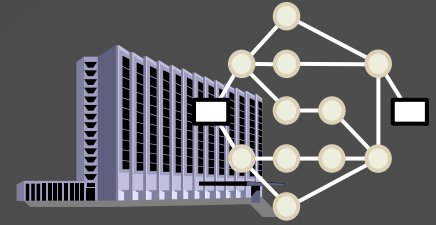

*Latest Start
and
Latest Finish Times*

St. Adolf's Hospital

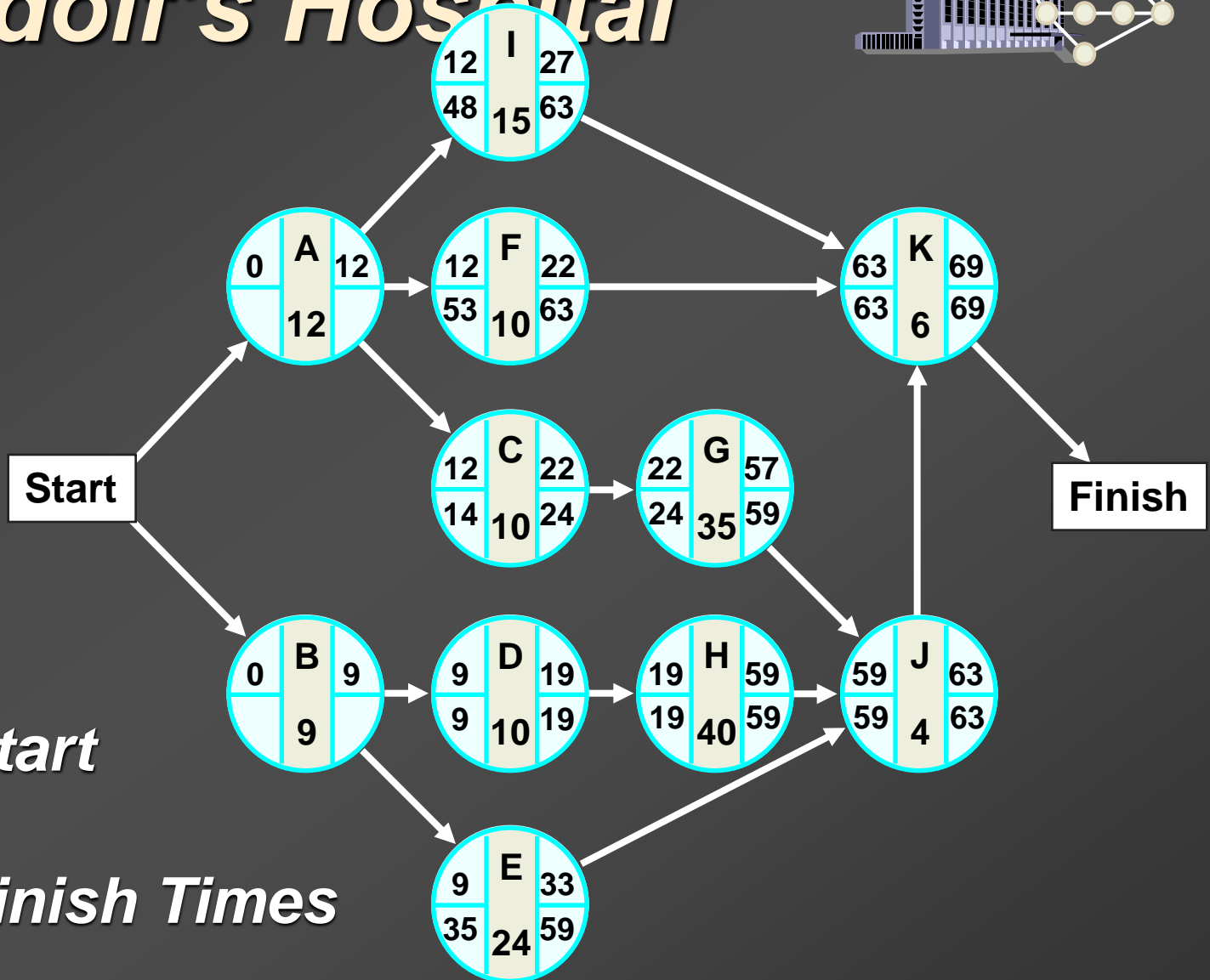
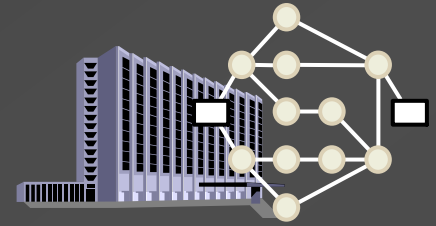

*Latest Start
and
Latest Finish Times*

St. Adolf's Hospital

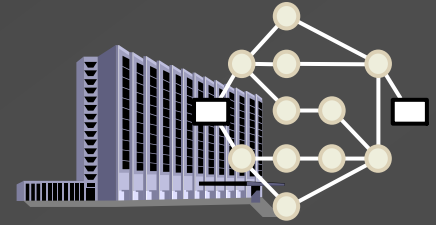

Earliest start time Earliest finish time
 Latest start time Latest finish time

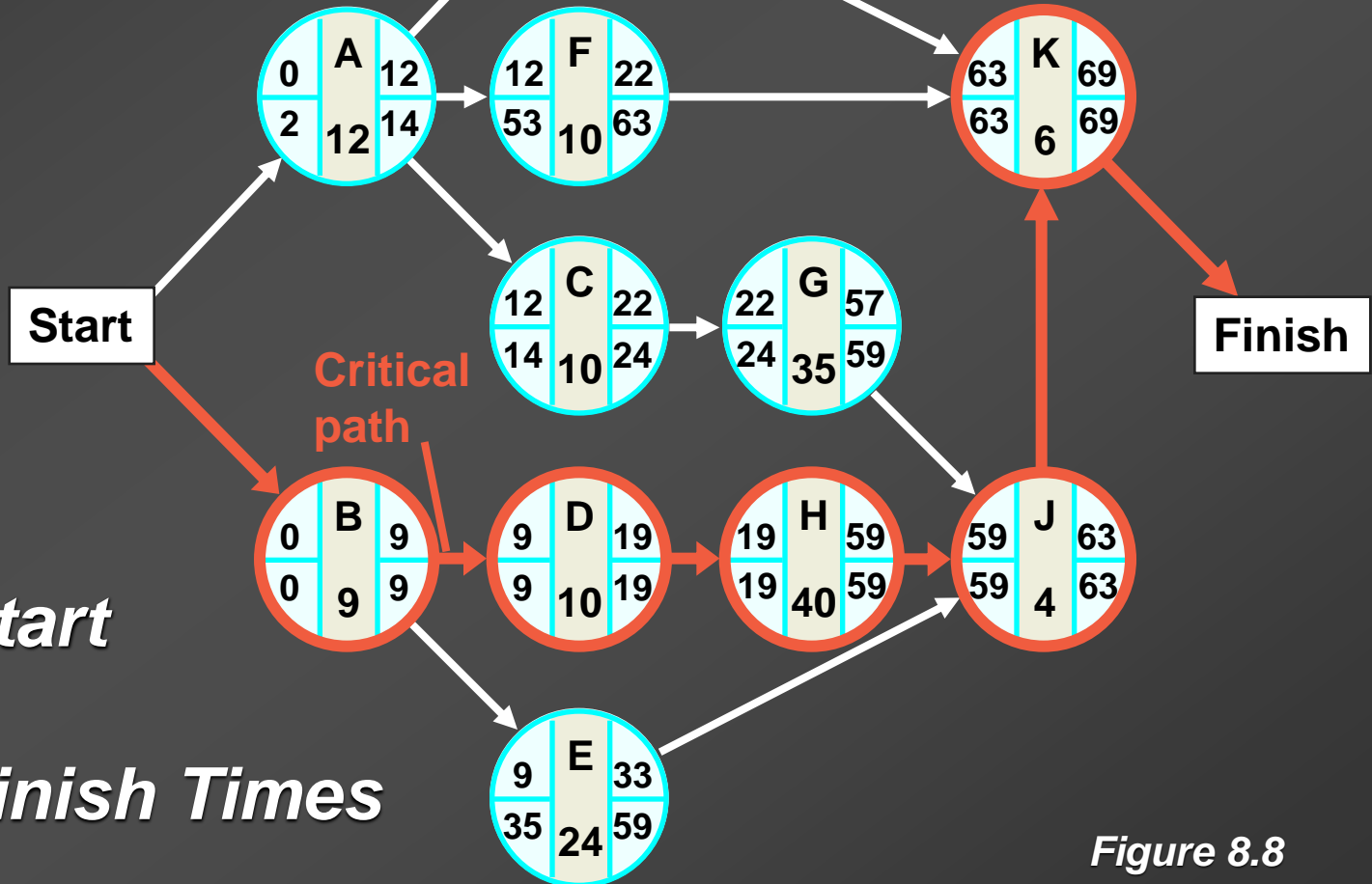

Latest Start
 and
 Latest Finish Times

Figure 8.8

St. Adolf's Hospital

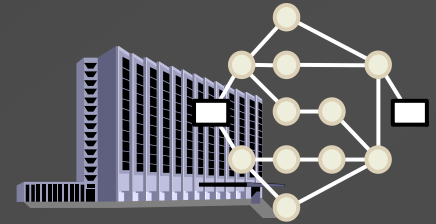

Gantt Charts

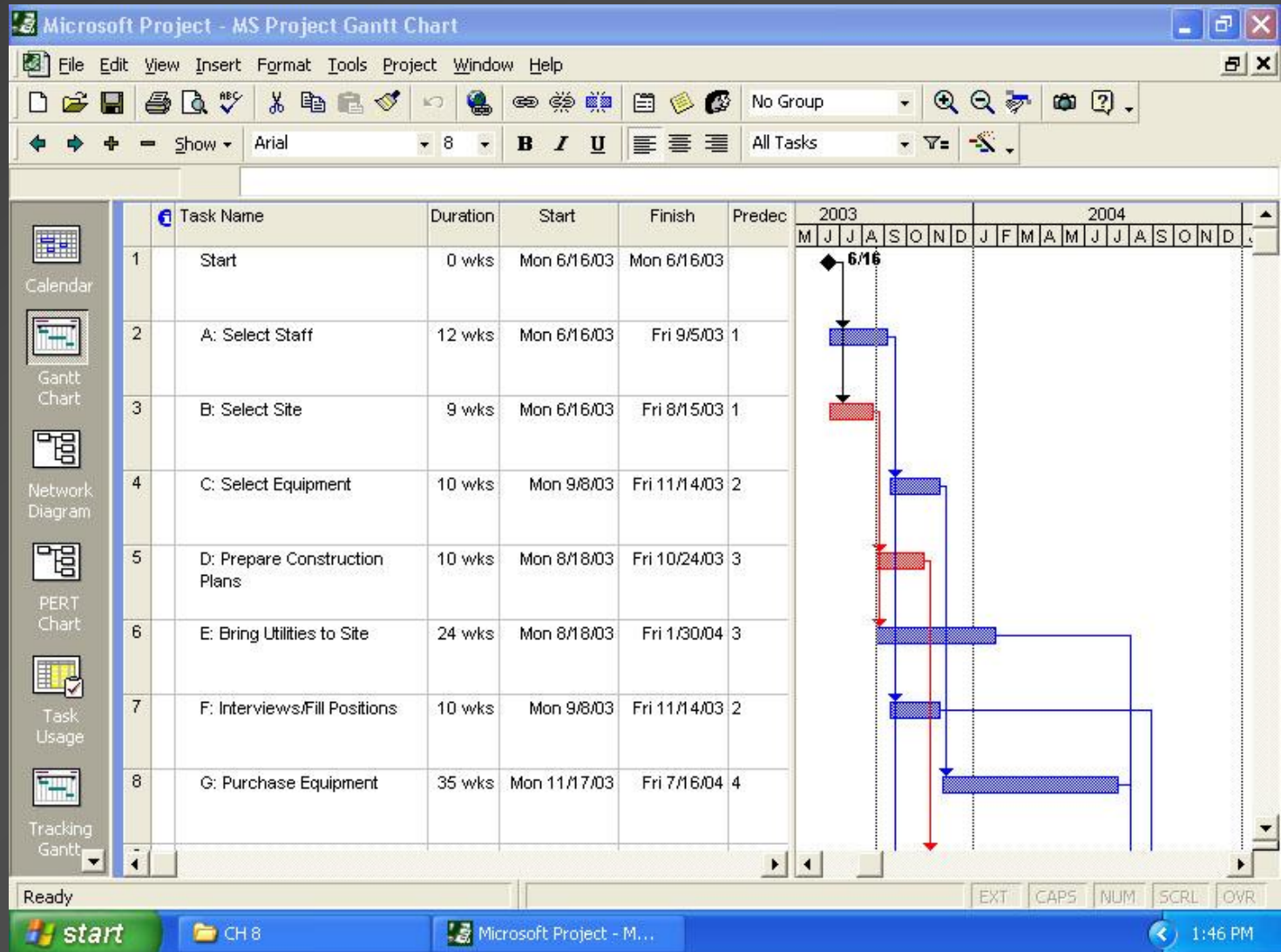

St. Adolf's Hospital

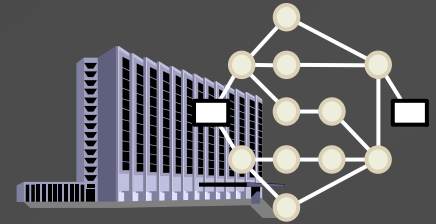

Activity Slack

Microsoft Project - MS Project Schedule Table

File Edit View Insert Format Tools Project Window Help

No Group All Tasks

Task Name	Start	Finish	Late Start	Late Finish	Free Slack	Total Slack
1 Start	Mon 6/16/03	Mon 6/16/03	Mon 6/16/03	Mon 6/16/03	0 wks	0 wks
2 A: Select Staff	Mon 6/16/03	Fri 9/5/03	Mon 6/30/03	Fri 9/19/03	0 wks	2 wks
3 B: Select Site	Mon 6/16/03	Fri 8/15/03	Mon 6/16/03	Fri 8/15/03	0 wks	0 wks
4 C: Select Equipment	Mon 9/8/03	Fri 11/14/03	Mon 9/22/03	Fri 11/28/03	0 wks	2 wks
5 D: Prepare Construction Plans	Mon 8/18/03	Fri 10/24/03	Mon 8/18/03	Fri 10/24/03	0 wks	0 wks
6 E: Bring Utilities to Site	Mon 8/18/03	Fri 1/30/04	Mon 2/16/04	Fri 7/30/04	26 wks	26 wks
7 F: Interviews/Fill Positions	Mon 9/8/03	Fri 11/14/03	Mon 6/21/04	Fri 8/27/04	41 wks	41 wks
8 G: Purchase Equipment	Mon 11/17/03	Fri 7/16/04	Mon 12/1/03	Fri 7/30/04	2 wks	2 wks
9 H: Construct Hospital	Mon 10/27/03	Fri 7/30/04	Mon 10/27/03	Fri 7/30/04	0 wks	0 wks
10 I: Develop Information System	Mon 9/8/03	Fri 12/19/03	Mon 5/17/04	Fri 8/27/04	36 wks	36 wks
11 J: Install Equipment	Mon 8/2/04	Fri 8/27/04	Mon 8/2/04	Fri 8/27/04	0 wks	0 wks
12 K: Train Staff	Mon 8/30/04	Fri 10/8/04	Mon 8/30/04	Fri 10/8/04	0 wks	0 wks
13 Finish	Fri 10/8/04	Fri 10/8/04	Fri 10/8/04	Fri 10/8/04	0 wks	0 wks

Ready EXT CAPS NUM SCRL OVR

start CH 8 Microsoft Project - M... 2:11 PM

St. Adolf's Hospital

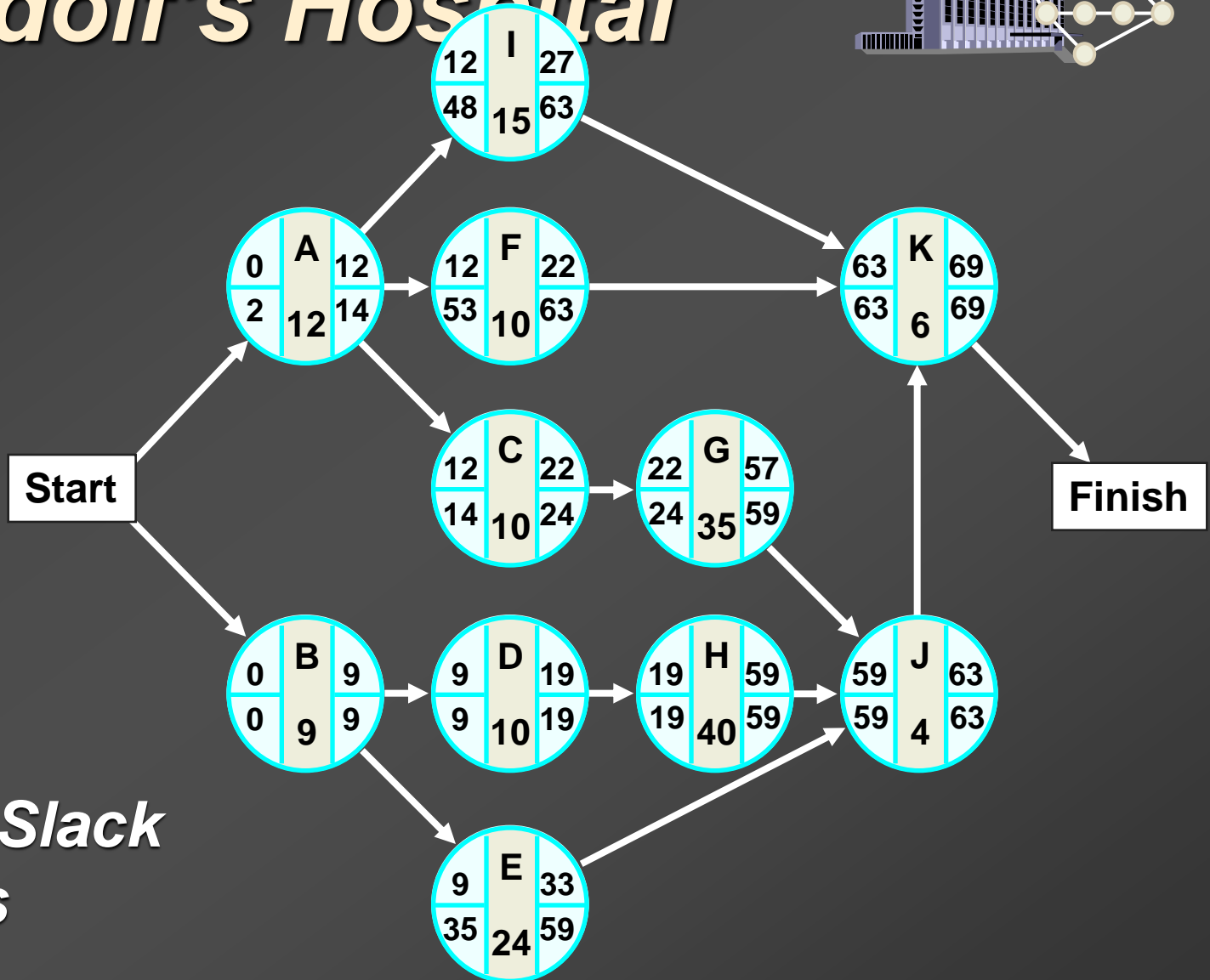
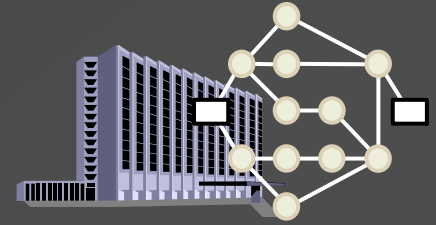

Activity Slack

ospital

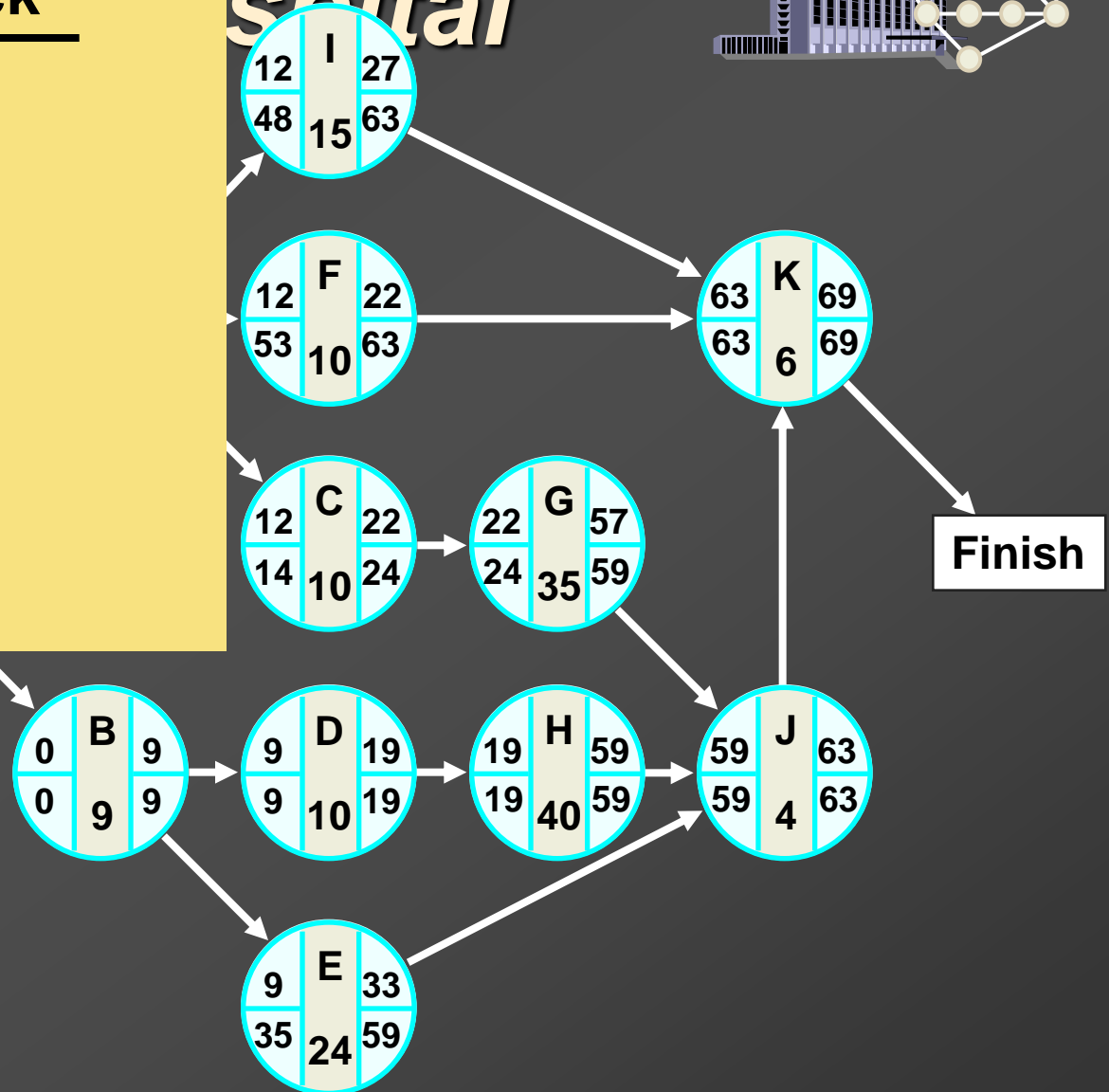
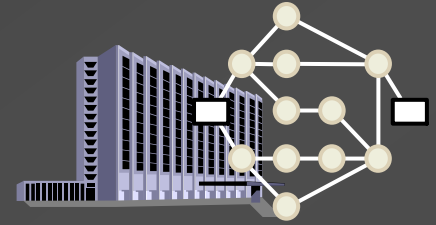

Activity Slack Analysis

Activity Slack

$$\text{Slack} = LS - ES$$

or

$$\text{Slack} = LF - EF$$

ospital

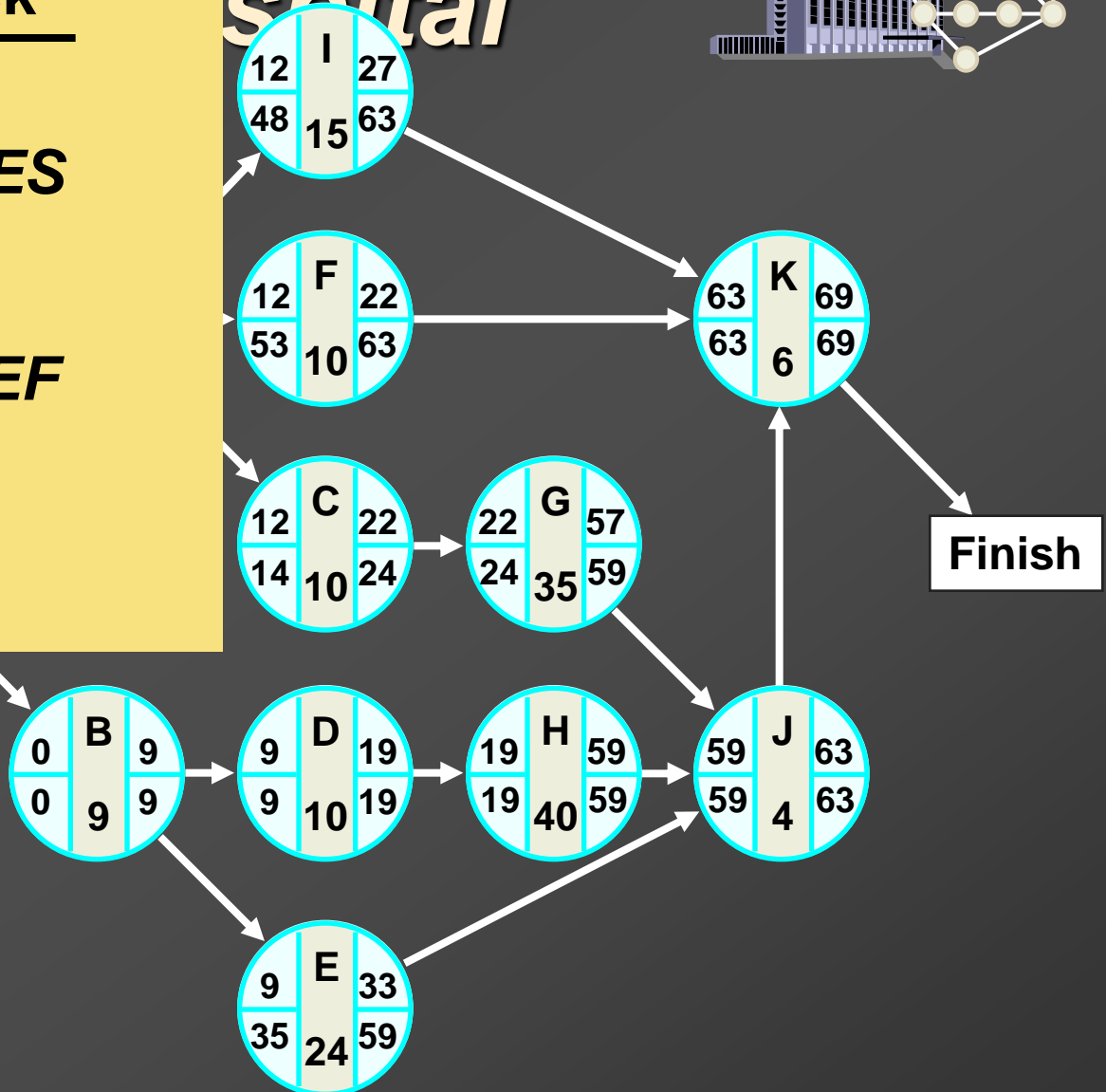
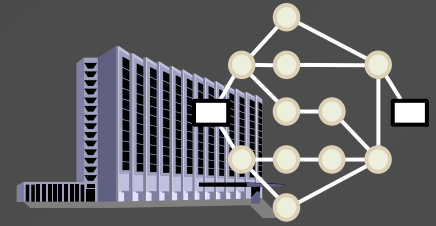

Activity Slack Analysis

Activity Slack

$$\text{Slack}_K = 63 - 63$$

or

$$\text{Slack}_K = 69 - 69$$

ospital

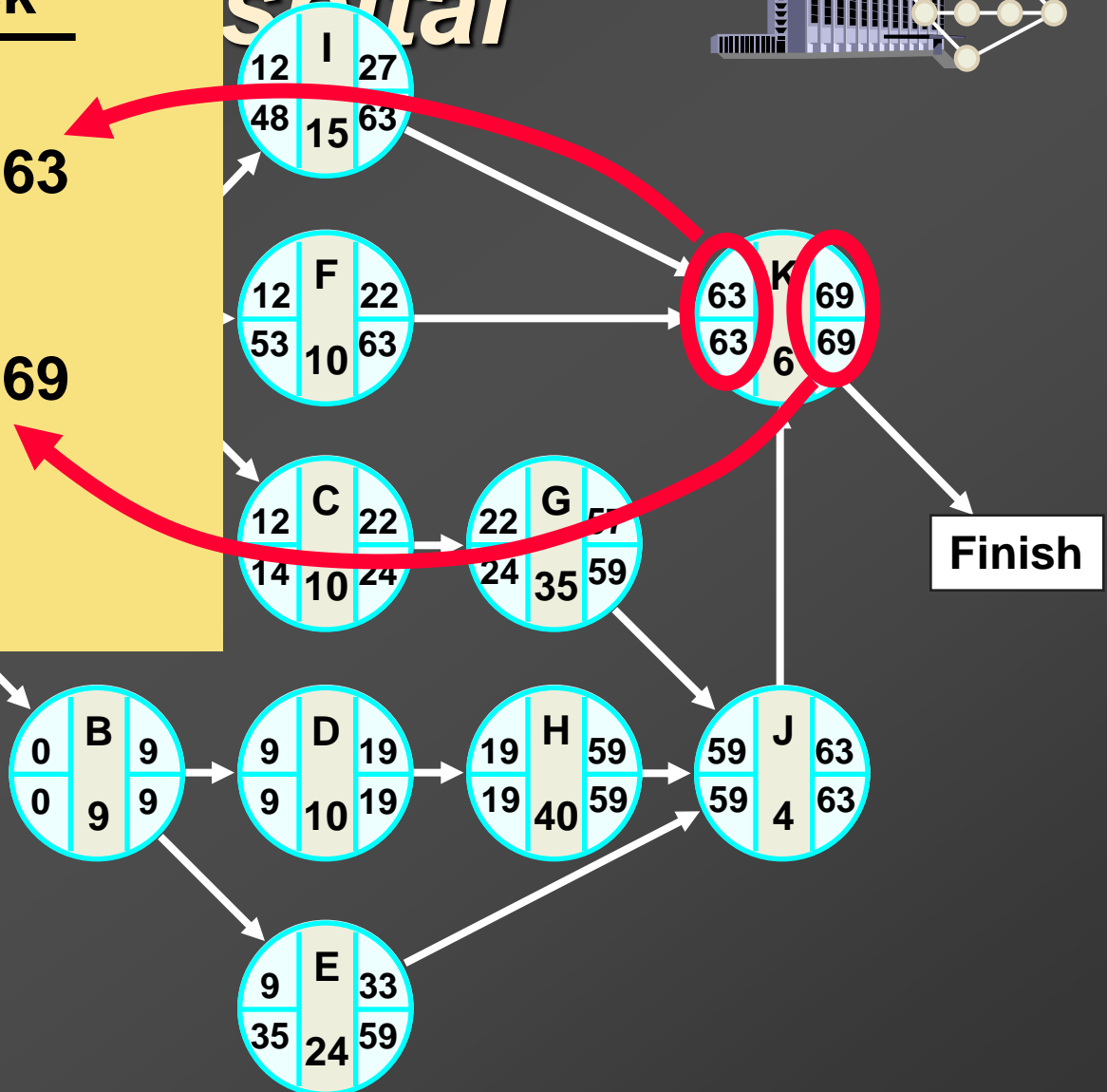
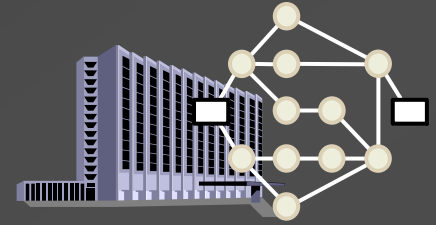

Activity Slack Analysis

Activity Slack

$$\text{Slack}_K = 0$$

or

$$\text{Slack}_K = 0$$

ospital

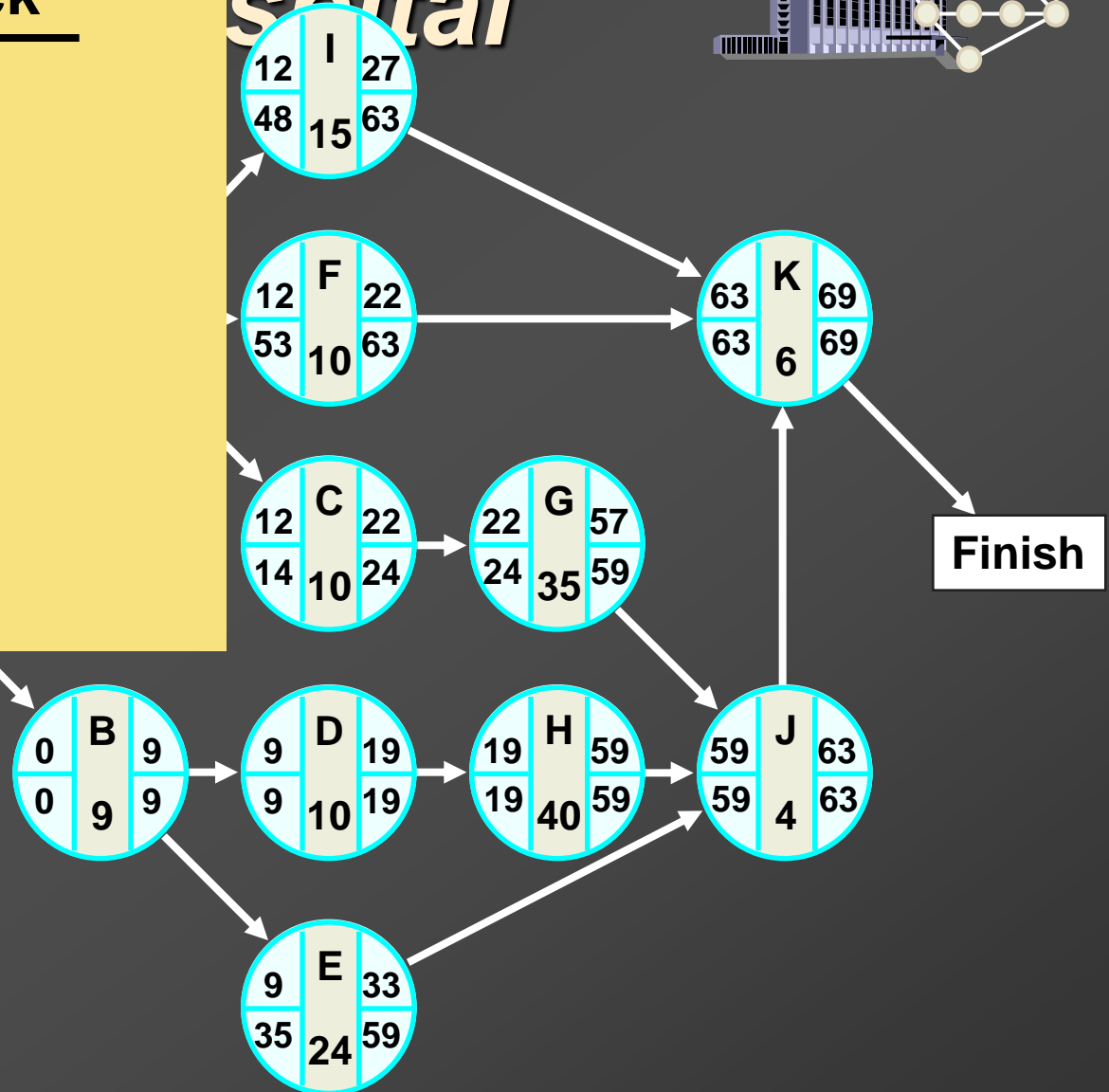
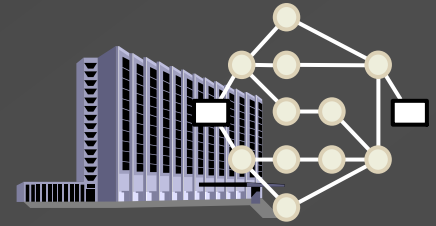

Activity Slack Analysis

ospital

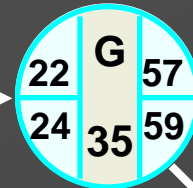
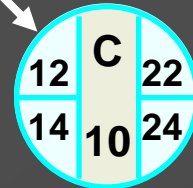
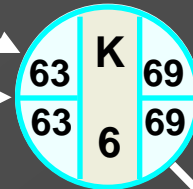
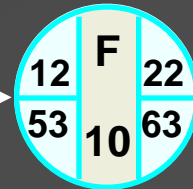
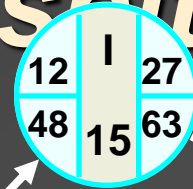
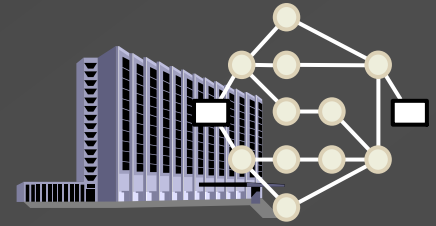

Finish

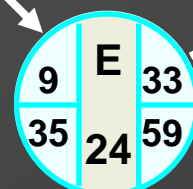
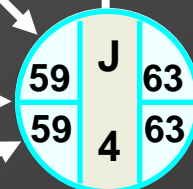
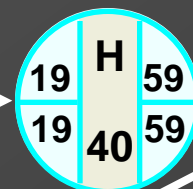
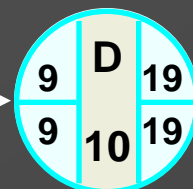
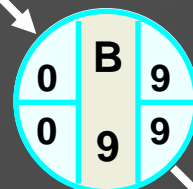

Activity Slack Analysis

Node Duration ES LS Slack

ospital

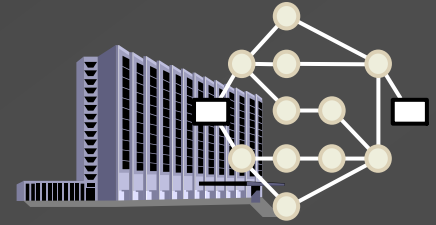

Activity Slack Analysis

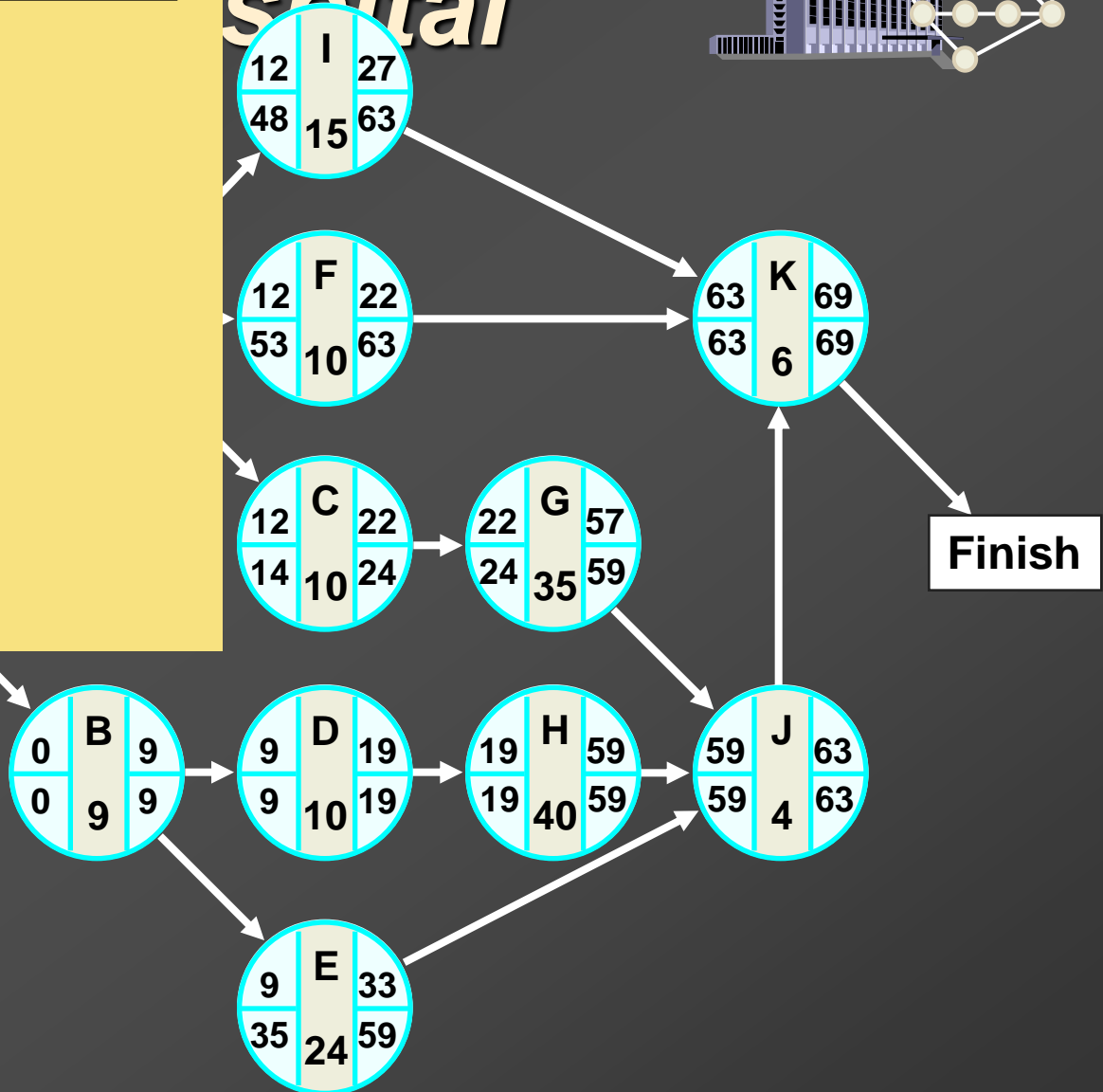

Node Duration ES LS Slack

Node	Duration	ES	LS	Slack
A	12	0	2	2
B	9	0	0	0
C	10	12	14	2
D	10	9	9	0
E	24	9	35	26
F	10	12	53	41
G	35	22	24	2
H	40	19	19	0
I	15	12	48	36
J	4	59	59	0
K	6	63	63	0

ospital

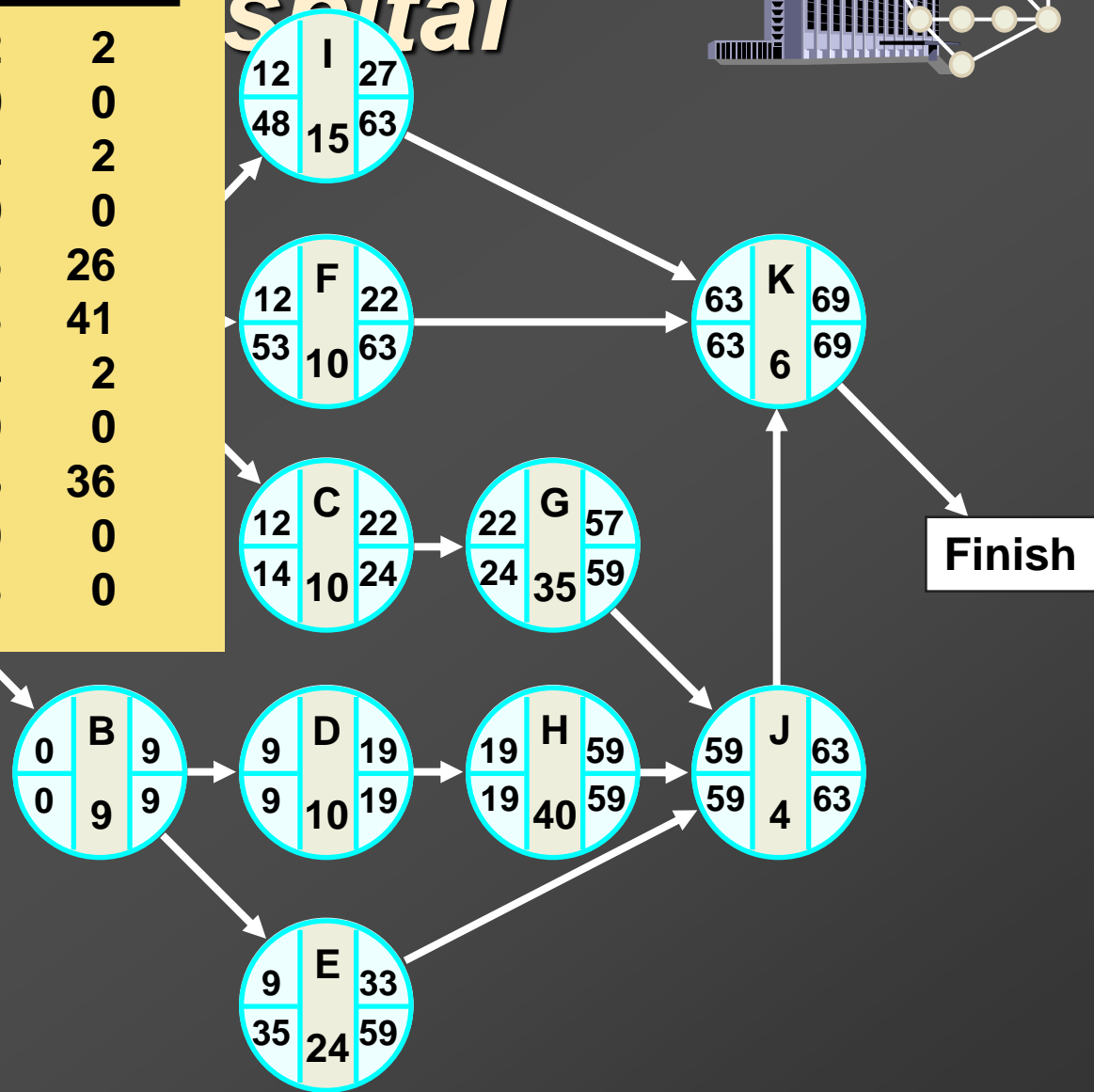
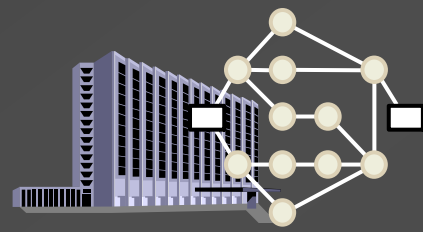

Activity Slack Analysis

Node Duration ES LS Slack

Node	Duration	ES	LS	Slack
A	12	0	2	2
B	9	0	0	0
C	10	12	14	2
D	10	9	9	0
E	24	9	35	26
F	10	12	53	41
G	35	22	24	2
H	40	19	19	0
I	15	12	48	36
J	4	59	59	0
K	6	63	63	0

critical

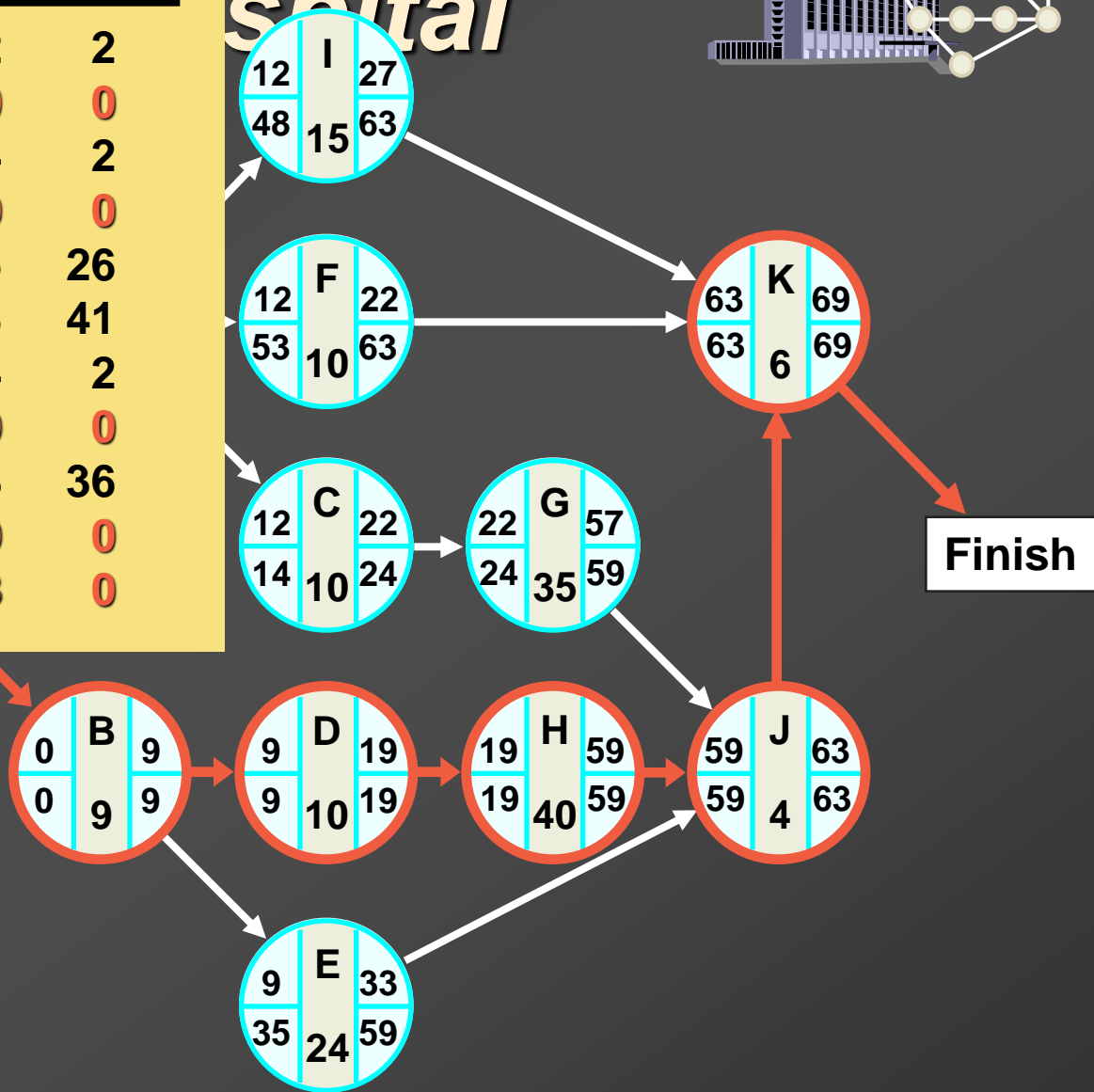
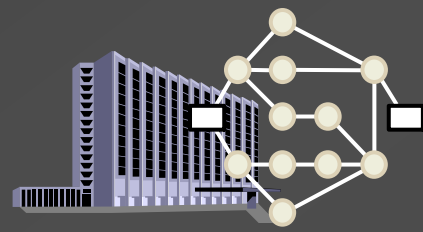

Critical Path

St. Adolf's Hospital

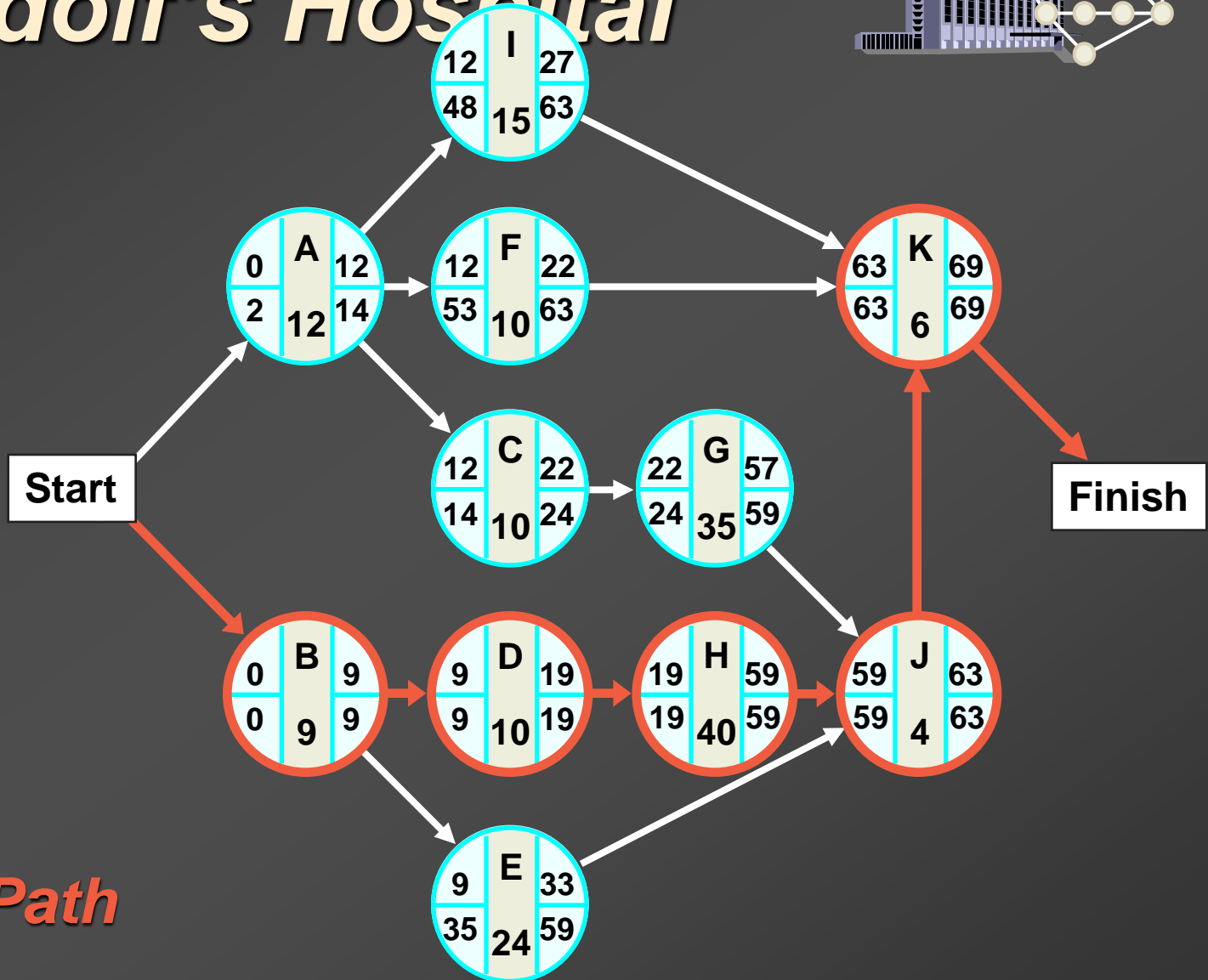
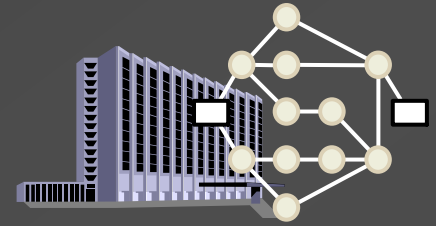

Critical Path

St. Adolf's Hospital

Cost-Time Relationships in Cost Analysis

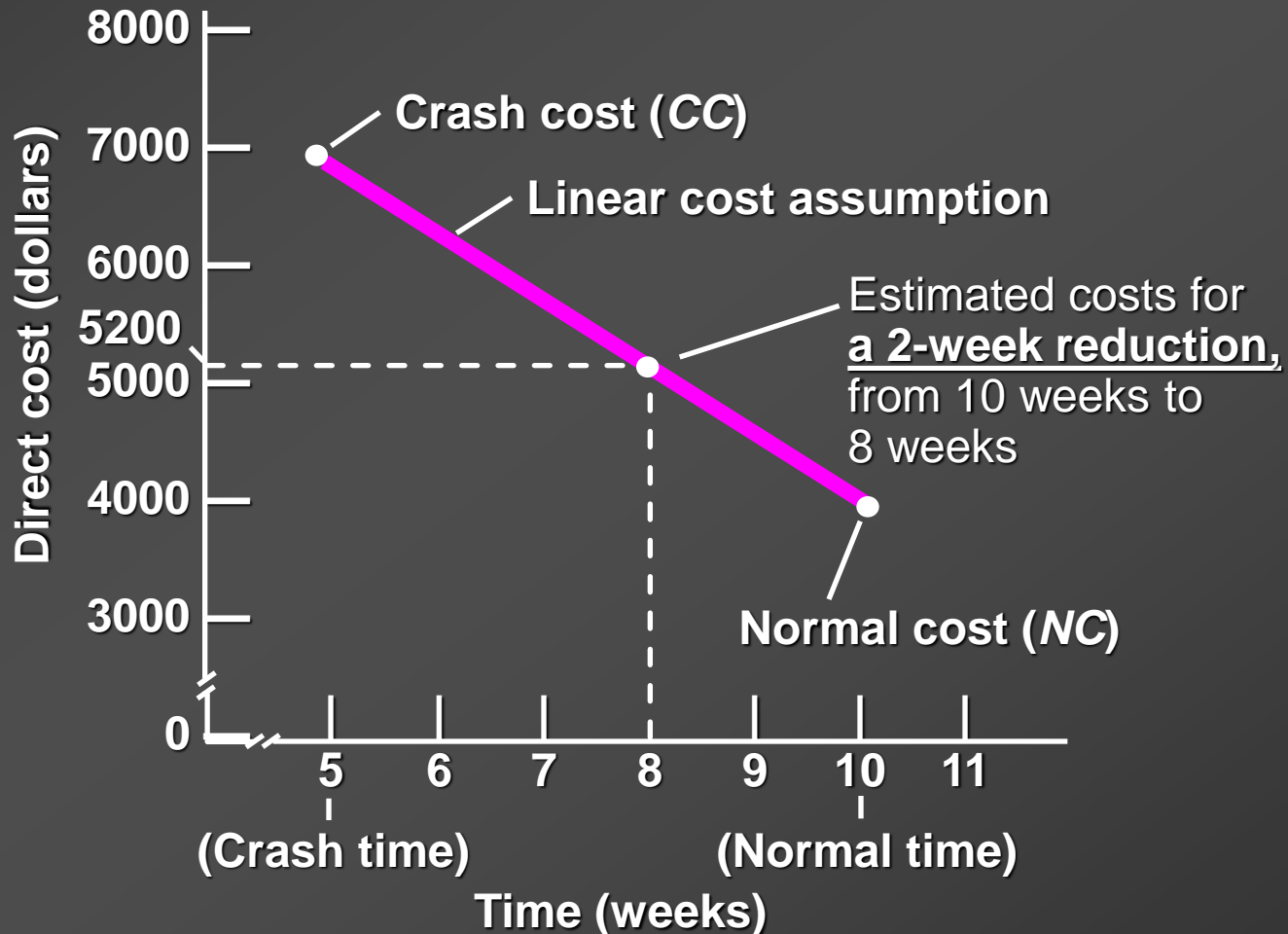
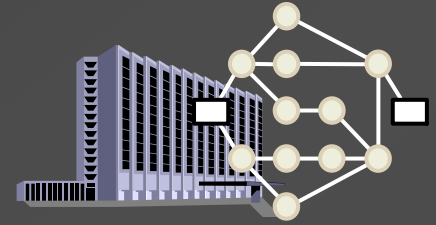

St. Adolf's Hospital

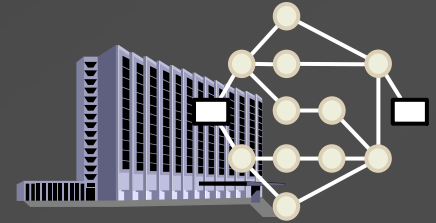
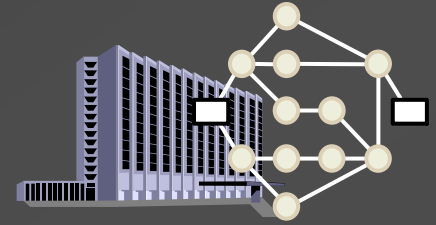

TABLE 8.1 DIRECT COST AND TIME DATA FOR THE ST. ADOLF'S HOSPITAL PROJECT

Activity	Normal Time (NT)	Normal Cost (NC)	Crash Time (CT)	Crash Cost (CC)	Maximum Time Reduction (wk)	Cost of Crashing per Week
A	12	\$ 12,000	11	\$ 13,000	1	\$ 1,000
B	9	50,000	7	64,000	2	7,000
C	10	4,000	5	7,000	5	600
D	10	16,000	8	20,000	2	2,000
E	24	120,000	14	200,000	10	8,000
F	10	10,000	6	16,000	4	1,500
G	35	500,000	25	530,000	10	3,000
H	40	1,200,000	35	1,260,000	5	12,000
I	15	40,000	10	52,500	5	2,500
J	4	10,000	1	13,000	2	1,000
K	6	30,000	5	34,000	1	4,000
Totals		\$1,992,000		\$2,209,000		

St. Adolf's Hospital



Minimum-Cost Schedule

A-H-K:	33 weeks	B-D-H-J-K:	69 weeks
A-F-K:	28 weeks	B-E-J-K:	43 weeks
A-C-G-J-K:	67 weeks		

Total cost = \$2,624,000

Indirect costs = \$8,000/week

Penalty cost = \$20,000/week after week 65

Critical Path B-D-H-J-K: 69 weeks

Crash Activity J by 3 weeks @ \$1,000/week

St. Adolf's Hospital

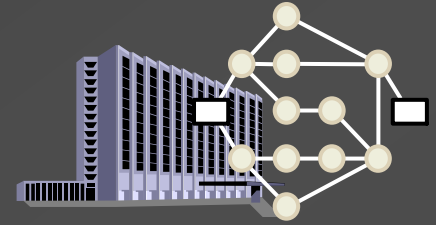

Minimum-Cost Schedule

A-H-K:	33 weeks	B-D-H-J-K:	69 weeks
A-F-K:	28 weeks	B-E-J-K:	43 weeks
A-C-G-J-K:	67 weeks		

Total cost = \$2,624,000

Indirect costs = \$8,000/week

Penalty cost = \$20,000/week after week 65

Critical Path B-D-H-J-K: 69 weeks

Crash Activity J by 3 weeks @ \$1,000/week

$$3(\$28,000) - 3(\$1,000) = \$81,000$$

St. Adolf's Hospital

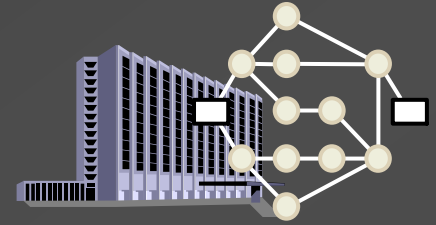

Minimum-Cost Schedule

~~A-H-K:~~ 33 weeks

B-D-H-J-K: 69 weeks

~~A-F-K:~~ 28 weeks

~~B-E-J-K:~~ 43 weeks

A-C-G-J-K: 67 weeks

Total cost = \$2,624,000

Indirect costs = \$8,000/week

Penalty cost = \$20,000/week after week 65

Critical Path B-D-H-J-K: 66 weeks

Crash Activity J by 3 weeks @ \$1,000/week

$$3(\$28,000) - 3(\$1,000) = \$81,000$$

$$\$2,624,000 - \$81,000 = \$2,543,000$$

St. Adolf's Hospital

Minimum-Cost Schedule

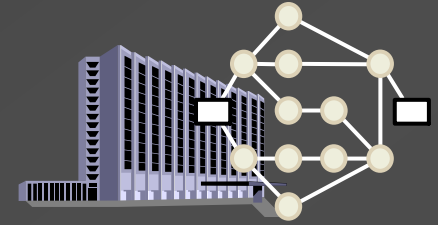

~~A-H-K:~~ 33 weeks

B-D-H-J-K: 69 weeks

~~A-F-K:~~ 28 weeks

~~B-E-J-K:~~ 43 weeks

A-C-G-J-K: 67 weeks

Total cost = ~~\$2,624,000~~ \$2,543,000

Indirect costs = \$8,000/week

Penalty cost = \$20,000/week after week 65

Critical Path B-D-H-J-K: 66 weeks

Crash Activity J by 3 weeks @ \$1,000/week

$$3(\$28,000) - 3(\$1,000) = \$81,000$$

$$\$2,624,000 - \$81,000 = \$2,543,000$$

St. Adolf's Hospital

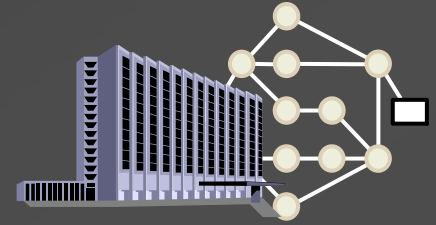

Minimum

A-I-K:

A-F-K:

A-C-G-J-K:

Total Cost

Indirect Cost

Penalty

Critical Path

Crash Activity

3(\$2800)

\$2,620

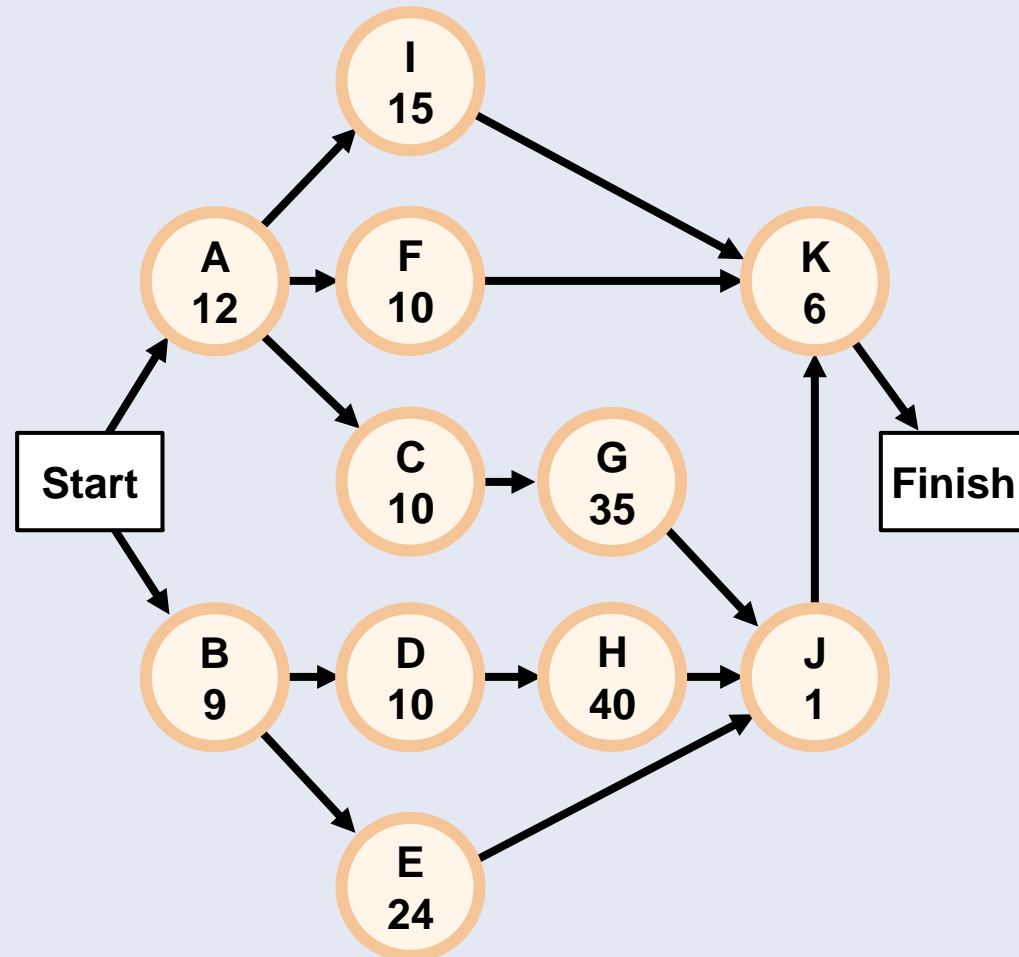



St. Ado

Minimum Cost

A-I-K:

A-F-K:

A-C-G-J-K:

Total cost

Indirect

Penalty

Critical Path

Crash Activity

3(\$28,000)

\$2,624,000

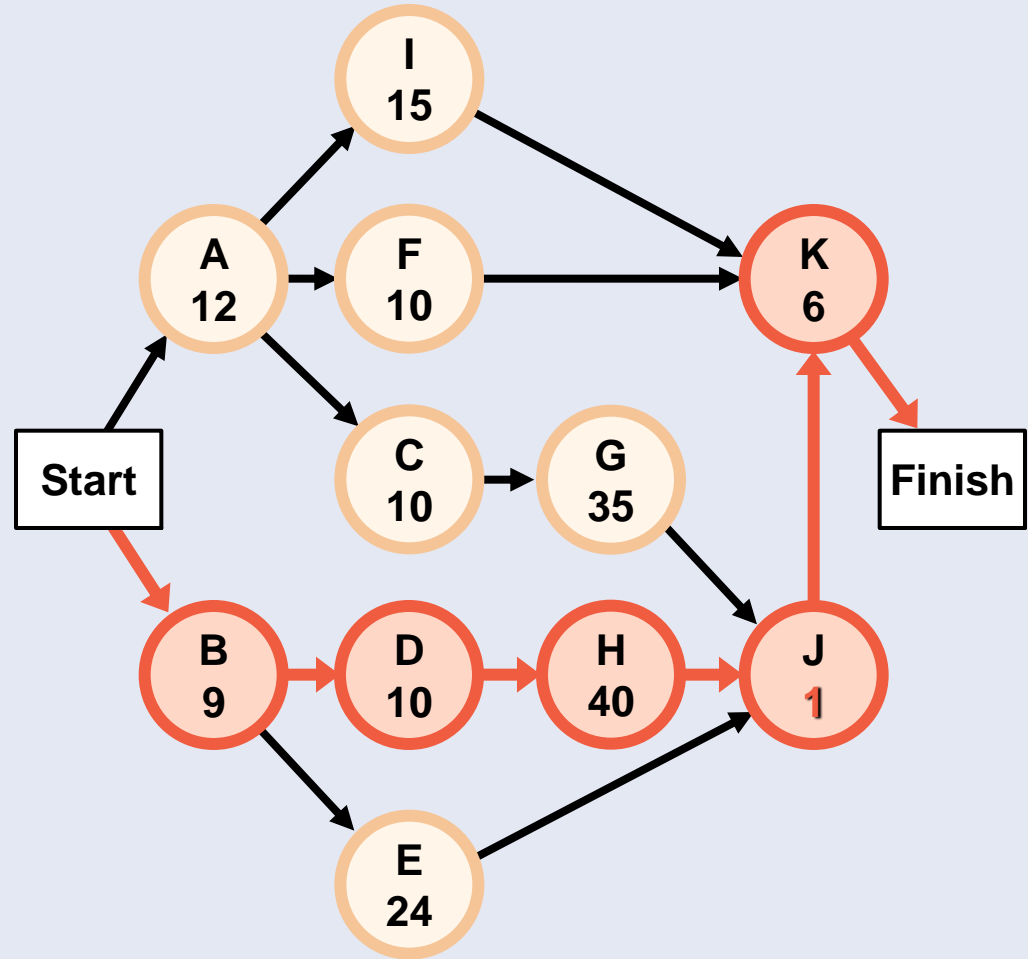

St. Adolf's Hospital

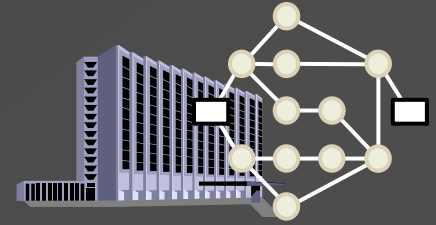

Minimum-Cost Schedule

A-H-K:	33 weeks	B-D-H-J-K:	69 weeks
A-F-K:	28 weeks	B-E-J-K:	43 weeks
A-C-G-J-K:	67 weeks		

Total cost = ~~\$2,624,000~~ \$2,543,000

Indirect costs = \$8,000/week

Penalty cost = \$20,000/week after week 65

Critical Path B-D-H-J-K: 66 weeks

Crash Activity D by 2 weeks @ \$2,000/week

St. Adolf's Hospital

Minimum-Cost Schedule

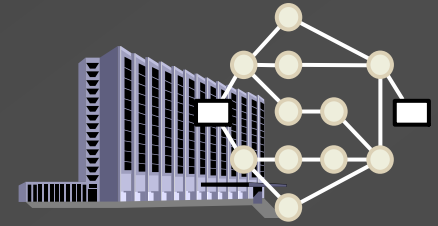

~~A-H-K:~~ 33 weeks

B-D-H-J-K: 69 weeks

~~A-F-K:~~ 28 weeks

~~B-E-J-K:~~ 43 weeks

A-C-G-J-K: 67 weeks

Total cost = ~~\$2,624,000~~ \$2,543,000

Indirect costs = \$8,000/week

Penalty cost = \$20,000/week after week 65

Critical Path B-D-H-J-K: 66 weeks

Crash Activity D by 2 weeks @ \$2,000/week

$$\$28,000 + \$8,000 - 2(\$2,000) = \$32,000$$

$$\$2,543,000 - \$32,000 = \$2,511,000$$

St. Adolf's Hospital

Minimum-Cost Schedule

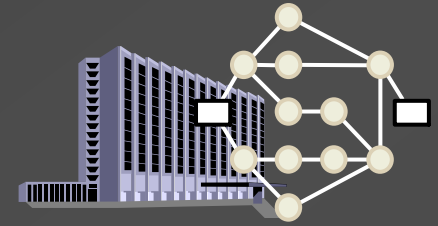

~~A-H-K:~~ 33 weeks

B-D-H-J-K: 69 weeks

~~A-F-K:~~ 28 weeks

~~B-E-J-K:~~ 43 weeks

A-C-G-J-K: 67 weeks

Total cost = ~~\$2,624,000~~ \$2,511,000

Indirect costs = \$8,000/week

Penalty cost = \$20,000/week after week 65

Critical Path B-D-H-J-K: 64 weeks

Crash Activity D by 2 weeks @ \$2,000/week

$$\$28,000 + \$8,000 - 2(\$2,000) = \$32,000$$

$$\$2,543,000 - \$32,000 = \$2,511,000$$



St. Ado

Minimum-C

~~A-I-K:~~

~~A-F-K:~~

A-C-G-J-K

Total c

Indirect

Penalty

Critical Pa

Crash Ac

\$28,00

\$2,543

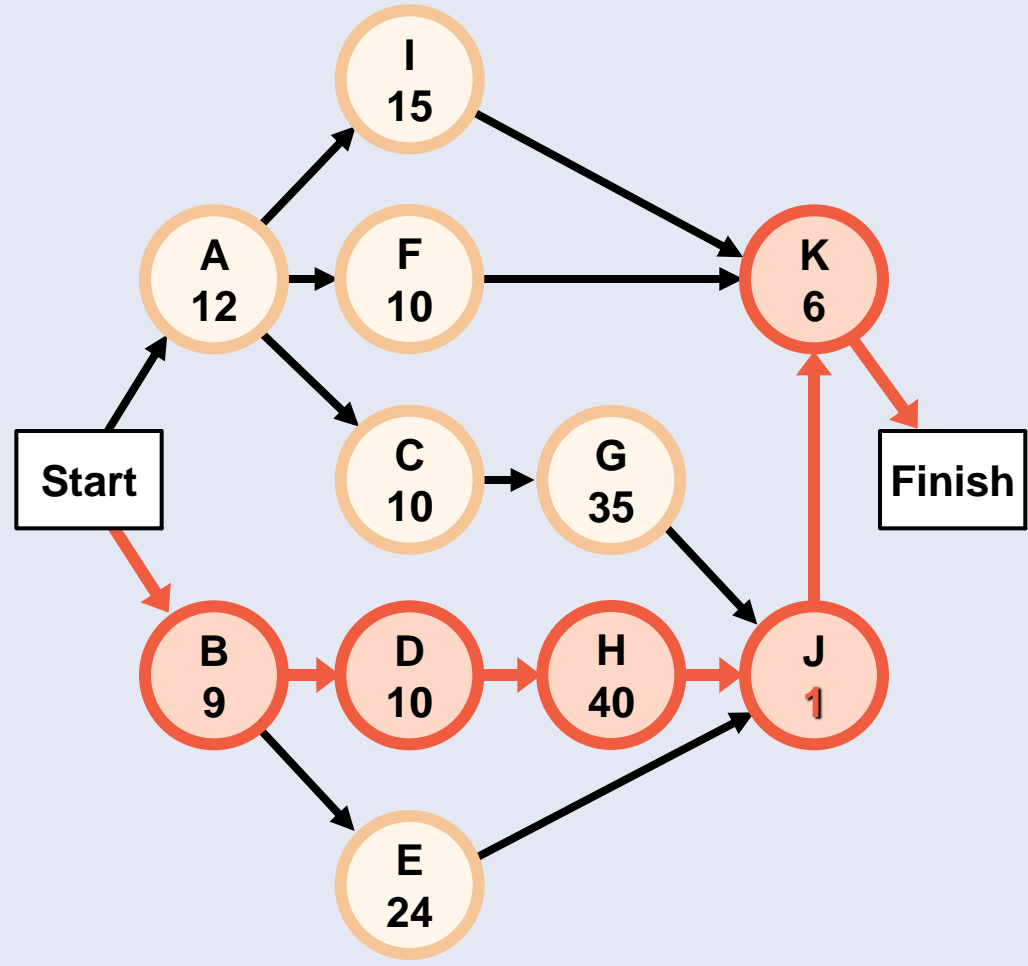



St. Ado

Minimum-C

~~A-I-K:~~

~~A-F-K:~~

A-C-G-J-K

Total c

Indirect

Penalty

Critical Pa

Crash Ac

\$28,00

\$2,543

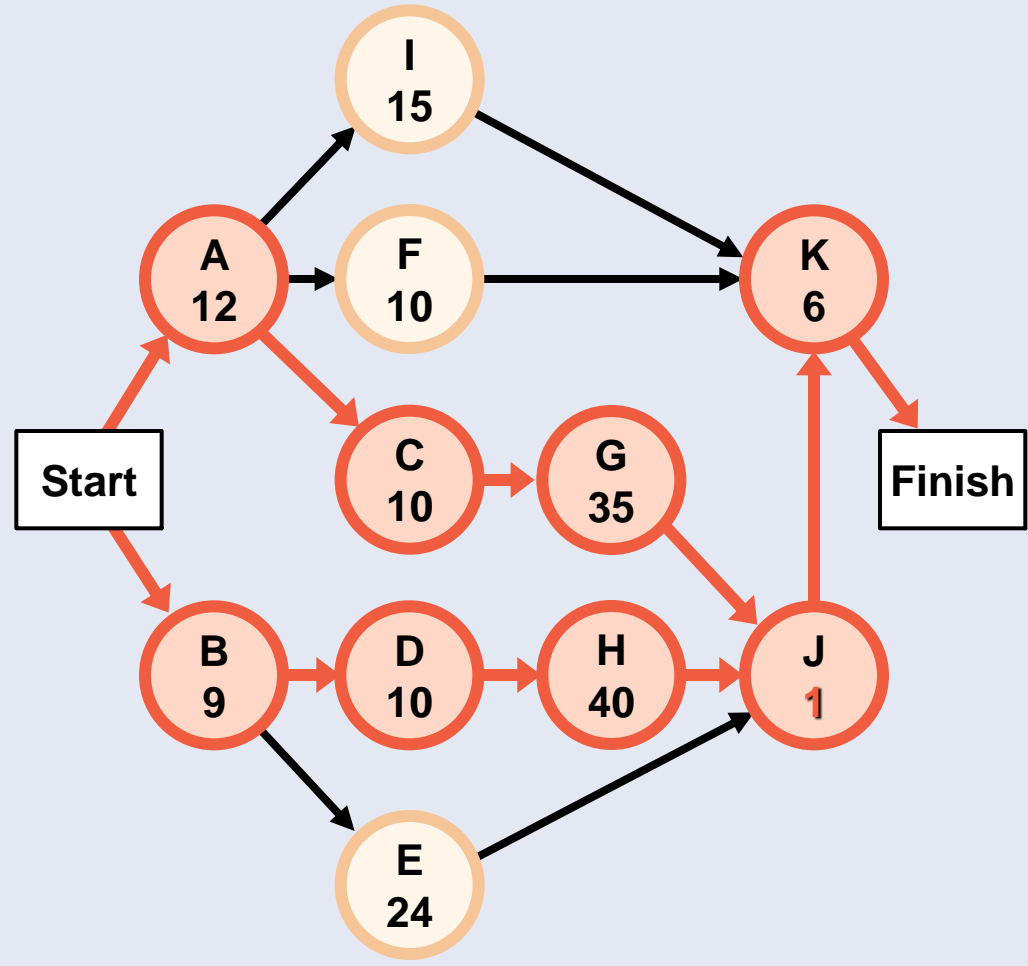

St. Adolf's Hospital

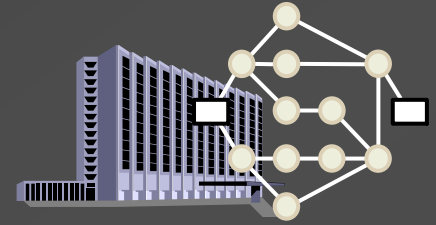

Minimum-Cost Schedule

A-F-K:	33 weeks	B-D-H-J-K:	69 weeks
A-F-K:	28 weeks	B-E-J-K:	43 weeks
A-C-G-J-K:	67 weeks		

Total cost = ~~\$2,624,000~~ \$2,511,000

Indirect costs = \$8,000/week

Penalty cost = \$20,000/week after week 65

Critical Paths B-D-H-J-K and A-C-G-J-K: 64 weeks

Crash Activity K by 1 week @ \$4,000/week

St. Adolf's Hospital

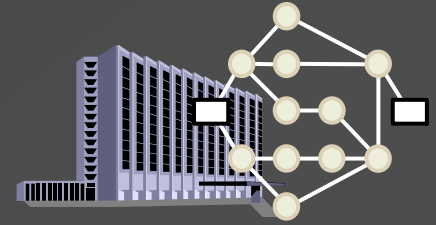

Minimum-Cost Schedule

A-H-K:	33 weeks	B-D-H-J-K:	69 weeks
A-F-K:	28 weeks	B-E-J-K:	43 weeks
A-C-G-J-K:	67 weeks		

Total cost = ~~\$2,624,000~~ \$2,511,000

Indirect costs = \$8,000/week

Penalty cost = \$20,000/week after week 65

Critical Paths B-D-H-J-K and A-C-G-J-K: 64 weeks

Crash Activity K by 1 week @ \$4,000/week

$$\$8,000 - \$4,000 = \$4,000$$

$$\$2,511,000 - \$4,000 = \$2,507,000$$

St. Adolf's Hospital

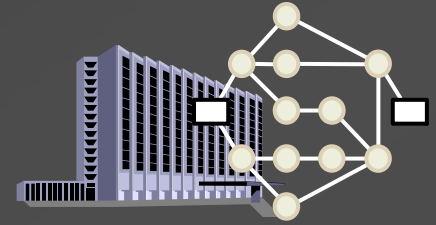

Minimum-Cost Schedule

A-H-K:	33 weeks	B-D-H-J-K:	69 weeks
A-F-K:	28 weeks	B-E-J-K:	43 weeks
A-C-G-J-K:	67 weeks		

Total cost = ~~\$2,624,000~~ \$2,507,000

Indirect costs = \$8,000/week

Penalty cost = \$20,000/week after week 65

Critical Paths B-D-H-J-K and A-C-G-J-K: 63 weeks

Crash Activity K by 1 week @ \$4,000/week

$$\$8,000 - \$4,000 = \$4,000$$

$$\$2,511,000 - \$4,000 = \$2,507,000$$



St. Ado

Minimum-C

~~A-I-K:~~

~~A-F-K:~~

A-C-G-J-K

Total c

Indirect

Penalty

Critical Pa

Crash Ac

\$8,000

\$2,511

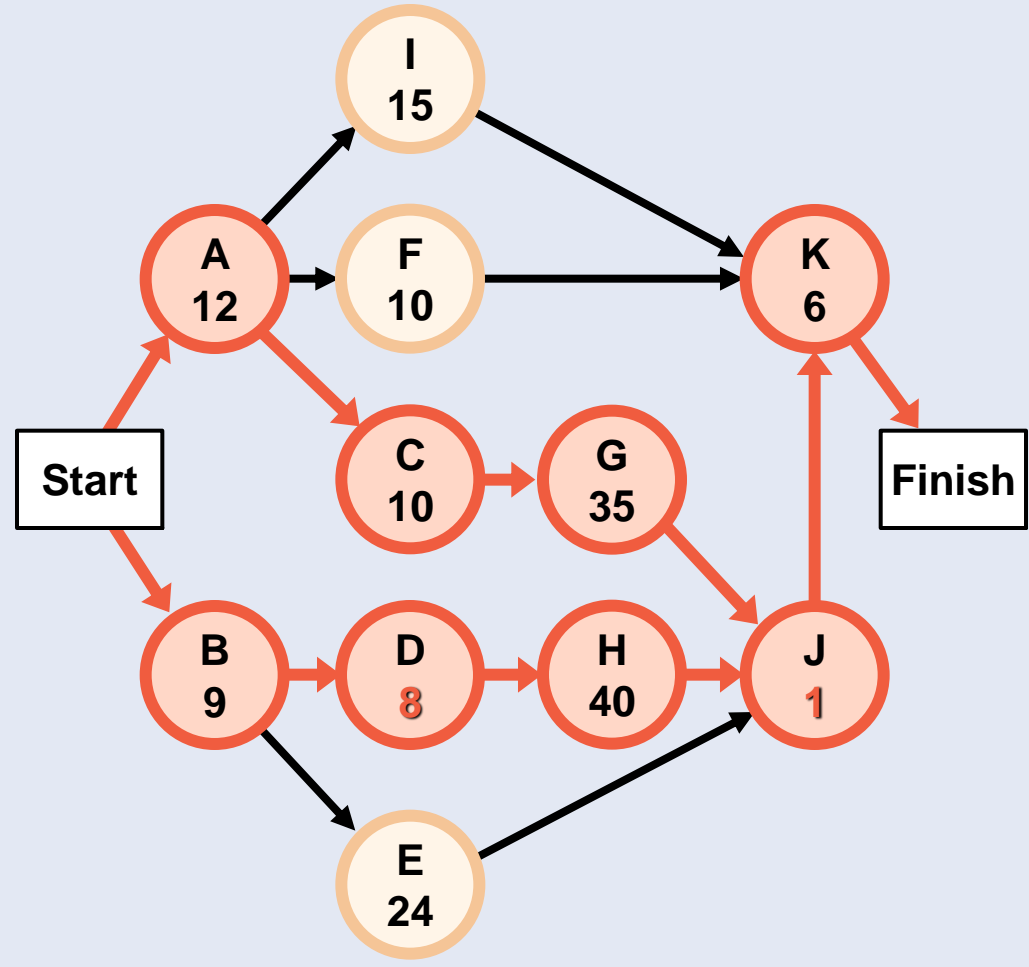



St. Ado

Minimum-C

~~A-I-K:~~

~~A-F-K:~~

A-C-G-J-K

Total c

Indirect

Penalty

Critical Pa

Crash Ac

\$8,000

\$2,511

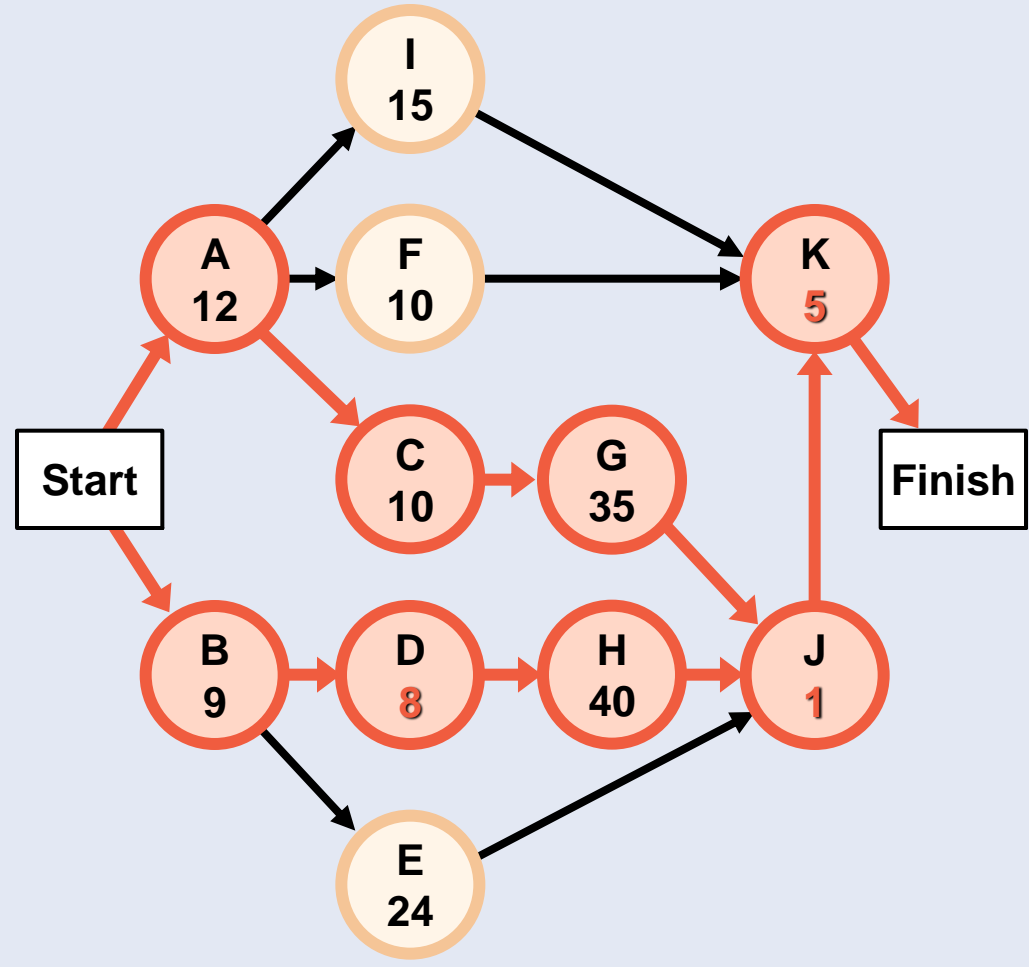

St. Adolf's Hospital

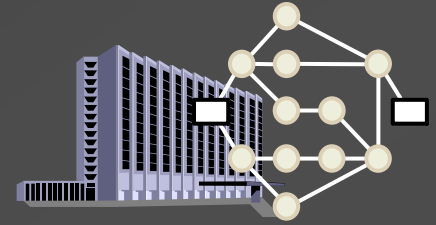

Minimum-Cost Schedule

A-I-K:	33 weeks	B-D-H-J-K:	69 weeks
A-F-K:	28 weeks	B-E-J-K:	43 weeks
A-C-G-J-K:	67 weeks		

Total cost = ~~\$2,624,000~~ \$2,507,000

Indirect costs = \$8,000/week

Penalty cost = \$20,000/week after week 65

Critical Paths B-D-H-J-K and A-C-G-J-K: 63 weeks

Crash Activities B and C by 2 weeks

@ \$7,000/week and \$600/week

St. Adolf's Hospital

Minimum-Cost Schedule

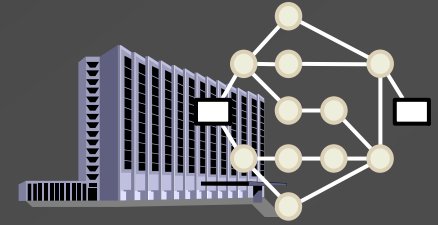

~~A-H-K:~~ 33 weeks

B-D-H-J-K: 69 weeks

~~A-F-K:~~ 28 weeks

~~B-E-J-K:~~ 43 weeks

A-C-G-J-K: 67 weeks

Total cost = ~~\$2,624,000~~ \$2,507,000

Indirect costs = \$8,000/week

Penalty cost = \$20,000/week after week 65

Critical Paths B-D-H-J-K and A-C-G-J-K: 63 weeks

Crash Activities B and C by 2 weeks

@ \$7,000/week and \$600/week

$$2(\$8,000) - 2(\$7,600) = \$800$$

$$\$2,507,000 - \$800 = \$2,506,200$$

St. Adolf's Hospital

Minimum-Cost Schedule

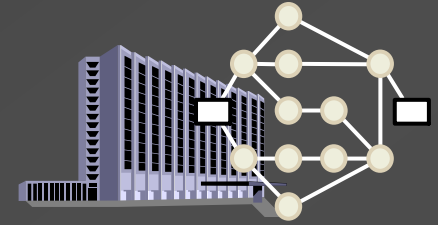

~~A-H-K:~~ 33 weeks

B-D-H-J-K: 69 weeks

~~A-F-K:~~ 28 weeks

~~B-E-J-K:~~ 43 weeks

A-C-G-J-K: 67 weeks

Total cost = ~~\$2,624,000~~ \$2,506,200

Indirect costs = \$8,000/week

Penalty cost = \$20,000/week after week 65

Critical Paths B-D-H-J-K and A-C-G-J-K: 61 weeks

Crash Activities B and C by 2 weeks

@ \$7,000/week and \$600/week

$$2(\$8,000) - 2(\$7,600) = \$800$$

$$\$2,507,000 - \$800 = \$2,506,200$$



St. Ad

Minimum-

~~A-K:~~

~~A-F-K:~~

A-C-G-J-K

Total o

Indirect

Penalt

Critical P

Crash Ac

@ \$7,000

2(\$8,0

$$\$2,507,000 - \$800 = \$2,506,200$$

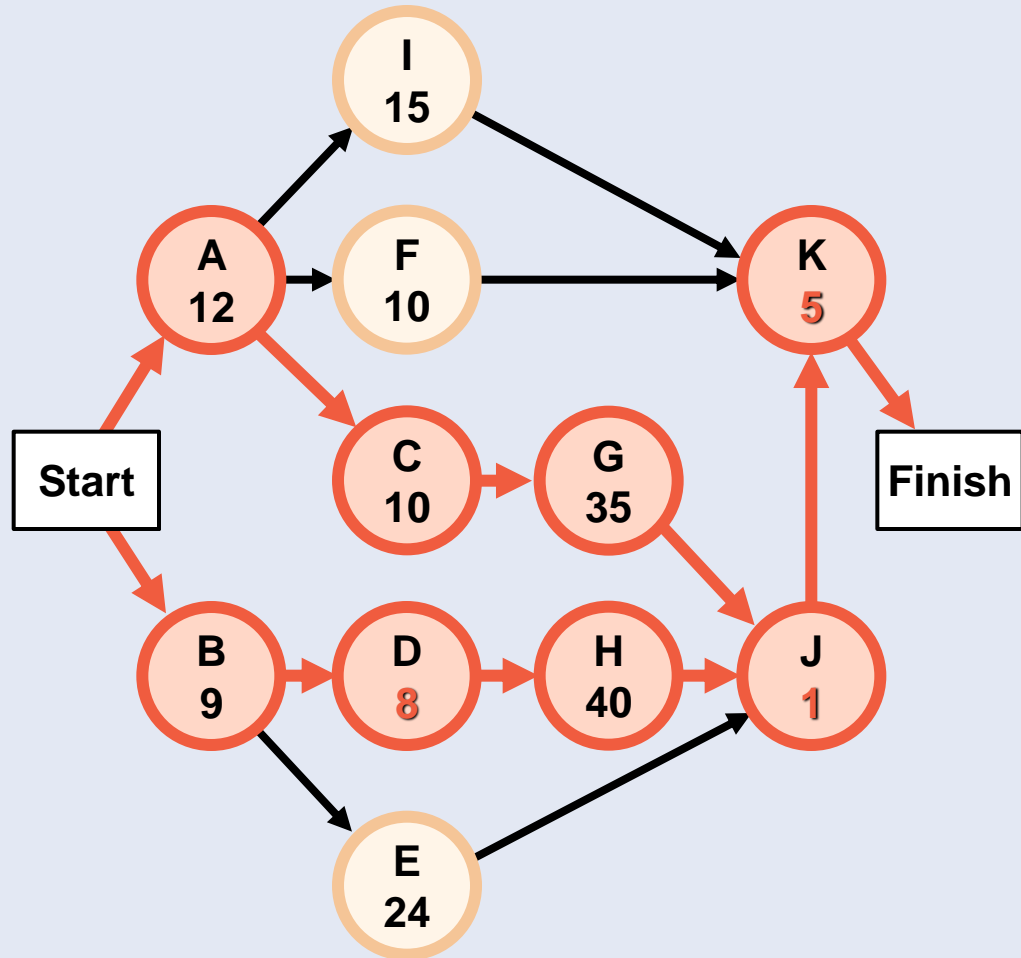



St. Ado

Minimum-

~~A-K:~~

~~A-F-K:~~

A-C-G-J-K

Total o

Indirect

Penalt

Critical P

Crash Ac

@ \$7,000

2(\$8,0

$$\$2,507,000 - \$800 = \$2,506,200$$

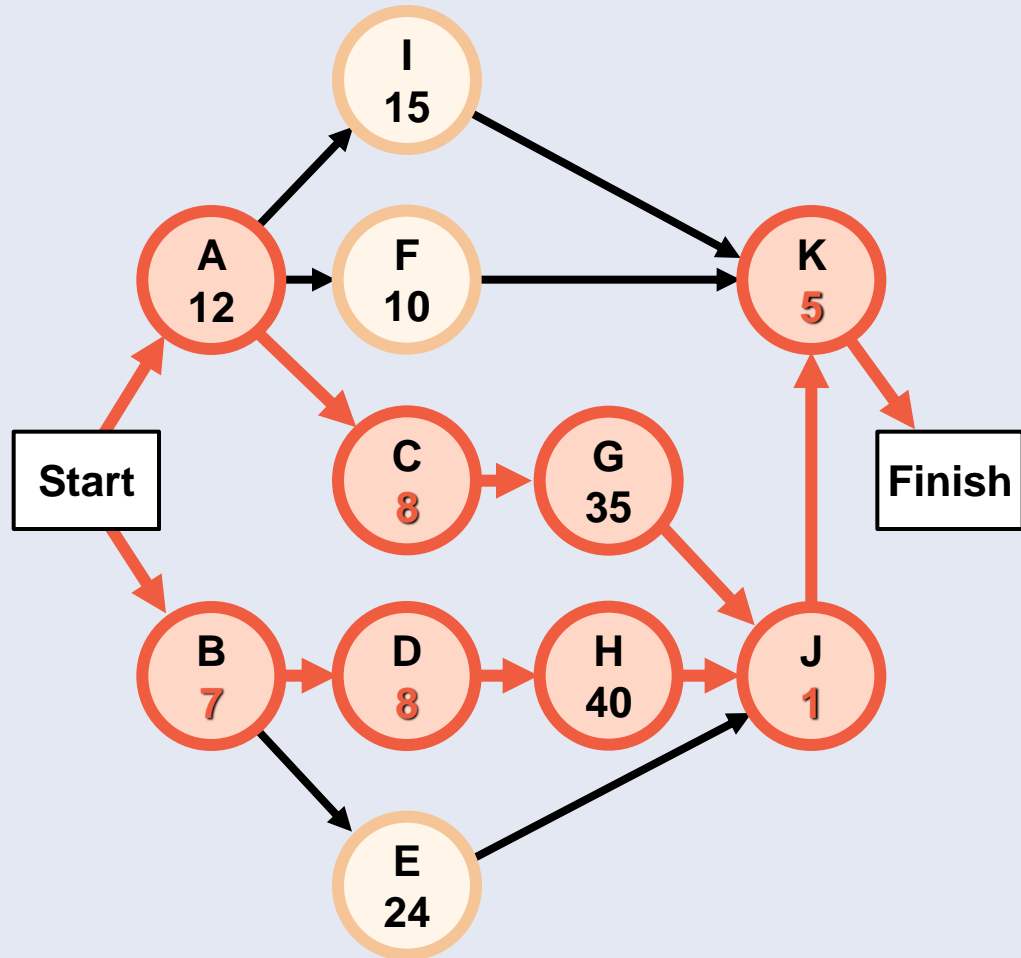

Coors Field



Probabilistic Time Estimates

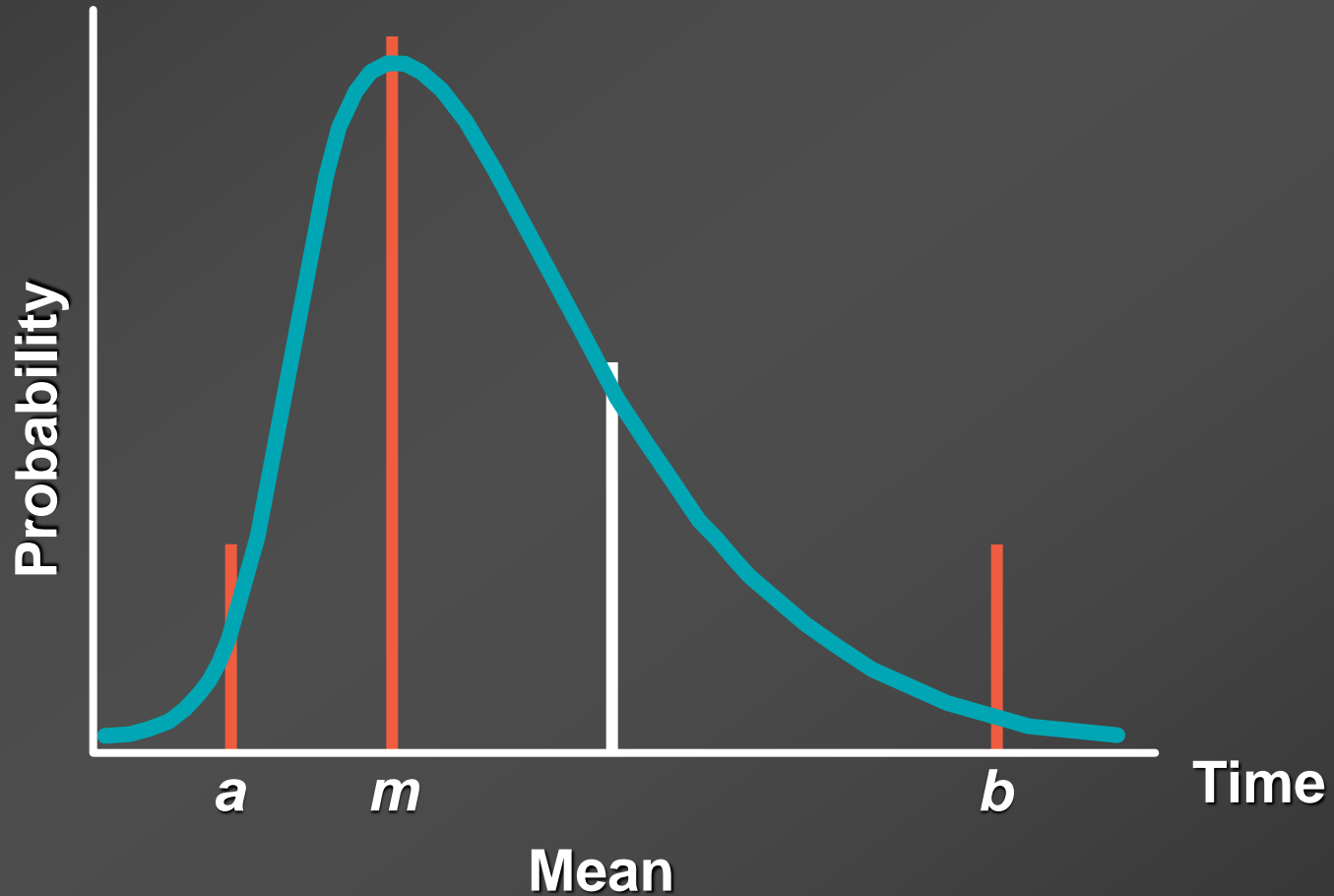
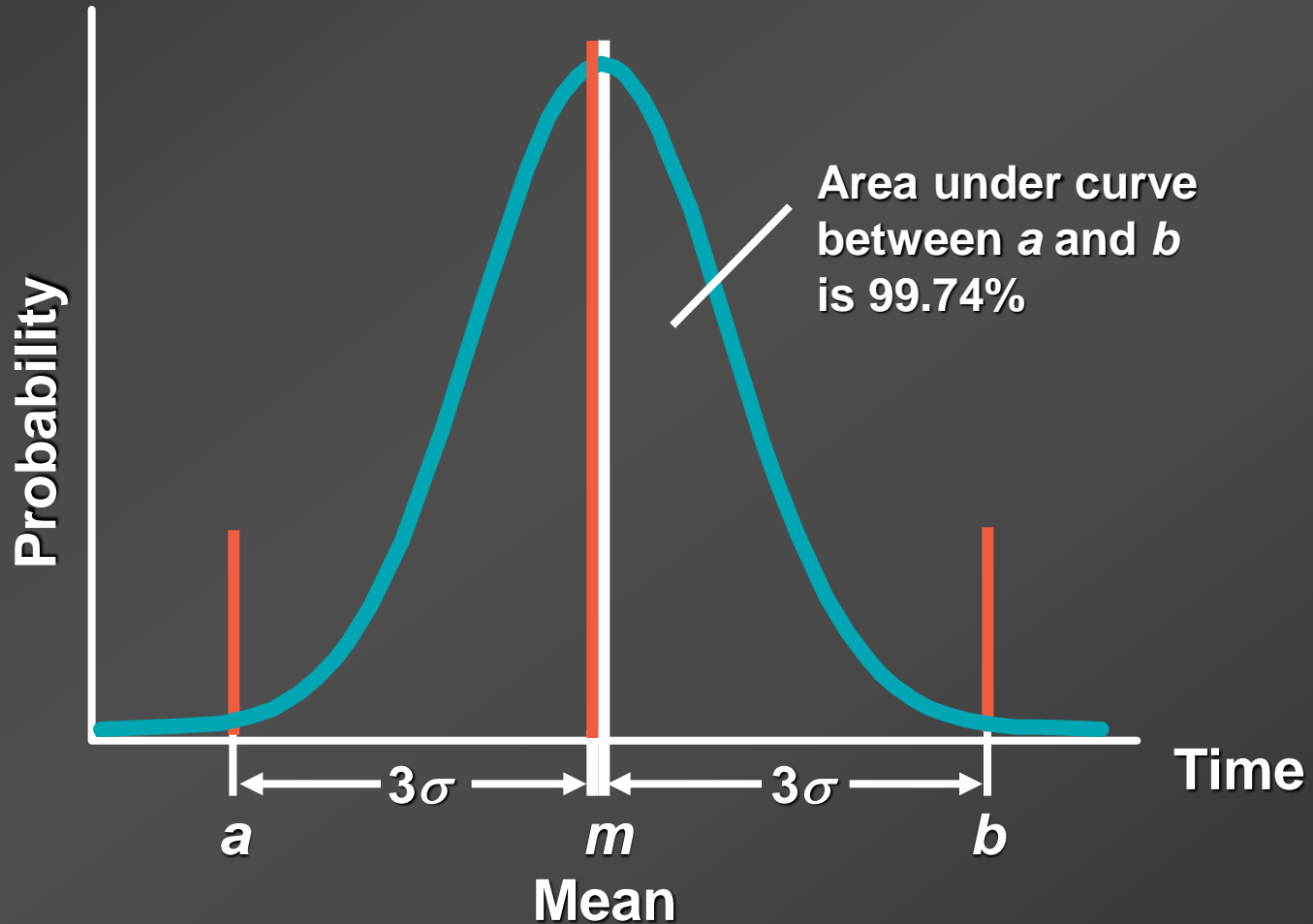

Figure 8.12 (a) Beta Distribution

Probabilistic Time Estimates



) Normal Distribution

St. Adolf's Hospital

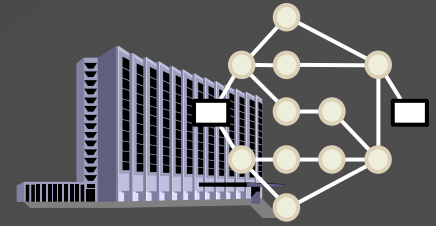

Probabilistic Time Estimates

Mean

$$t_e = \frac{a + 4m + b}{6}$$

Variance

$$\sigma^2 = \left(\frac{b - a}{6} \right)^2$$

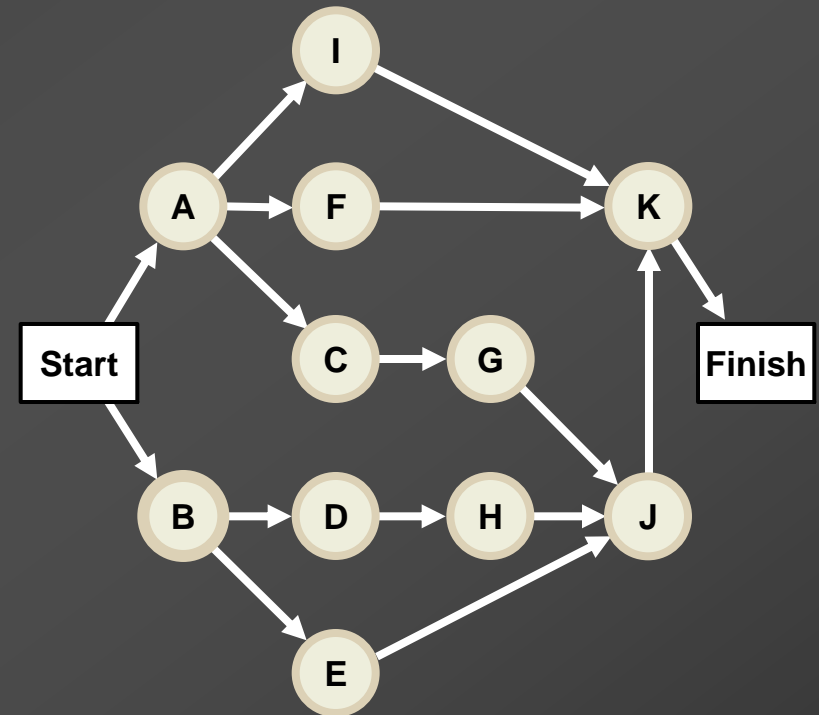

St. Adolf's Hospital

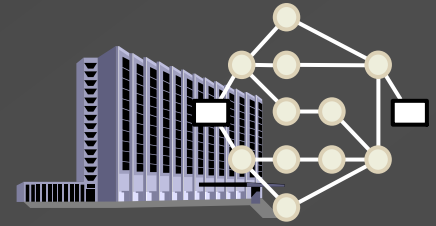

Probabilistic Time Estimates

	Activity B		
	Most Likely		
Optimistic	(<i>m</i>)	Pessimistic	
(<i>a</i>)	(<i>m</i>)	(<i>b</i>)	
7	8	15	

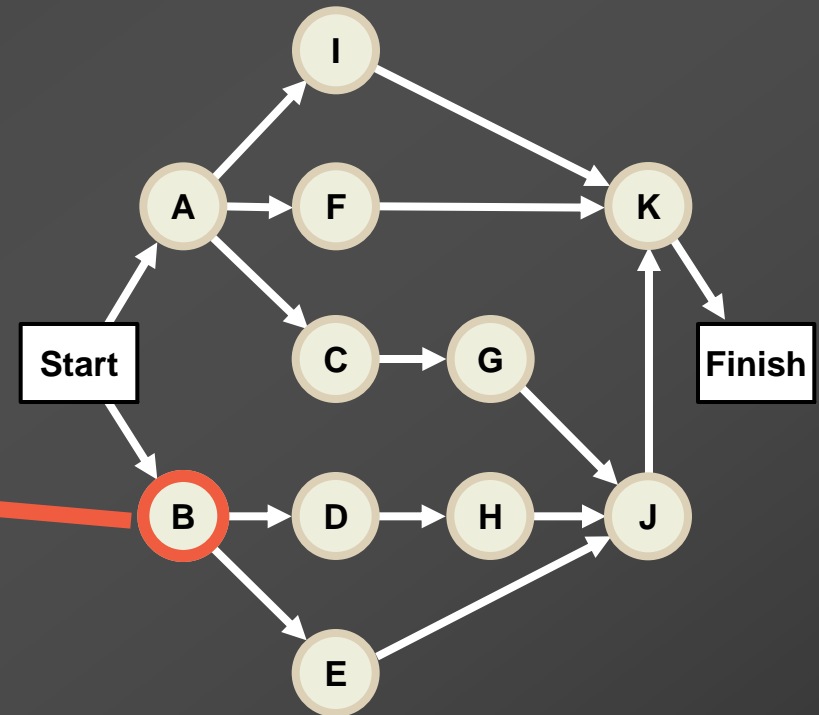

St. Adolf's Hospital

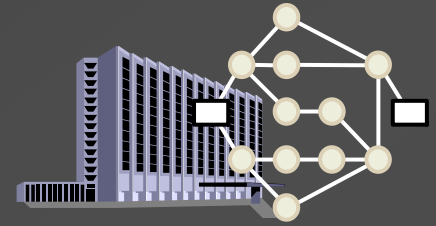

Probabilistic Time Estimates

Activity B		
Optimistic	Most Likely	Pessimistic
(a)	(m)	(b)
7	8	15

$$t_e = \frac{7 + 4(8) + 15}{6} = 9 \text{ weeks}$$

$$\sigma^2 = \left(\frac{15 - 7}{6} \right)^2 = 1.78$$

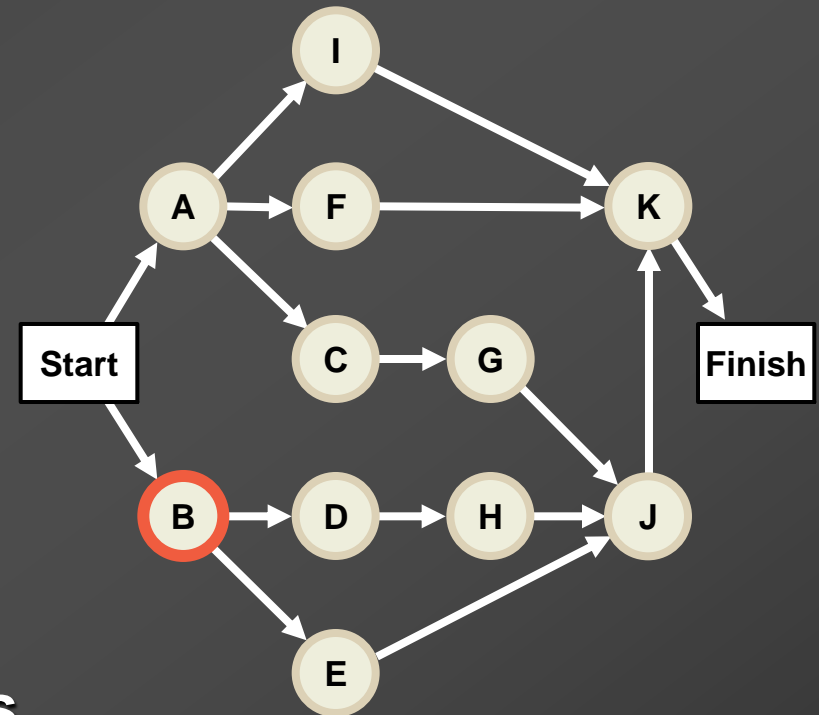

St. Adolf's Hospital

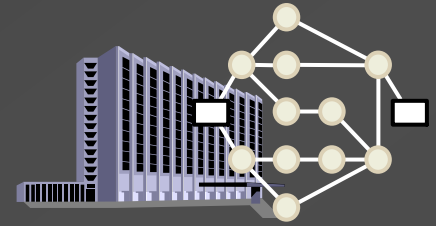

Activity	Time Estimates (wk)			Activity Statistics	
	Optimistic (a)	Likely (m)	Pessimistic (b)	Expected Time (t_e)	Variance (σ^2)
A	11	12	13	12	0.11
B	7	8	15	9	1.78
C	5	10	15	10	2.78
D	8	9	16	10	1.78
E	14	25	30	24	7.11
F	6	9	18	10	4.00
G	25	36	41	35	7.11
H	35	40	45	40	2.78
I	10	13	28	15	9.00
J	1	2	15	4	5.44
K	5	6	7	6	0.11

St. Adolf's Hospital

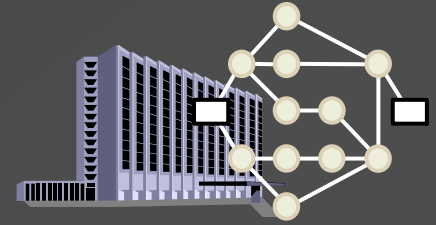

Probabilities

Critical Path = B - D - H - J - K

$T = 72$ days

$T_E = 69$ days

$$\sigma^2 = \sum (\text{variances of activities}) \quad z = \frac{T - T_E}{\sqrt{\sigma^2}}$$

$$\sigma^2 = 1.78 + 1.78 + 2.78 + 5.44 + 0.11 = 11.89$$

$$z = \frac{72 - 69}{\sqrt{11.89}}$$

St. Adolf's Hospital

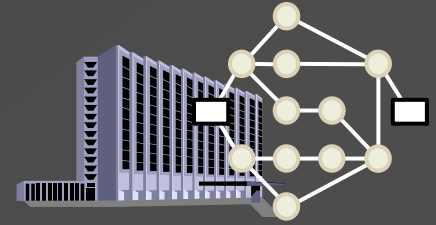

Probabilities

Critical Path = B - D - H - J - K

$T = 72$ days

$T_E = 69$ days

$$\sigma^2 = \sum (\text{variances of activities}) \quad z = \frac{T - T_E}{\sqrt{\sigma^2}}$$

$$\sigma^2 = 1.78 + 1.78 + 2.78 + 5.44 + 0.11 = 11.89$$

$$z = \frac{72 - 69}{\sqrt{11.89}} = 0.87$$

From Appendix 2

$$P_z = .8078 \approx .81$$

St. Adolf's Hospital

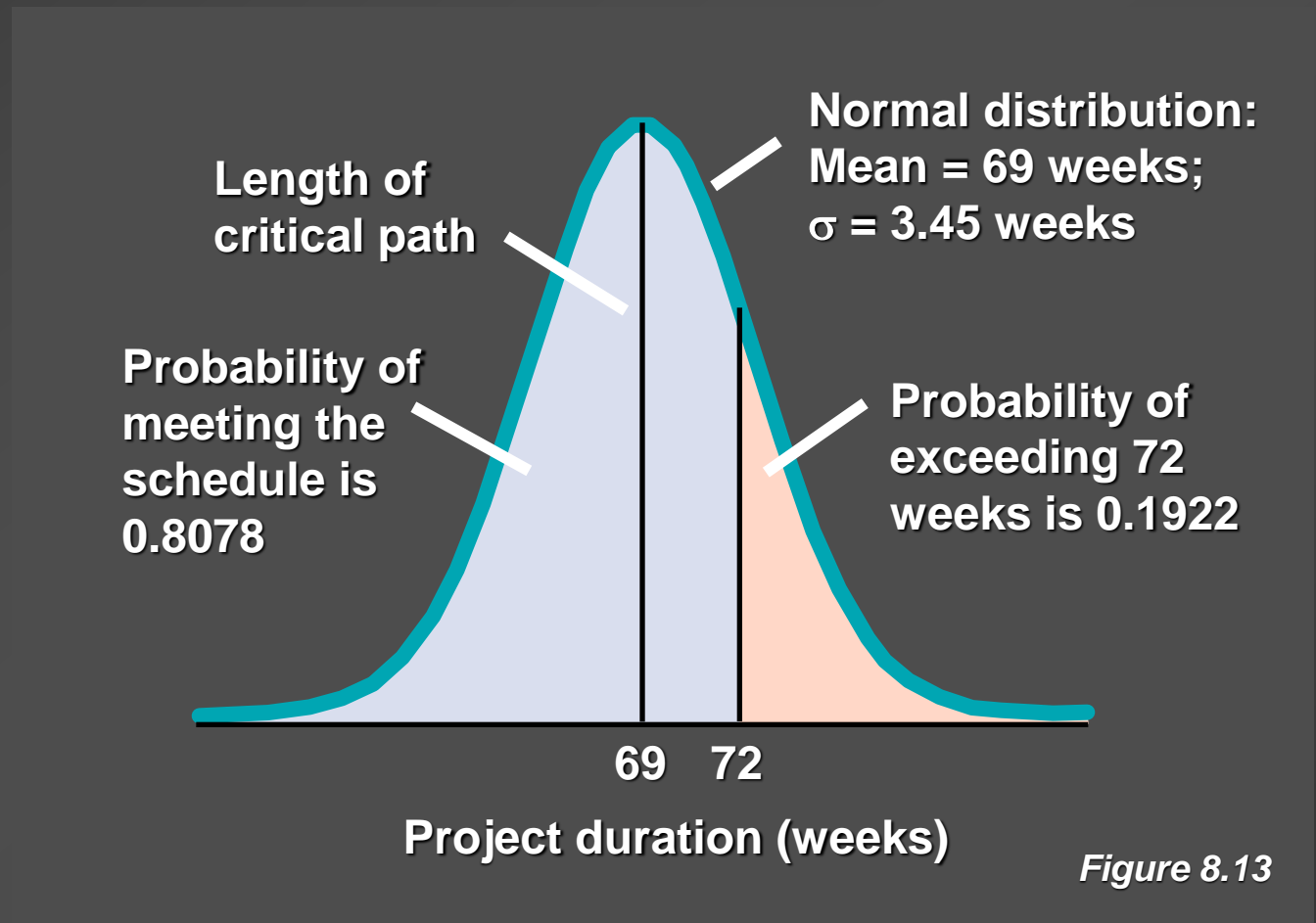
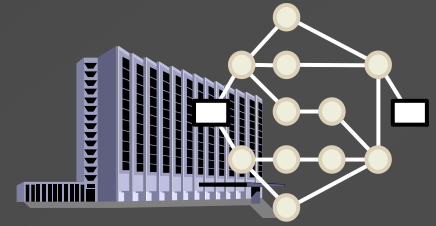

Example 8.7

St. Adolf's Hospital

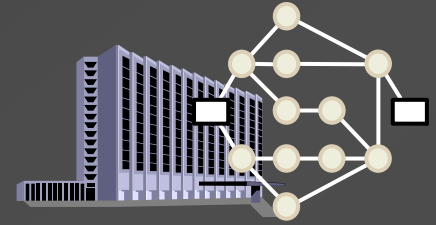

Probabilities

Path = A - C - G - J - K

$T = 72$ days

$T_E = 67$ days

$$\sigma^2 = \sum (\text{variances of activities}) \quad z = \frac{T - T_E}{\sqrt{\sigma^2}}$$

$$\sigma^2 = 0.11 + 2.78 + 7.11 + 5.44 + 0.11 = 15.55$$

$$z = \frac{72 - 67}{\sqrt{15.55}} = 1.27$$

From Appendix 2

$$P_z = .8980 \approx .90$$

St. Adolf's Hospital

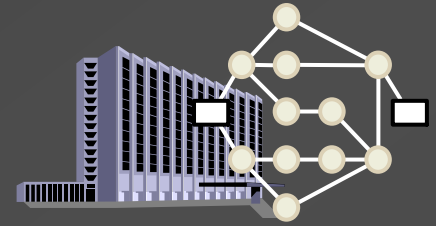
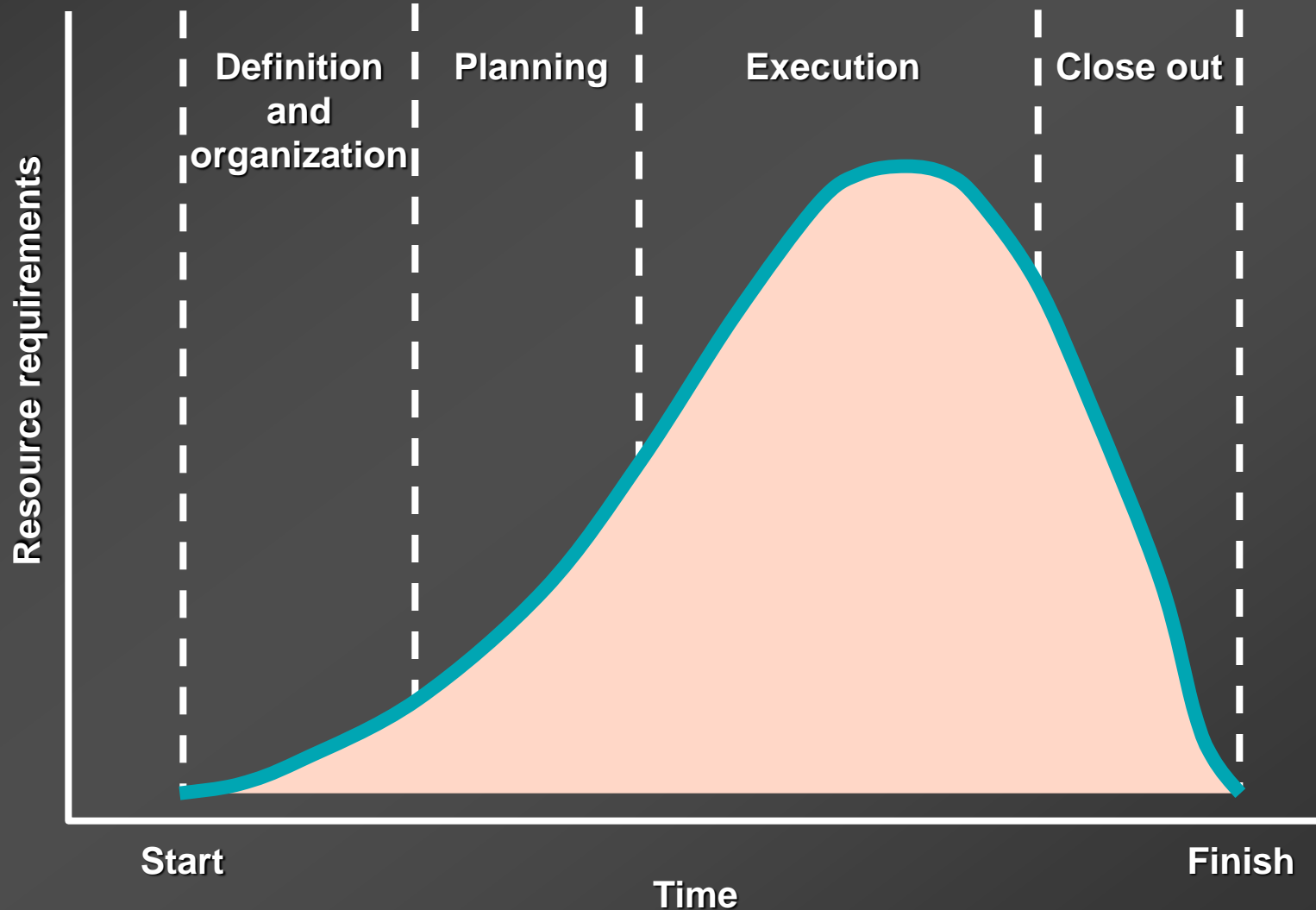

TABLE 8.2 SLACK CALCULATIONS AFTER ACTIVITIES A AND B HAVE BEEN COMPLETED

Activity	Duration	Earliest Start	Latest Start	Slack
C	10	16	14	-2
G	35	26	24	-2
J	4	61	59	-2
K	6	65	63	-2
D	10	10	9	-1
H	40	20	19	-1
E	24	10	35	25
I	15	16	48	32
F	10	16	53	37

Project Life Cycle



Solved Problem 1

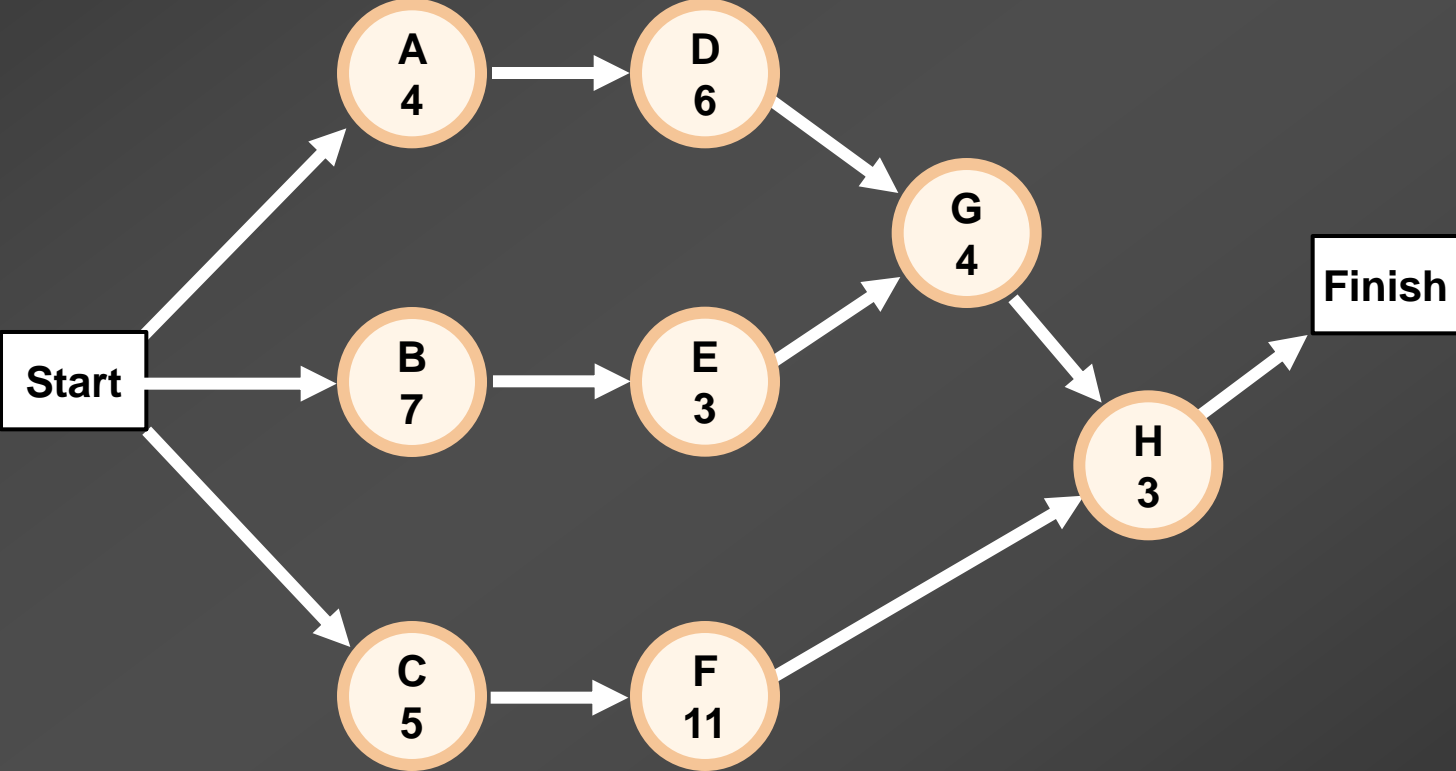

Solved Problem 2

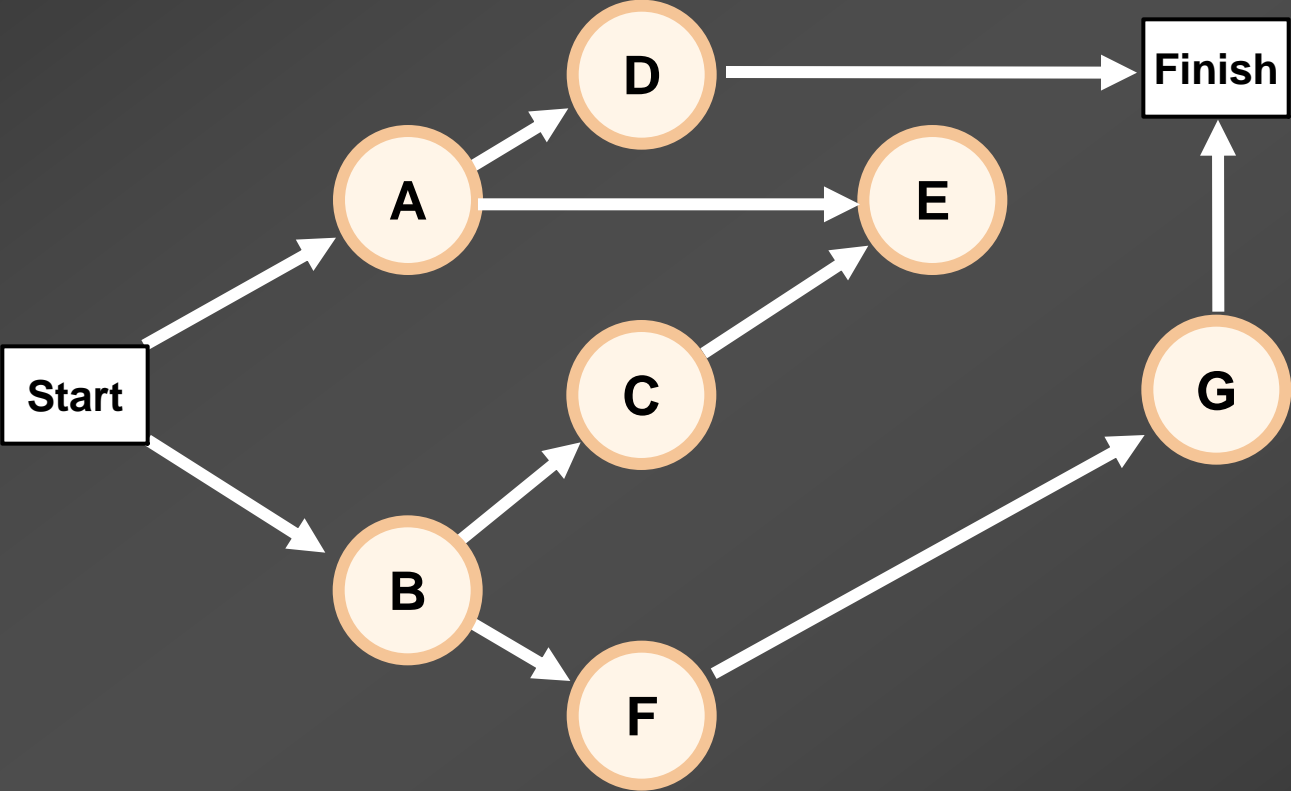

AON Network

Solved Problem 2

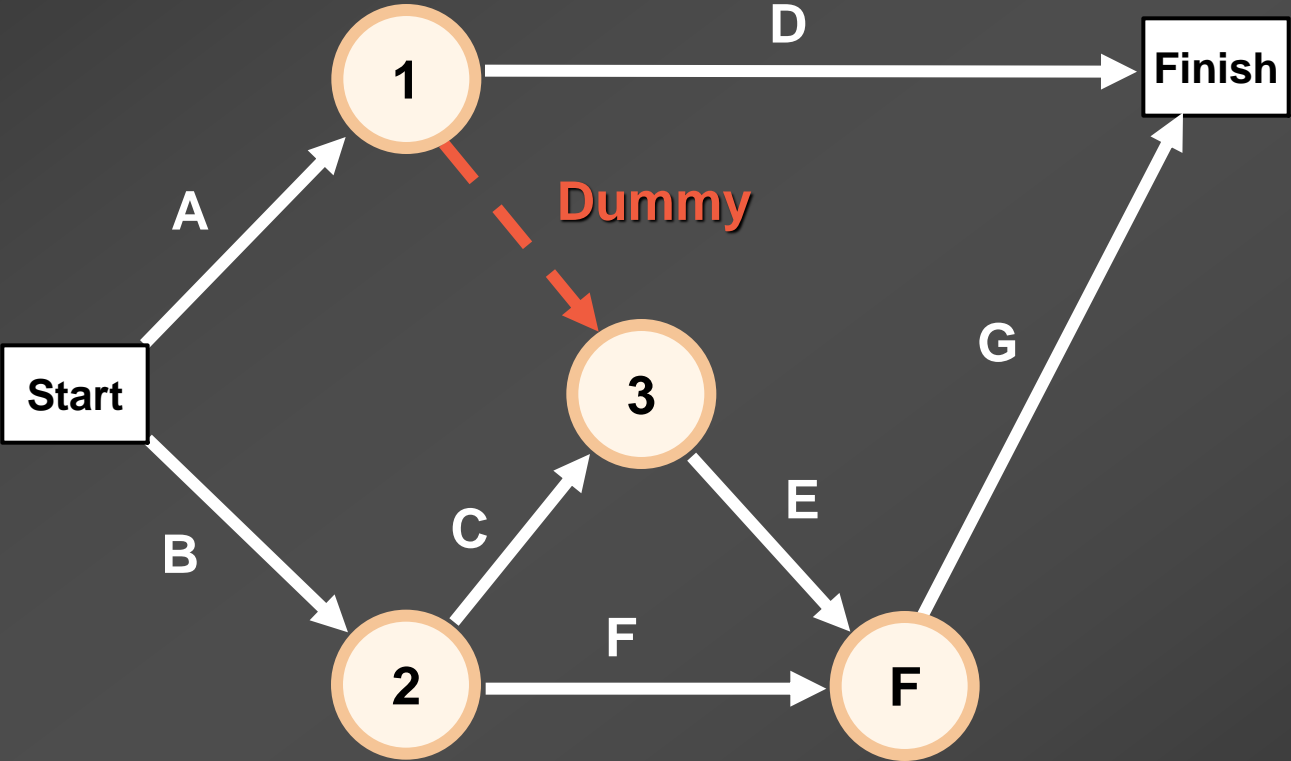

6(b) AOA Network

Solved Problem 2

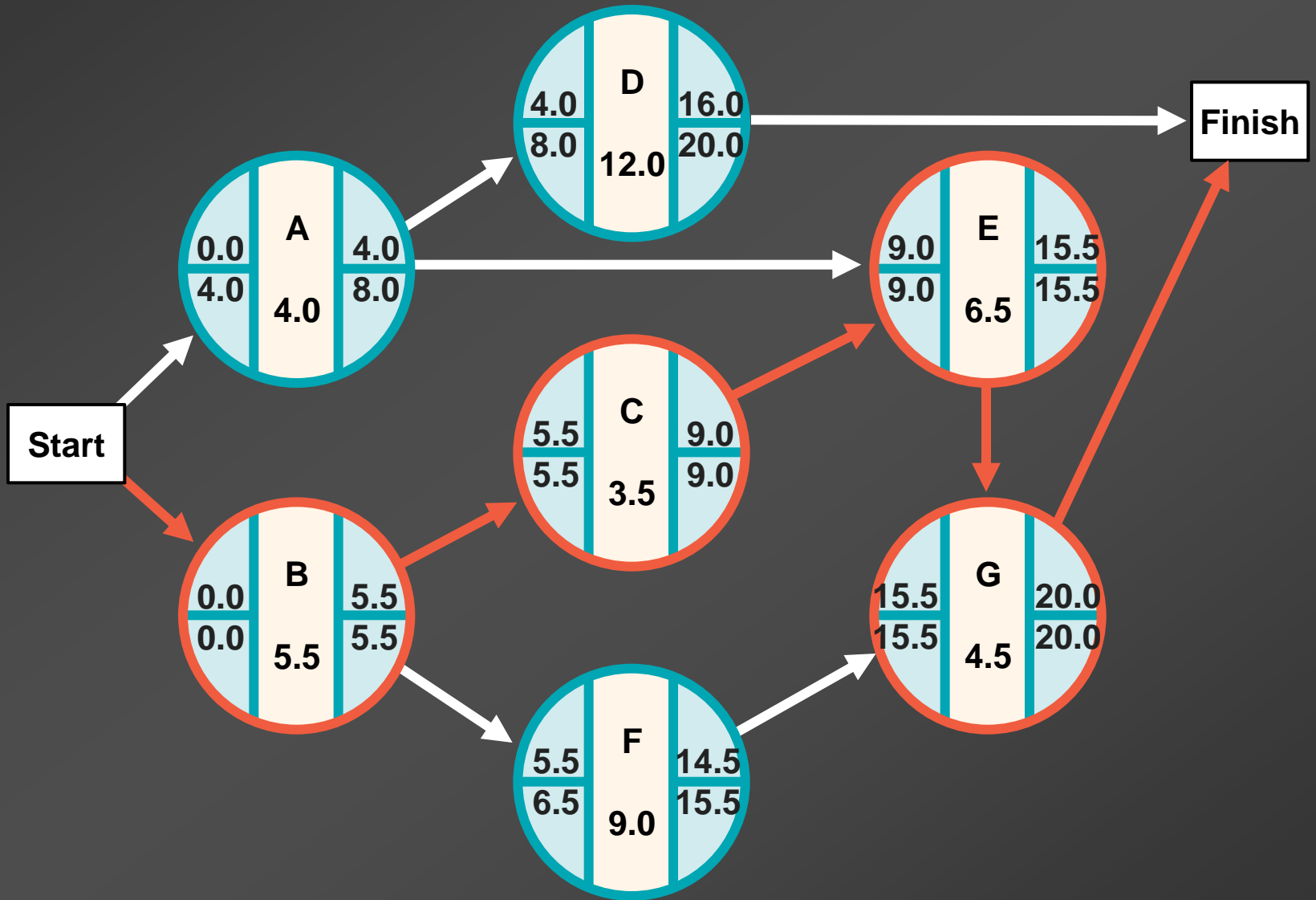

Solved Problem 2

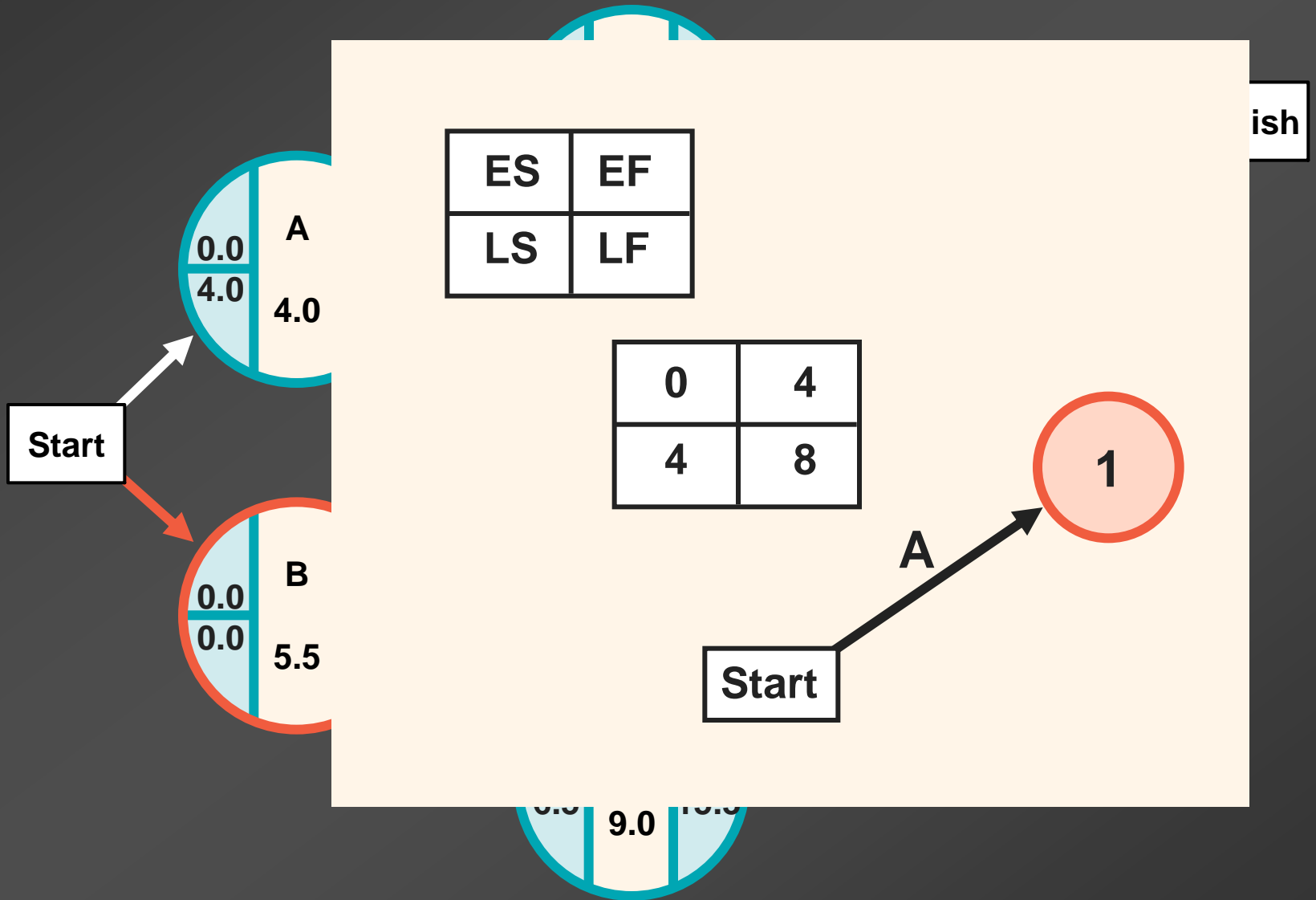

Design network decisions

- ***Complete method***
 - *Location of supply sources and markets*
 - *Location of potential facility sites*
 - *Demand forecast by market*
 - *Facility, labor and material costs by site*
 - *Transportation costs between each pair of sites*
 - *Inventory costs by site and as a function of quantity*
 - *Sale price of product in different regions*
 - *Taxes and tariffs*
 - *Desired response time and other service factors*

Cost & Demand Data related to U.S. Petroleum

<u>Inputs-Costs,Capacities, Demands</u>									
<u>Demand Region :</u>	Production and transportation cost per 1,000,000 units					Fixed	Low	Fixed	High
<u>Supply region</u>	N America	S America	Europe	Asia	Africa	cost \$	capacity	cost \$	capacity
N.America	81	92	101	130	115	6000	10	9000	20
S. America	117	77	108	98	100	4500	10	6750	20
Europe	102	105	95	119	111	6500	10	9750	20
Asia	115	125	90	59	74	4100	10	6150	20
Africa	142	100	103	105	71	4000	10	6000	20
<i>Demand</i>	12	8	14	16	7				

with

U.S. Petroleum

n = number of potential plant locations/capacity (each level of capacity will count as a separate location)

m = number of markets or demand points

D_j = annual demand from market j

K_i = potential capacity of plant i

f_i = annualized fixed cost of keeping factory i open

c_{ij} = cost of producing and shipping one unit from factory i to market j (cost includes production, inventory, transportation and tariffs)

$y_i = 1$ if plant is open, 0 otherwise

x_{ij} = quantity shipped from plant i to market j

U.S. Petroleum

$$\text{Min } \sum_{i=1}^n f_i y_i + \sum_{i=1}^n \sum_{j=1}^m c_{ij} x_{ij}$$

Under conditions to minimize the total cost

$$\sum_{i=1}^n x_{ij} = D_j \text{ for } j = 1, \dots, m$$

Demand at each regional market is satisfied

$$\sum_{j=1}^m x_{ij} \leq K_i y_i \text{ for } i = 1, \dots, n$$

No plant can supply more than its capacity (0 or 1)

$$y_i \in \{0, 1\} \text{ for } i = 1, \dots, n, x_{ij} \geq 0$$

so each plant is either open ($y_i = 1$) or closed ($y_i = 0$)

The solution identifies the plants that are to be kept open, their capacity, and the regional allocation of the demand for these plants -